

GARTENHÜTTE

MONTAGEANLEITUNG

GARDEN HUT

ASSEMBLY INSTRUCTIONS

GUARDI
ZÄUNE - TORE - BALKONE

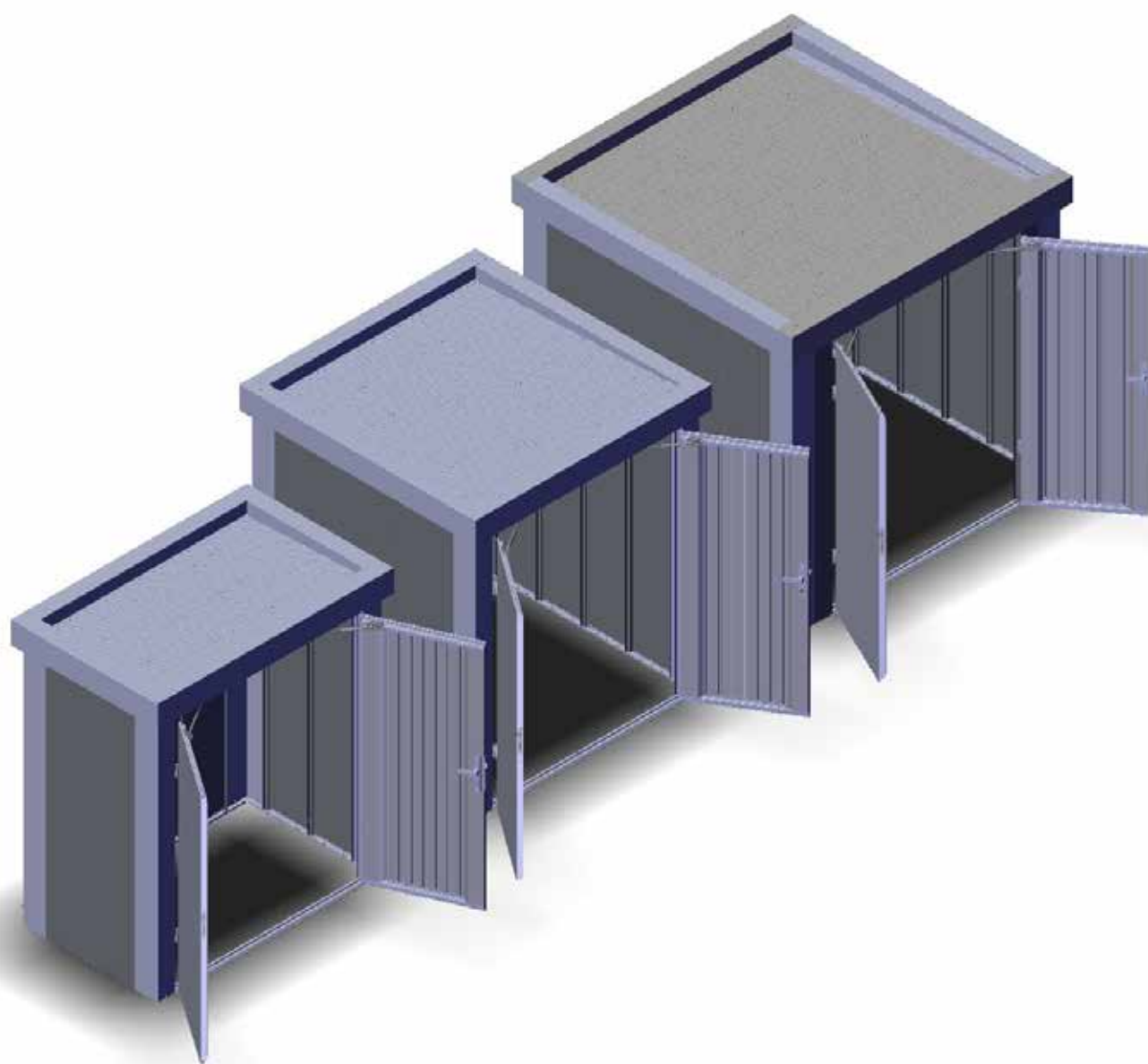

shop@guardi.at

www.guardi.at

+49 (0) 180 7000 777
+43 (0) 5 05 890

 Zeitaufwand: ca. 6 Stunden
Time required: approx. 6 hours

 2 Personen
2 persons

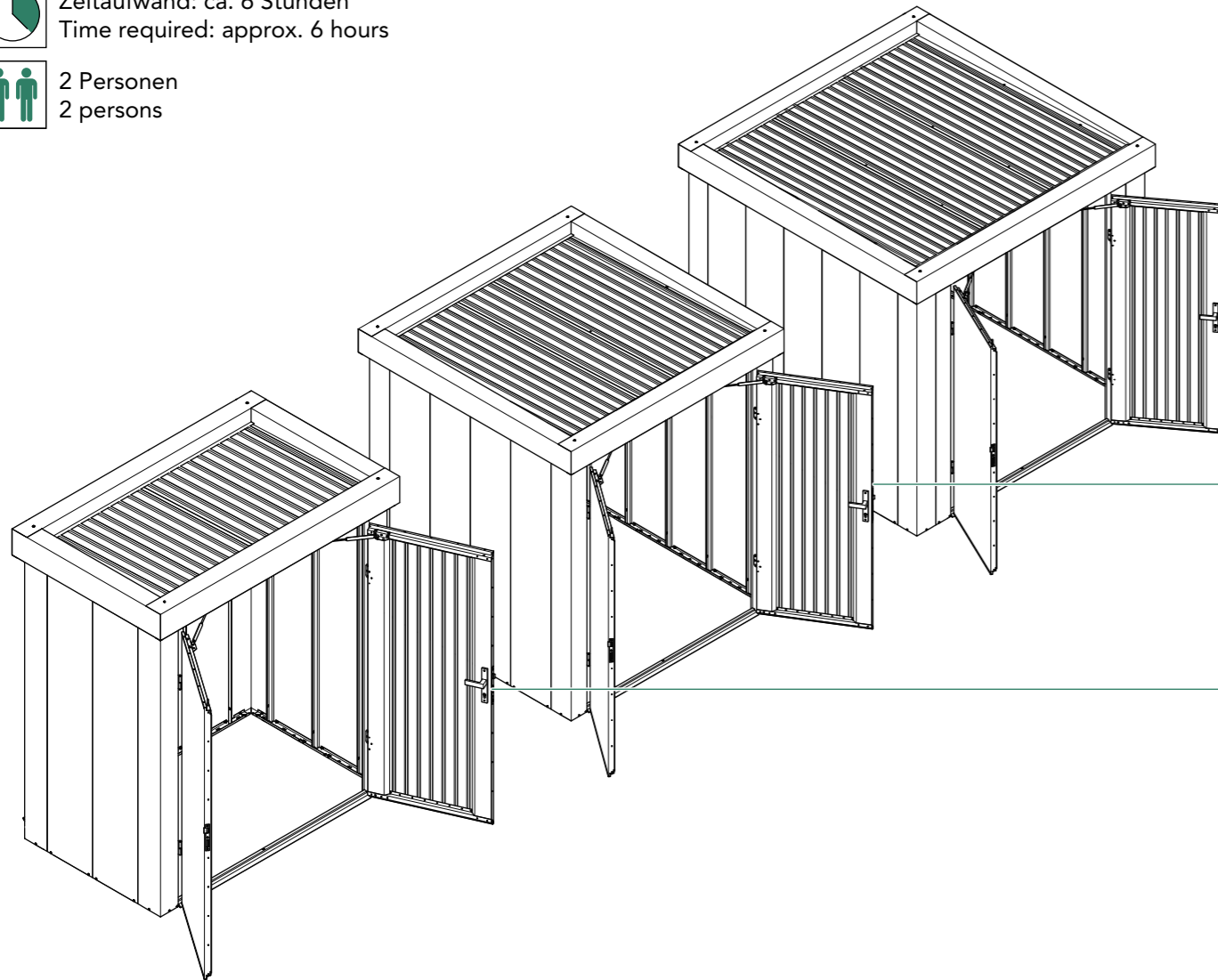

Allgemeine Informationen / General information	4/7
Werkzeug / Tools	10
Large	
Material / Materials	12
Montage mit Bodenrahmen / Assembly with floor frame	15
Montage ohne Bodenrahmen / Assembly without floor frame	16
Medium	
Material / Materials	38
Montage mit Bodenrahmen / Assembly with floor frame	41
Montage ohne Bodenrahmen / Assembly without floor frame	42
Small	
Material / Materials	62
Montage mit Bodenrahmen / Assembly with floor frame	65
Montage ohne Bodenrahmen / Assembly without floor frame	66
Zubehör / Assesories	86
Zufriedenheit und Kontakt / Feedback and contact	87

Montageanleitung lesen und aufbewahren

Diese Montageanleitung enthält wichtige Informationen zur Sicherheit und Montage der Gartenhütte.

Lesen Sie die Montageanleitung, insbesondere die Sicherheitshinweise, sorgfältig durch, bevor Sie die Gartenhütte aufbauen und verwenden.

Die Nichtbeachtung dieser Montageanleitung kann zu Verletzungen oder zu Schäden an der Gartenhütte führen. Die Montageanleitung basiert auf den in der Europäischen Union gültigen Normen und Regeln. Bewahren Sie die Montageanleitung für die weitere Nutzung auf. Wenn Sie die Gartenhütte an Dritte weitergeben, geben Sie diese Montageanleitung mit.

Technische Daten

Modell:	Guardi Gartenhütte		
Größe:	Large	Medium	Small
Produktmaße (BxTxH):	226 x 226 x 213,3 cm	190 x 190 x 213,3 cm	190 x 118 x 213,3 cm
Innenmaße (BxT):	207,6 x 207,6 cm	171,6 x 171,6 cm	171,6 x 99,6 cm
Türlichte Breite:	148,7 cm	148,7 cm	148,7 cm
Stauraumvolumen:	8,62 m ³	5,89 m ³	3,79 m ³

Vorsicht

Verletzungsgefahr
Scharfkantige oder spitze Bauteile können zu Handverletzungen führen.
Verwenden Sie bei der Montage Arbeitshandschuhe.

Hinweise

Für eine sichere Montage sind 2 Personen erforderlich.
Um Kratzer an der Gartenhütte zu vermeiden, verwenden Sie die Kartonverpackung als Unterlage.
Öffnen Sie die Kartonverpackung nicht mit einem scharfen Gegenstand wie Messer o.ä.
Für eine sichere Montage die Gartenhütte nicht bei Wind aufstellen.
Platzbedarf: Basis der Gartenhütte plus mind. 30 cm auf jeder Seite.
Das Dach zur Schneeräumung nicht betreten. Benutzen Sie Leiter und Besen.

Symbole in der Anleitung



Arbeitsschritt mithilfe einer zweiten Person ausführen.



Gezeigten Bauteil beim Einbau mithilfe einer Wasserwaage ausrichten.



Schutzfolie der Bleche abziehen.



Schraube/Mutter vorerst nur handfest anziehen.



Schraube/Mutter fest nachziehen.



Weitere Informationen auf der angeführten Seite der Montageanleitung.

Montage

1. Lieferumfang auf Vollständigkeit und Beschädigung prüfen.
2. Schutzfolie der Bleche erst bei den entsprechenden Arbeitsschritten abziehen.
3. Schrauben pro Arbeitsschritt locker fixieren.
4. Bleche positionieren.
5. Schrauben mit Schraubendreher fest anziehen.
6. Für eine Bodenverankerung sorgen, damit die Gartenhütte sturmsicher ist.

Bodenbefestigung

Die ideale Befestigung im Boden variiert je nach Untergrund. Das Befestigungsmaterial ist nicht im Lieferumfang enthalten.

Bodenfeuchtigkeit

Beim Aufbau auf einer Wiese oder auf Schotter eine Dampfsperre bzw. Kondensatfolie unterlegen, um zu verhindern, dass Bodenfeuchtigkeit in die Gartenhütte aufsteigt.

Regensammelsystem

Alternativ zu den mitgelieferten Fallrohren kann ein eigenes Regensammelsystem mit G1/2" Anschluss montiert werden.

Türen einrichten

Falls die beiden Türflügel nicht fluchten, die obere Blende entfernen und die Gartenhütte korrekt ausrichten. Die Blende wieder ordnungsgemäß einsetzen, um eine Deformierung zu vermeiden.

Pflege

- Keine aggressiven Chemikalien wie z.B. Chlor oder Streusalz lagern.
- Keine scheuernden Reinigungsmittel verwenden.
- Verschmutzungen mit Wasser und Seife entfernen.

Jährliche Wartung

- Türschloss der Gartenhütte mit geeignetem Schmierstoff ölen.
- Tür-Scharniere ölen.
- Dachrinne reinigen und von Schmutz, Moos und Flechten befreien. Dazu das hintere Blech entfernen.

Einsatz

Aus Sicherheitsgründen Tür der Gartenhütte immer verriegeln.
Berücksichtigen, dass sich im Sommer hohe Temperaturen in der Gartenhütte entwickeln können.

Read and keep the assembly instructions

These assembly instructions contain important information about the safety and assembly of the garden hut.

Read the assembly instructions carefully, especially the safety information, before assembling and using the garden hut.

Failure to follow these assembly instructions may result in injury or damage to the garden hut. The assembly instructions are based on the standards and rules applicable in the European Union. Keep the assembly instructions for further use. If you pass the garden hut on to a third party, please include these assembly instructions.

Technical data

Modell	Guardi Garden hut		
Size:	Large	Medium	Small
Dimensions (WxDxH):	226 x 226 x 213,3 cm	190 x 190 x 213,3 cm	190 x 118 x 213,3 cm
Internal dimensions (WxD):	207,6 x 207,6 cm	171,6 x 171,6 cm	171,6 x 99,6 cm
Door clearance width:	148,7 cm	148,7 cm	148,7 cm
Storage room volume:	8,62 m ³	5,89 m ³	3,79 m ³







Caution

Risk of injury
Sharp-edged or pointed components can cause hand injuries.
Use work gloves during assembly.

Notice

2 people are required for safe assembly.
To avoid scratching the waste container, use the cardboard packaging as a base.
Do not open the cardboard packaging with sharp objects such as knives.
Do not set up the garden hut in windy conditions to ensure safe assembly.
Space requirements: Base of the garden shed plus at least 30 cm on each side.
Do not climb onto the roof to remove snow. Use a ladder and broom.

Symbols in the instructions

-  Carry out this working step with assistance from another person.
-  Align the component shown using a spirit level during installation.
-  Pull protective film off the sheets.
-  Initially, only tighten the screw/nut hand-tight.
-  Tighten the screw/nut firmly.
-  You can find more information on the listed page of the assembly instructions.
S. 6 / P. 9

Assembly instructions

1. Check the scope of delivery for completeness.
2. Pull protective film off the sheets during the corresponding work steps.
3. Loosely fix the screws for each work step.
4. Position the plates.
5. Tighten the screws firmly with the screwdriver.
6. Ensure that floor anchoring is used to prevent the garden hut blowing away in windy weather.

Floor anchoring

The ideal method of anchoring the product in the ground varies depending on the subsurface. Anchoring material is not included in the scope of delivery.

Ground moisture

When assembling on a lawn or gravel, lay down a moisture barrier or condensation film to prevent ground moisture from getting into the garden shed.

Rain collection system

A rain collection system with G1/2" connection can be assembled as an alternative to the supplied drain pipes.

Setting up doors

If the two door leaves are not aligned, remove the upper panel and correctly align the garden shed. Reinsert the panel properly to prevent deformation.

Care

- Do not store aggressive substances such as chlorine or road salt.
- Do not use abrasive cleaning agents.
- Remove stains with water and soap.

Annual maintenance

- Oil the garden shed lock with a suitable lubricant.
- Oil the door hinges.
- Clean the roof gutters and remove dirt, moss and lichen. Remove the rear panel to do so.

Use

For reasons of safety, always lock the door of the garden hut. Please take into consideration that high temperatures may develop inside the garden hut during the summer months.

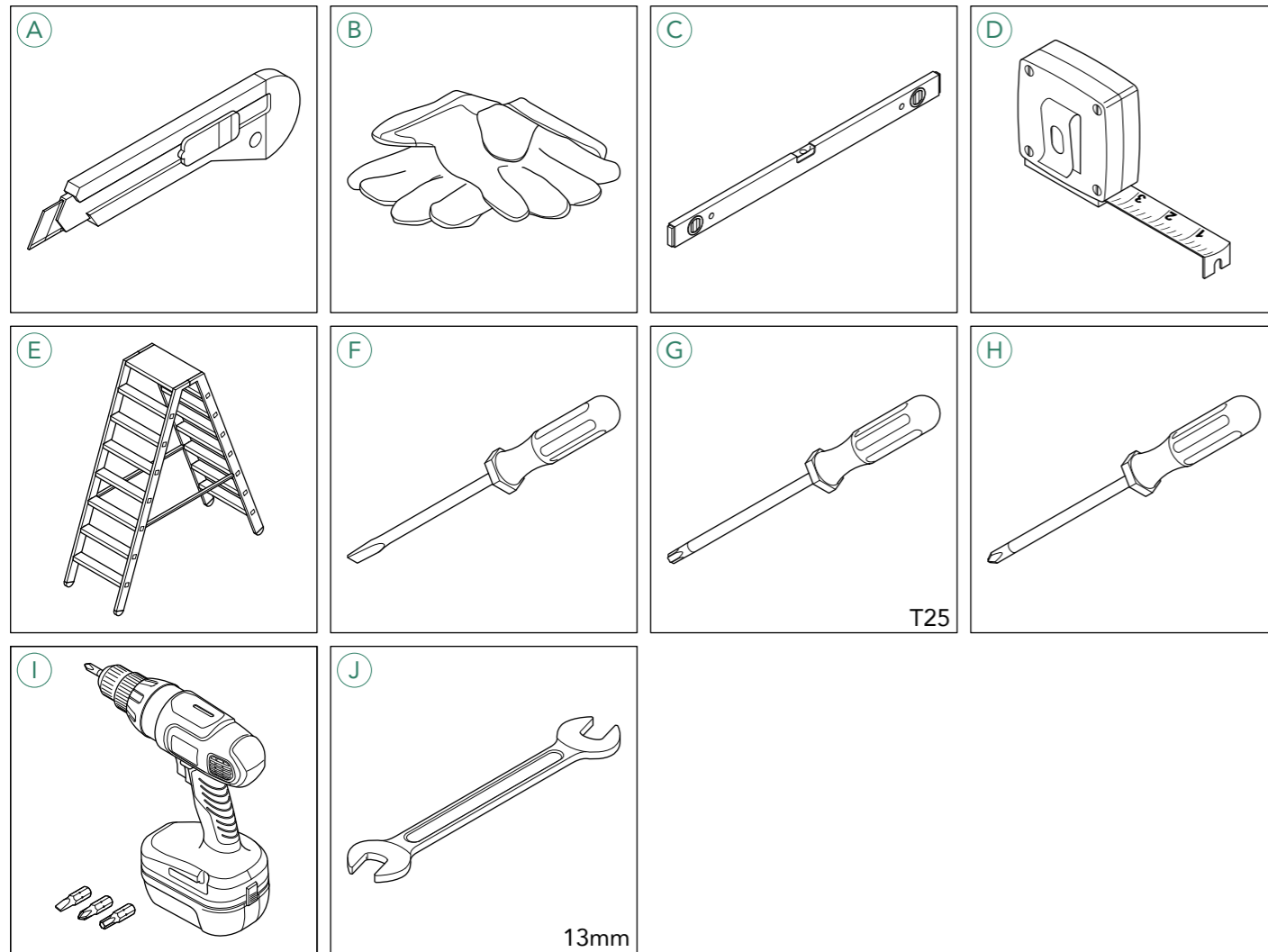

Werkzeug / Tools

- A Messer / Utility knife
- B Arbeitshandschuhe / Work gloves
- C Wasserwaage / Spirit level
- D Maßband / Measuring tape
- E Leiter / Ladder
- F Schraubendreher (Schlitz) / Slot screwdriver
- G Schraubendreher (Torx) / Torx screwdriver
- H Schraubendreher (Kreuz) / Crosshead screwdriver
- I Akkuschauber (optional) / Electric drill (optional)
- J Schraubenschlüssel / Wrench

Hinweise

Für eine zeitsparende Montage einen Akkuschauber auf schwacher Drehmomentstufe verwenden. Festigkeit mit dem mitgelieferten Schlüssel manuell kontrollieren. Das Dach während der Montage nicht betreten und bei Bedarf eine Leiter benutzen.

Notices

For faster assembly, use an electric screwdriver set to a low speed. Manually check the strength with the supplied wrench. Do not climb onto the roof during assembly, use a ladder if needed.

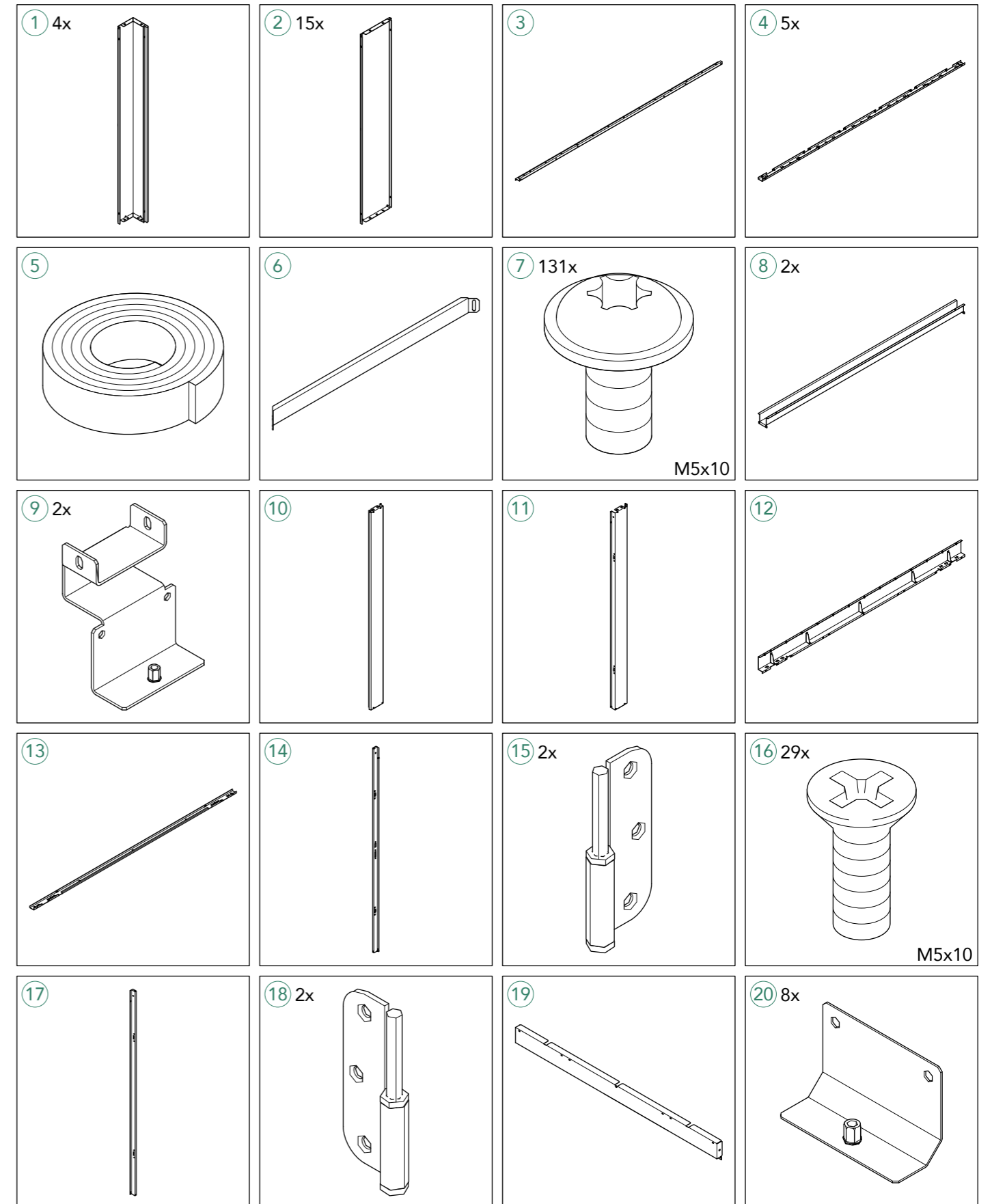
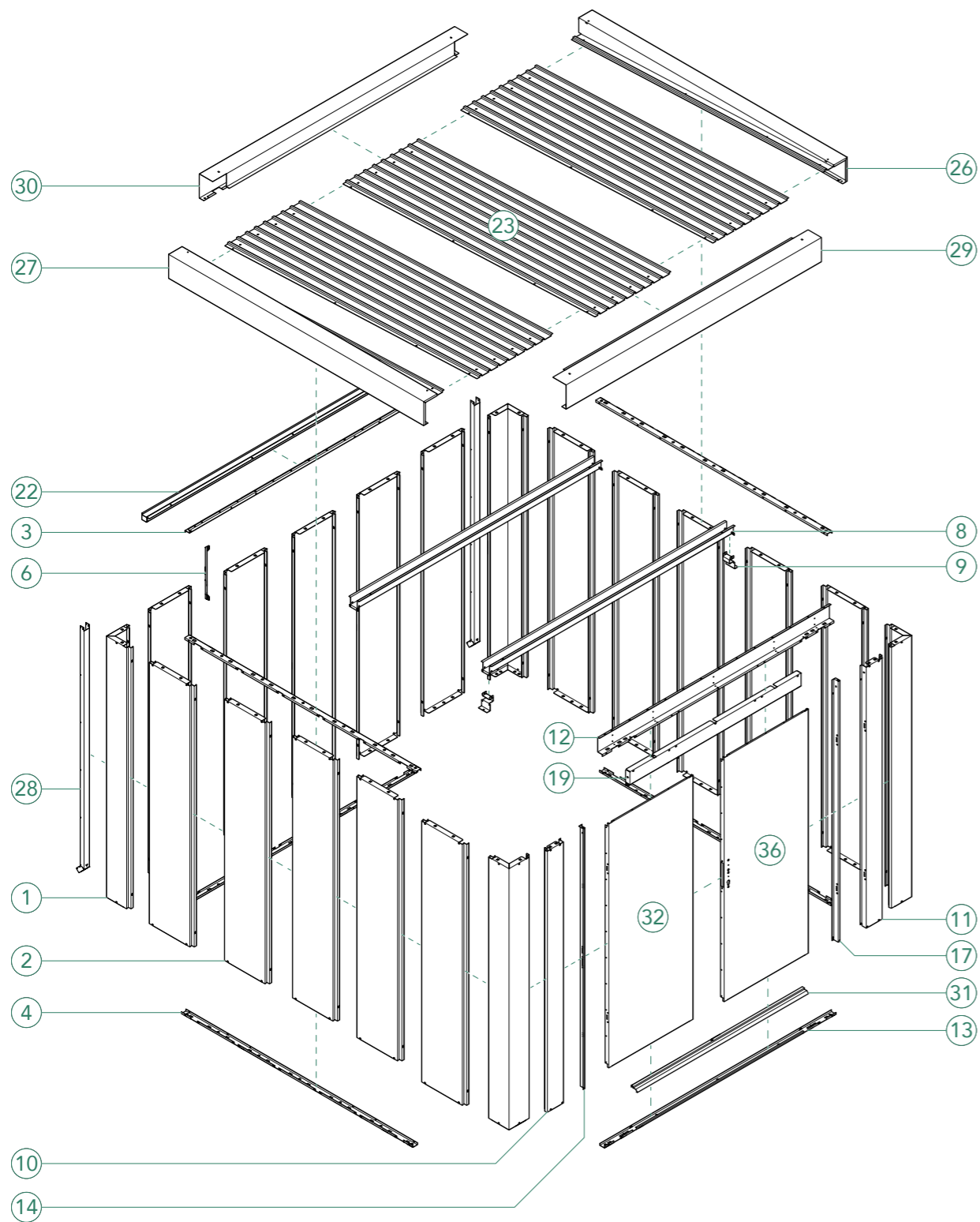

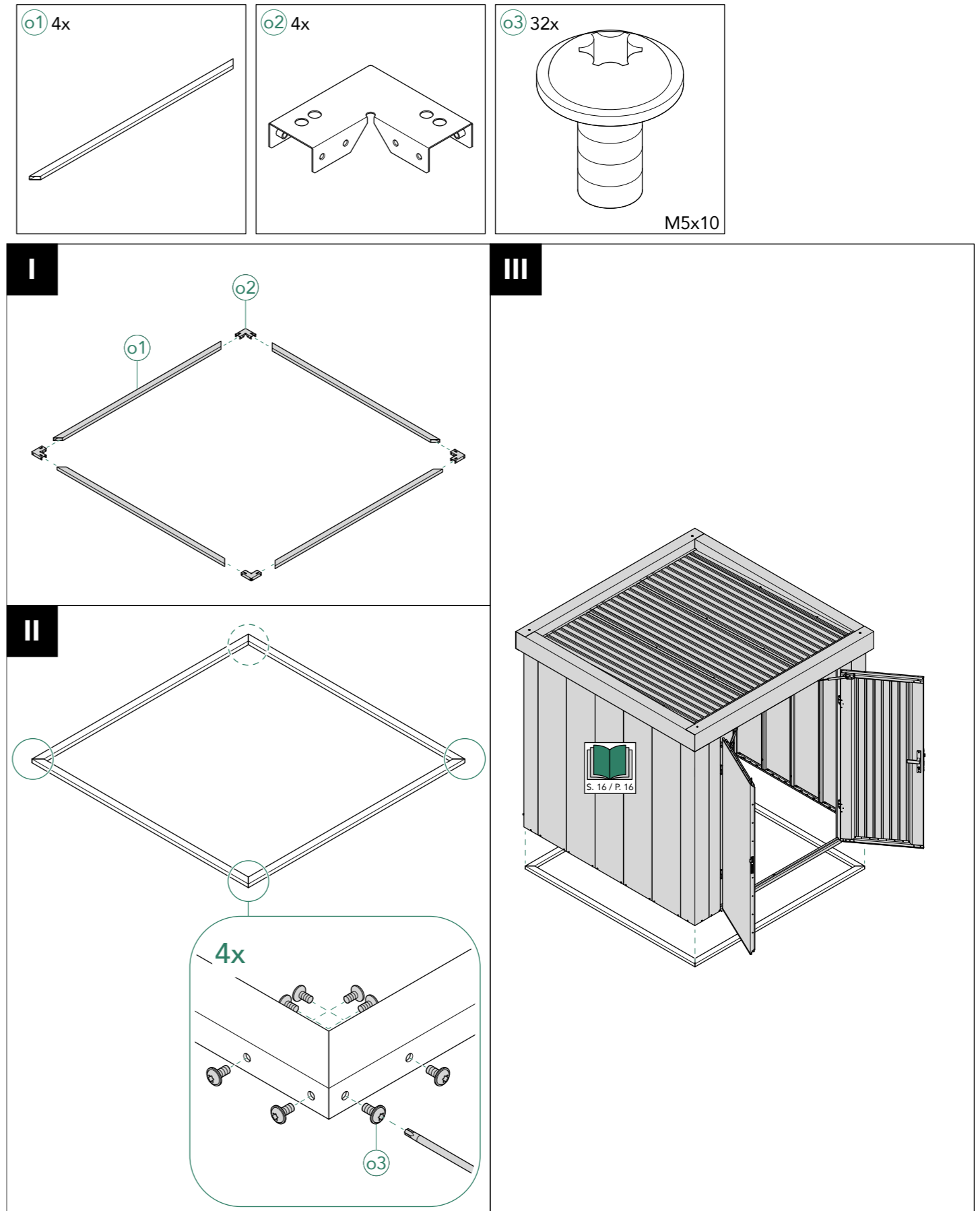
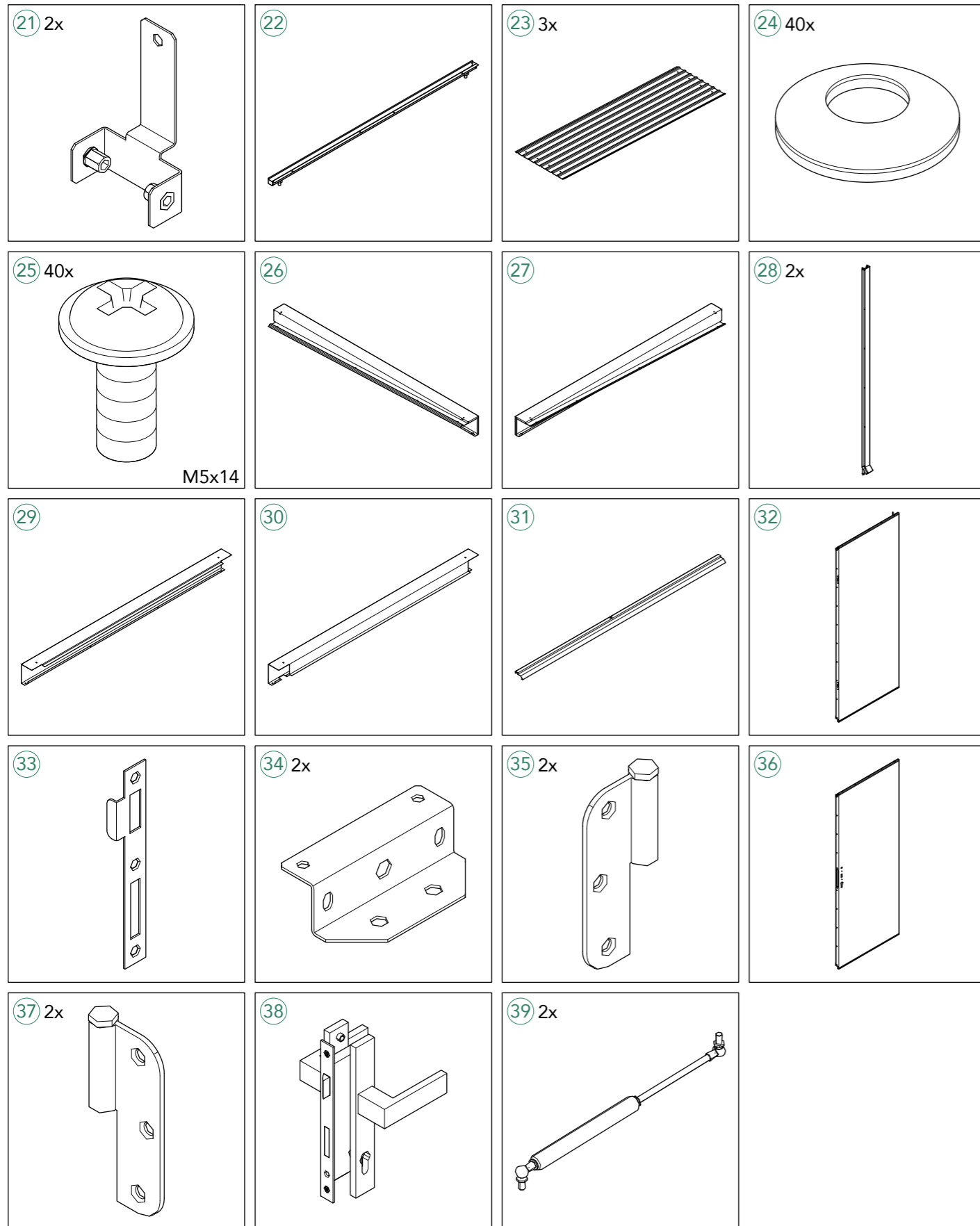

01

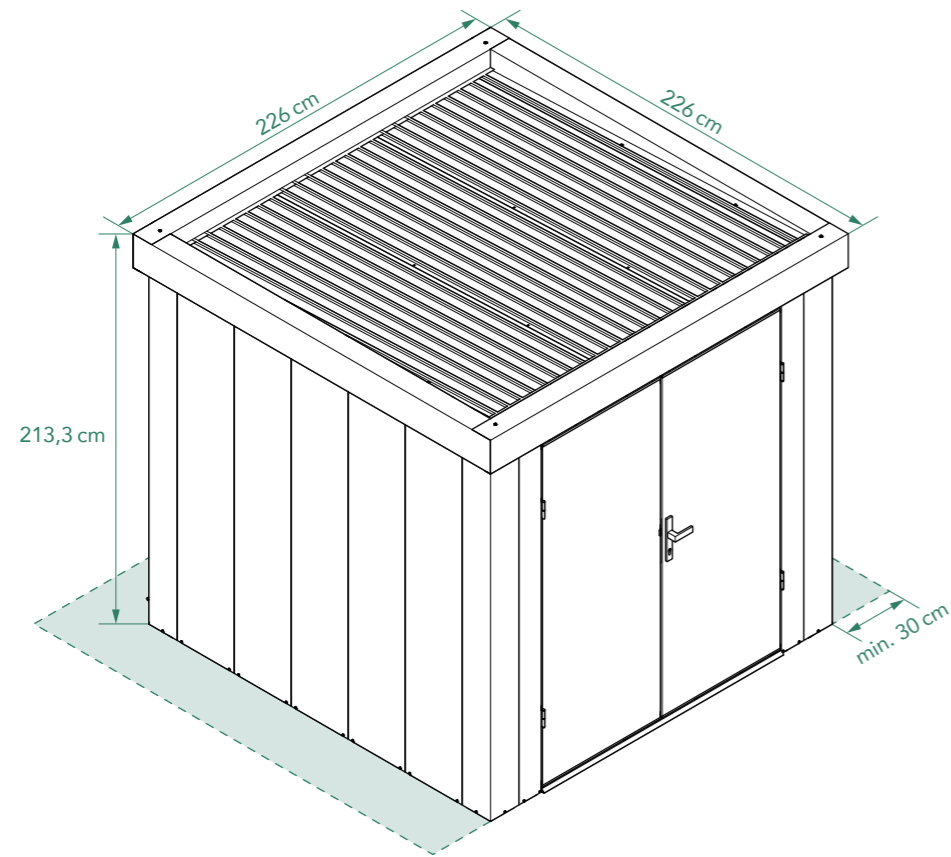

02

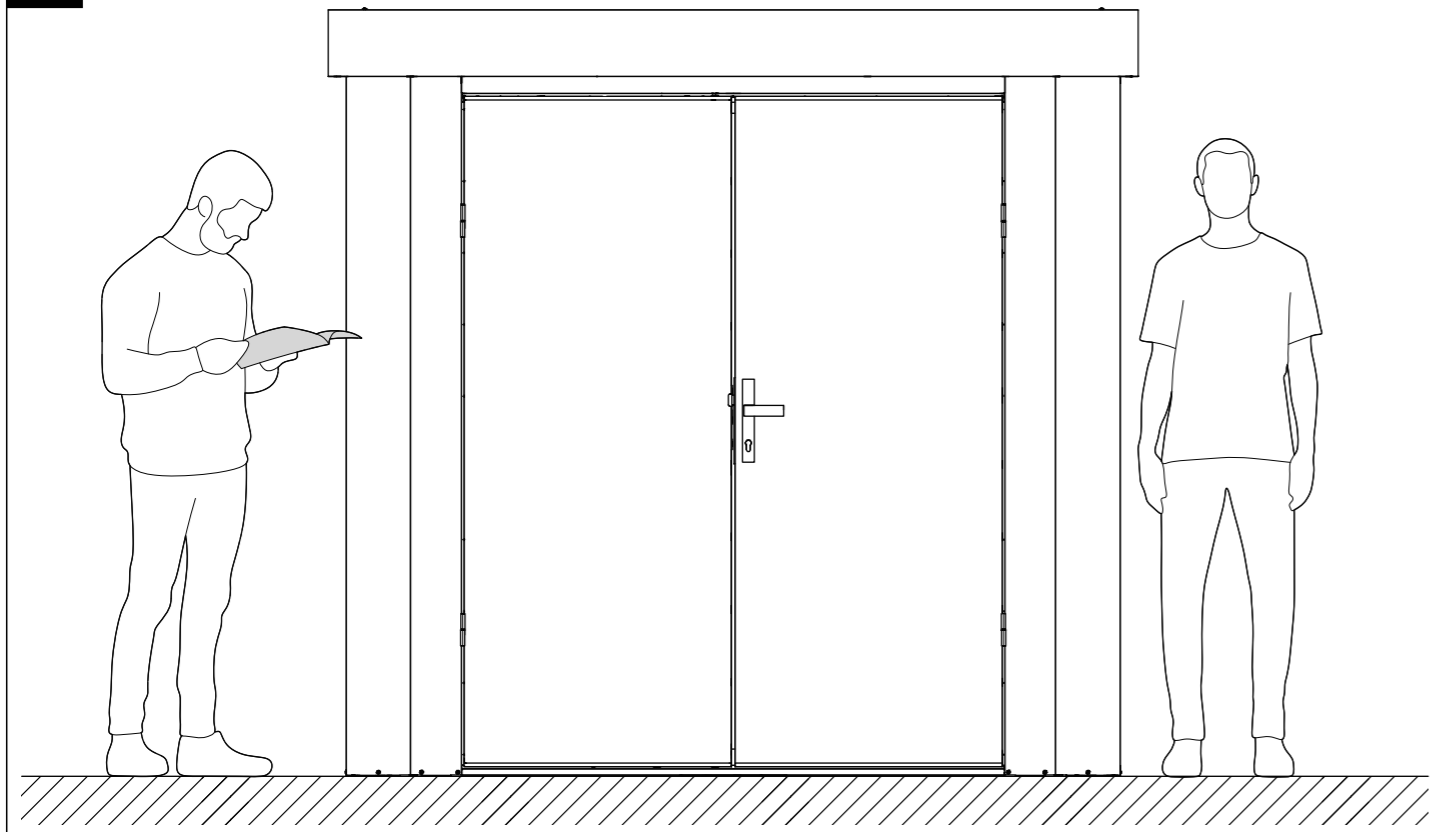

03

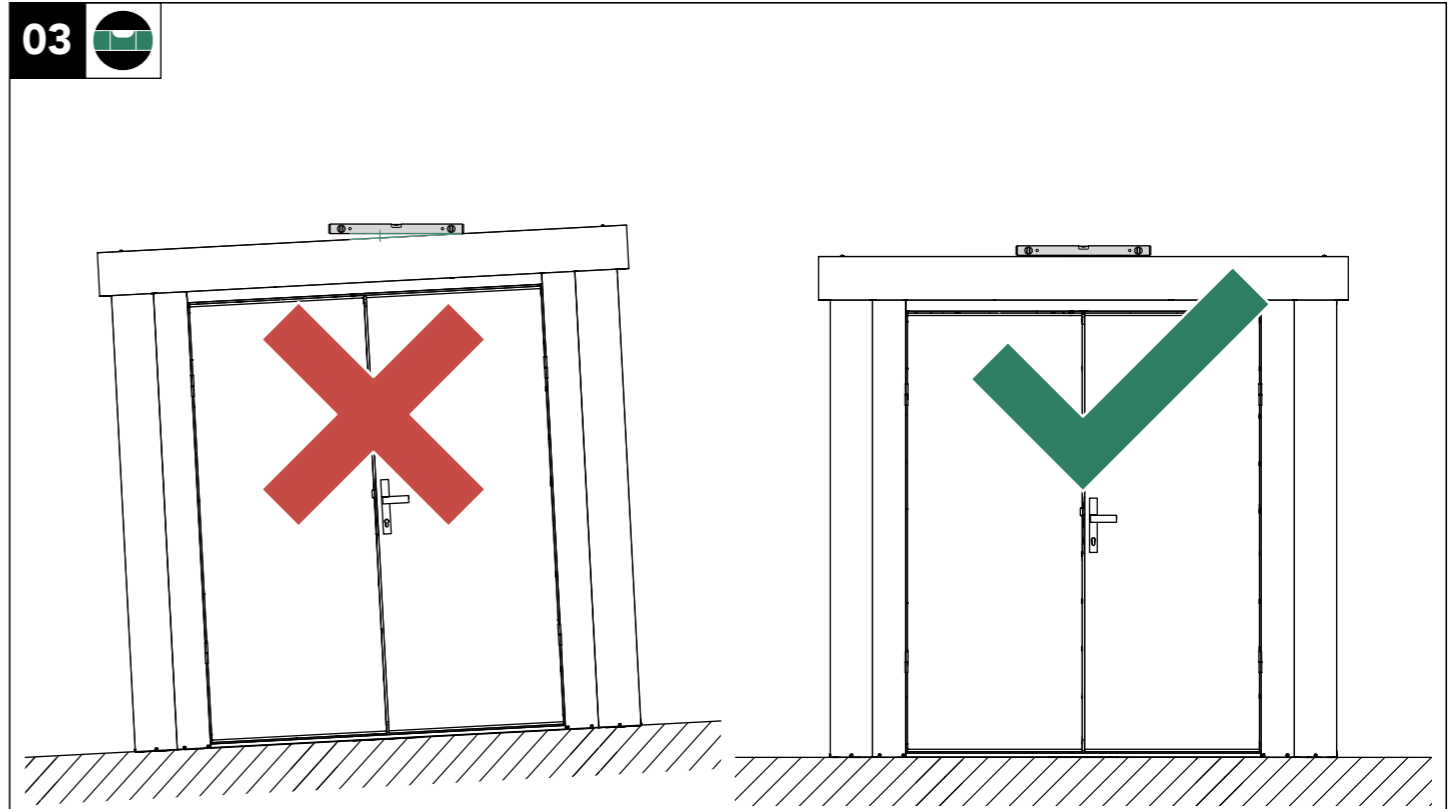

04

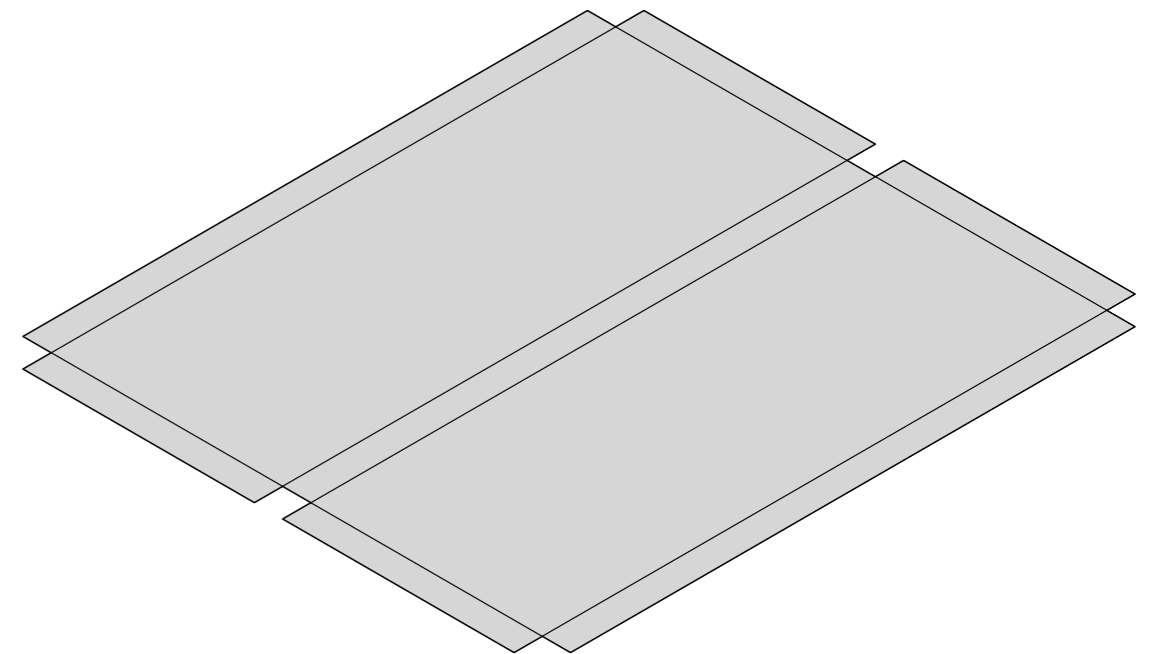

DE Kartonverpackung unterlegen
EN Underlay cardboard packaging

05

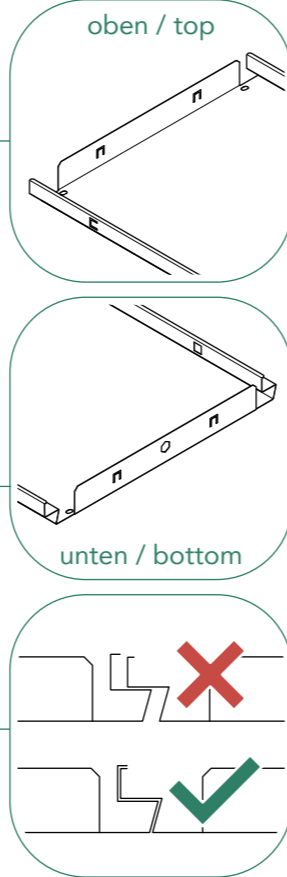
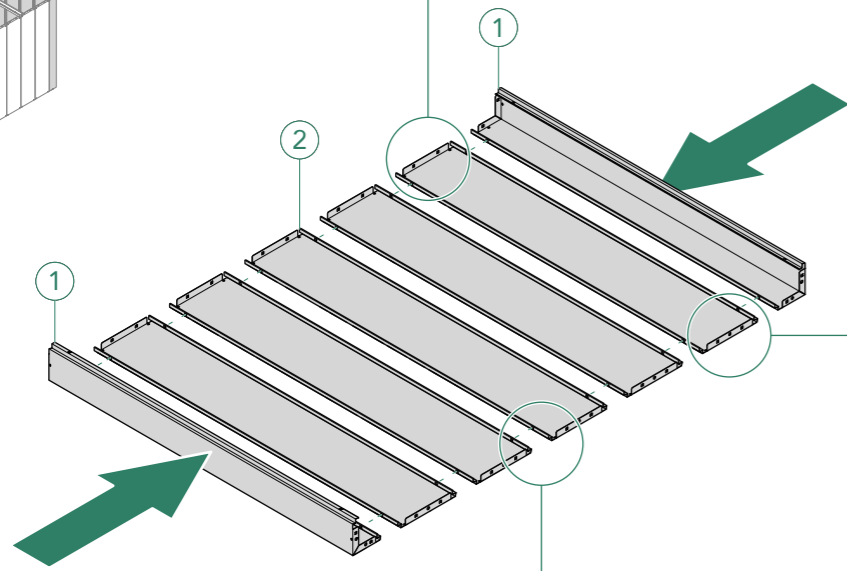
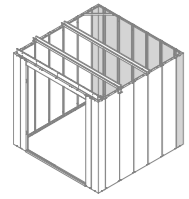

06

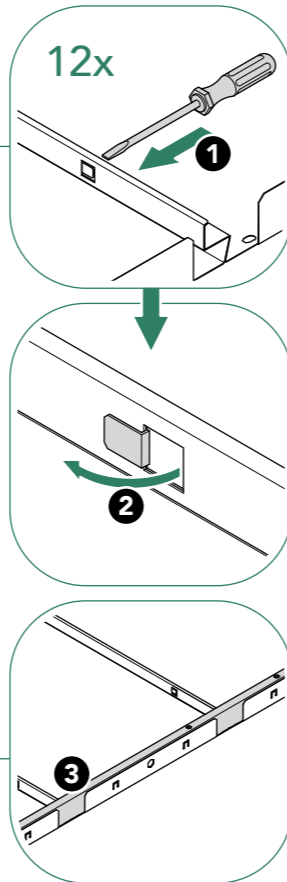
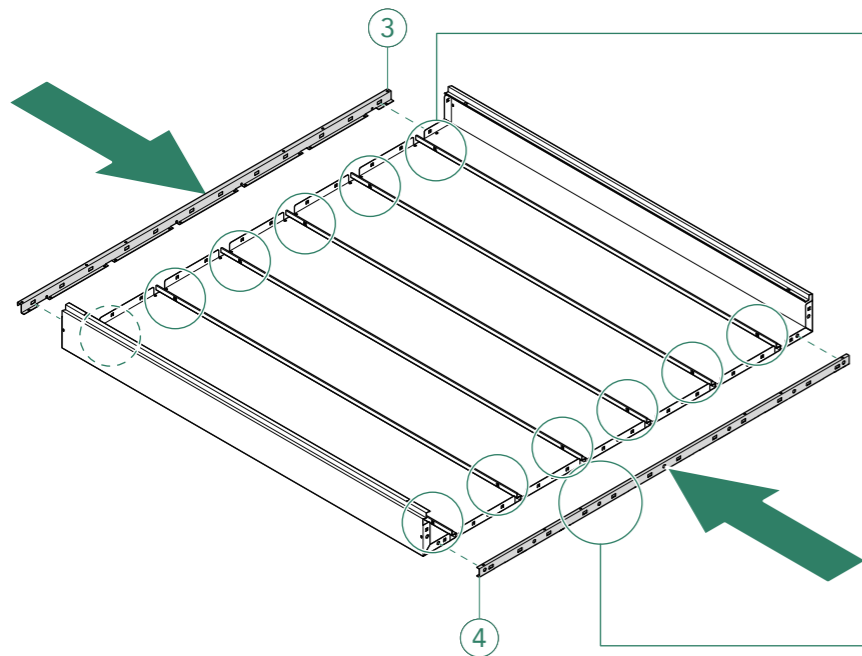

07

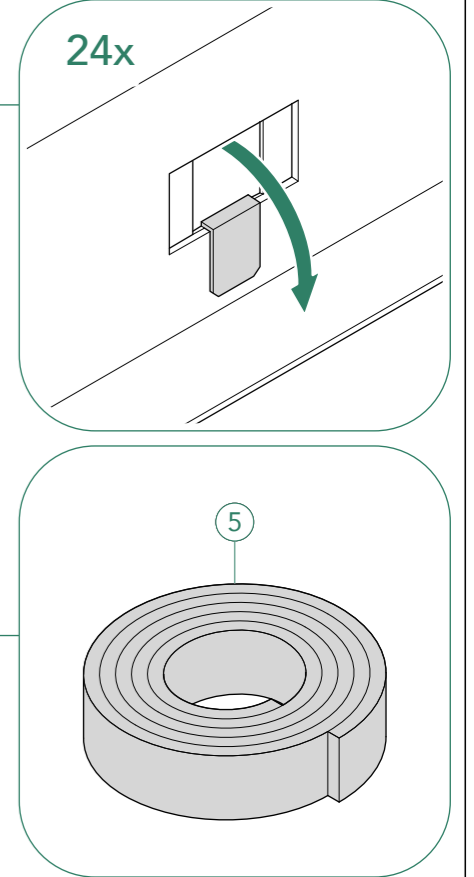
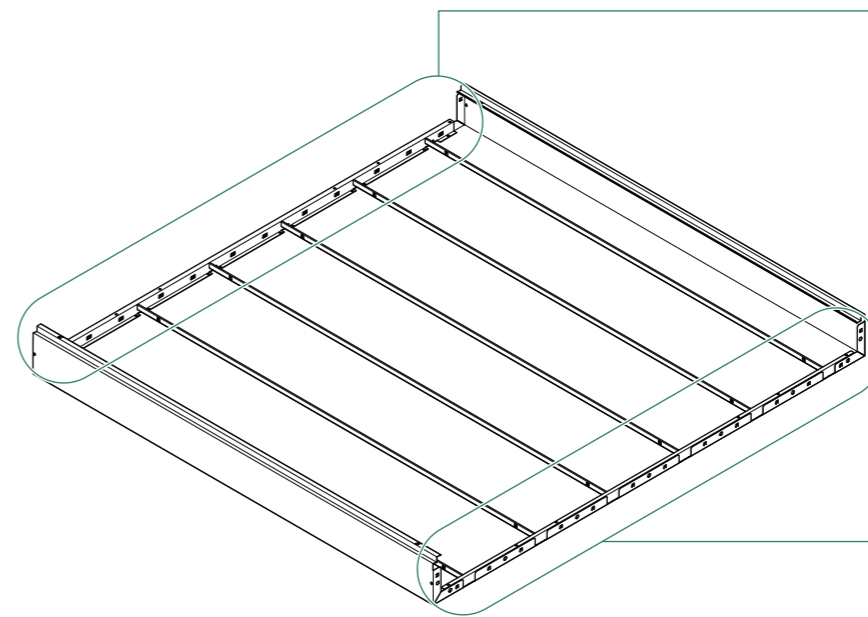

08

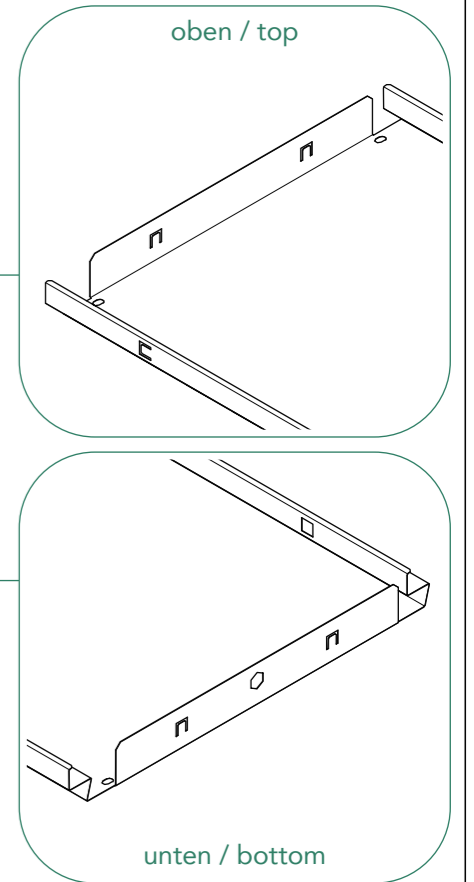
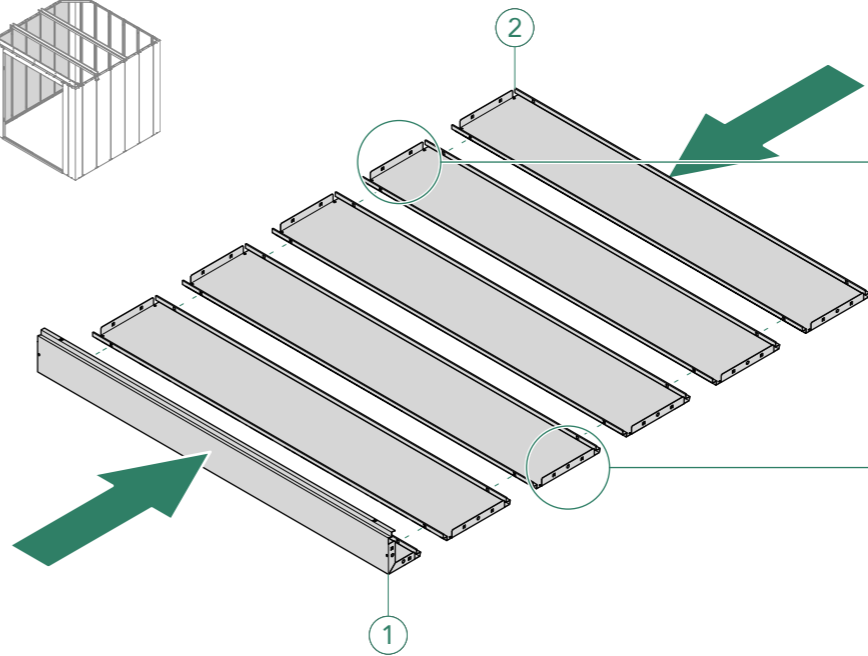
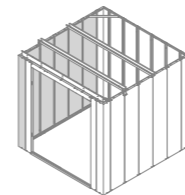

09

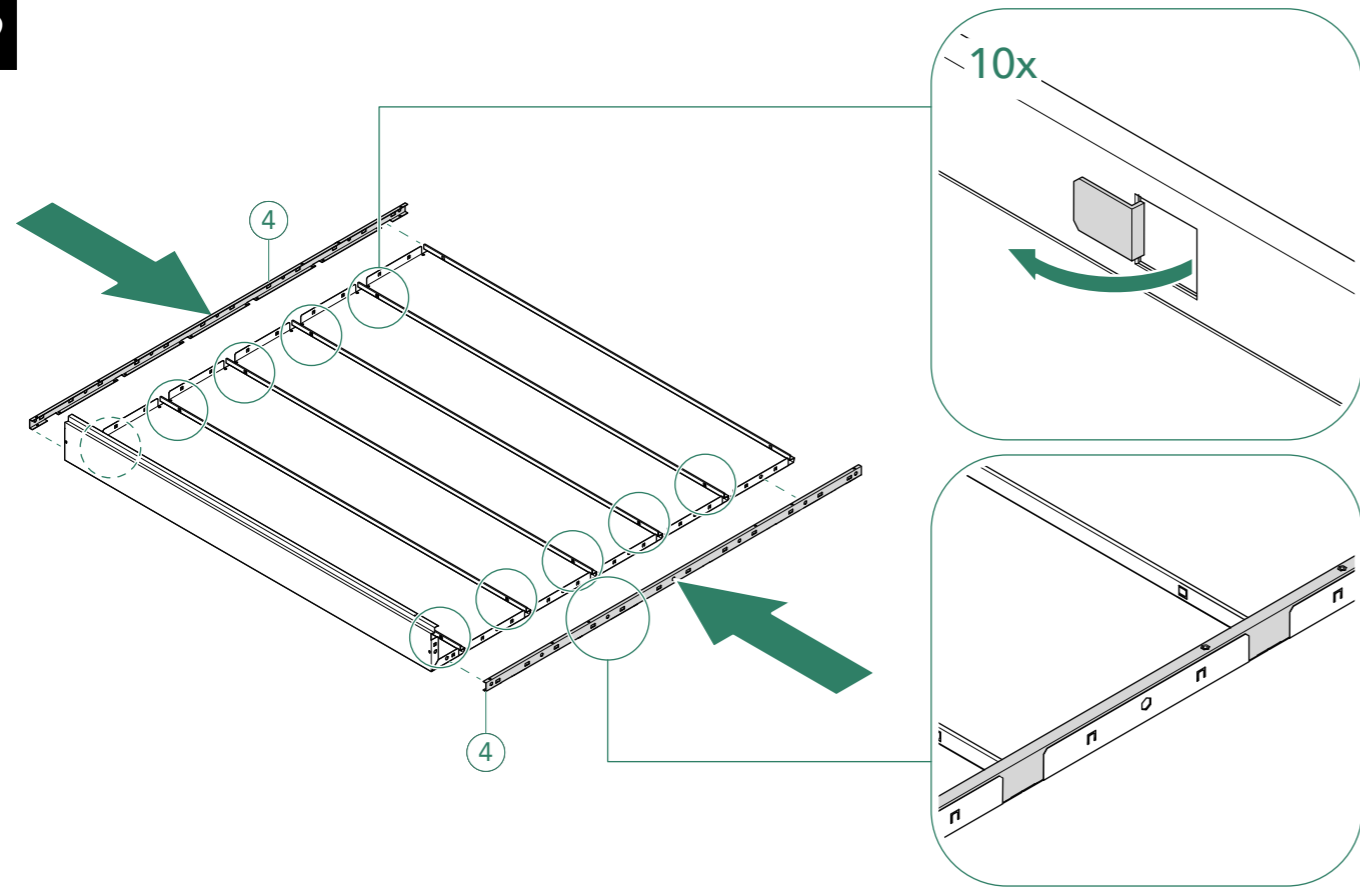

10

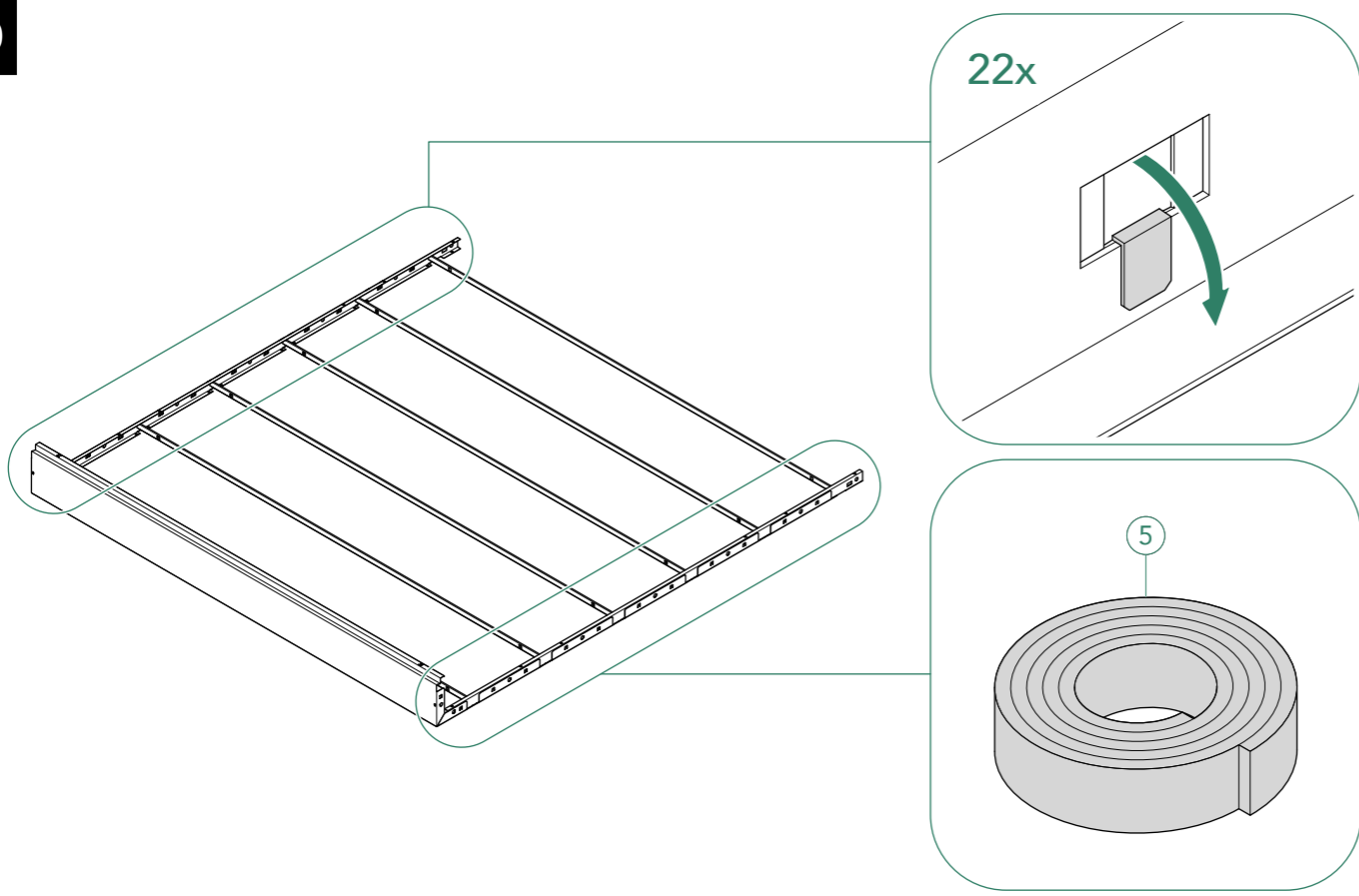

11

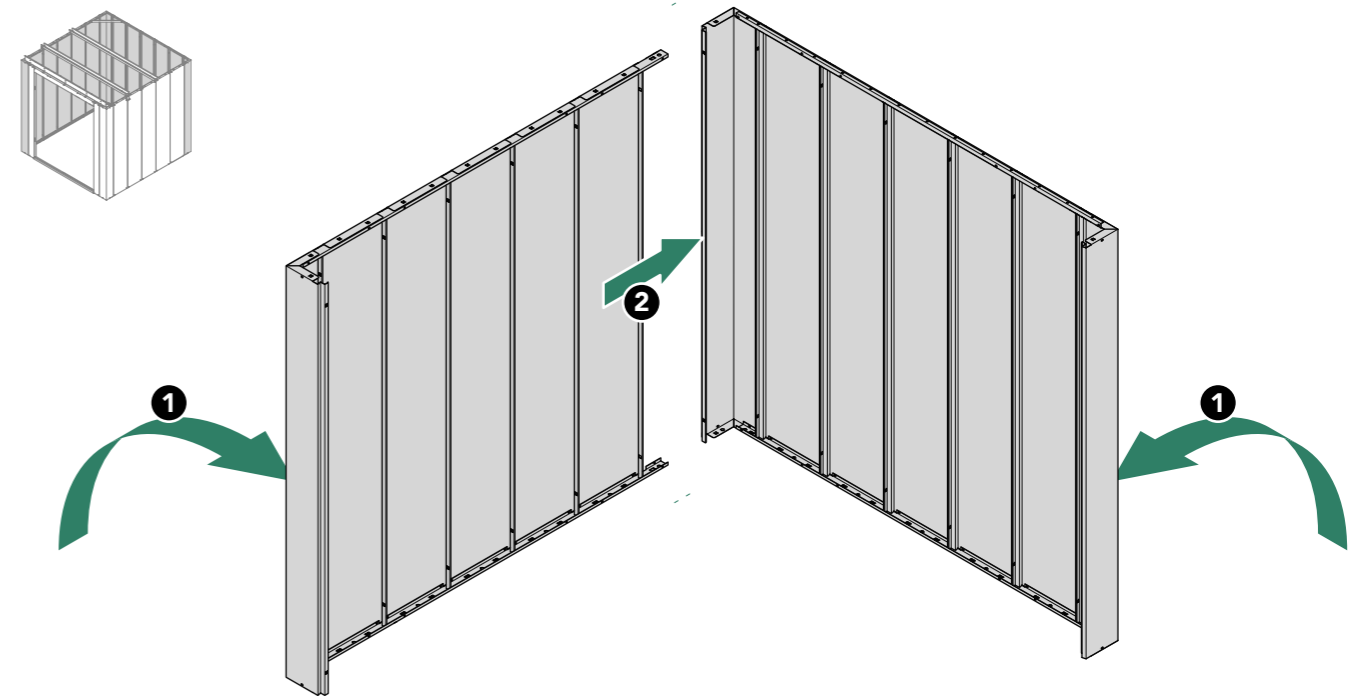

12

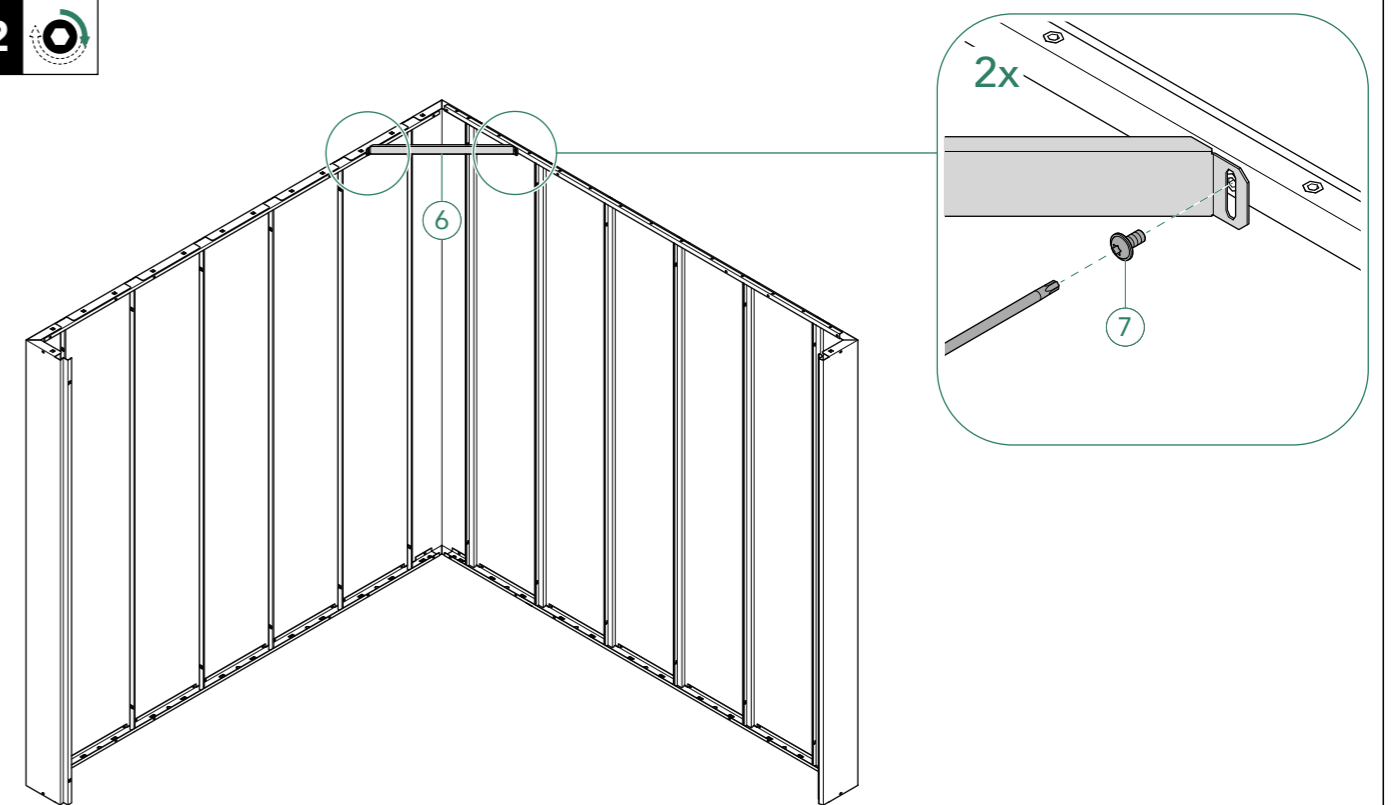

13

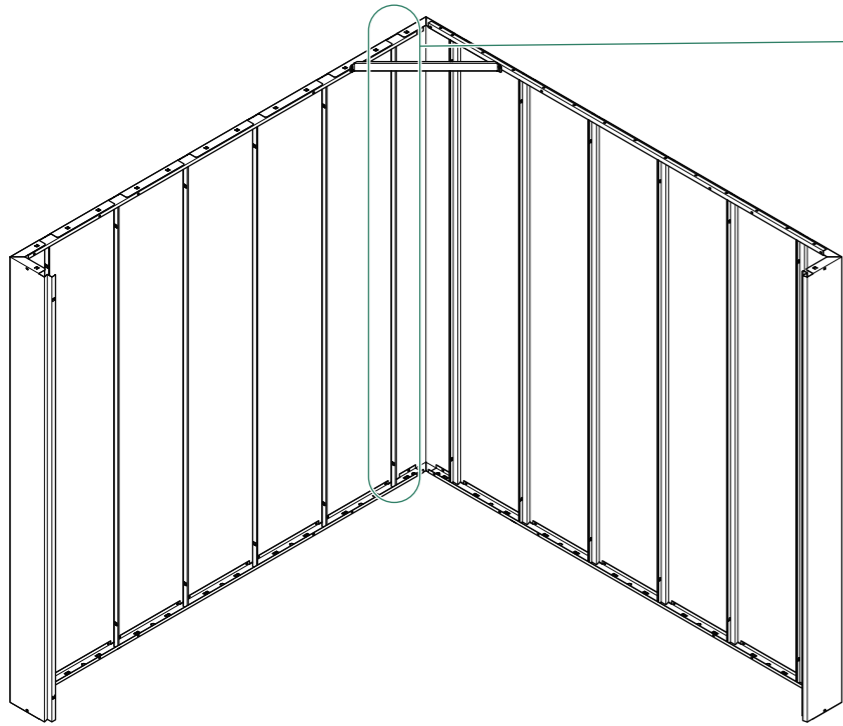

4x

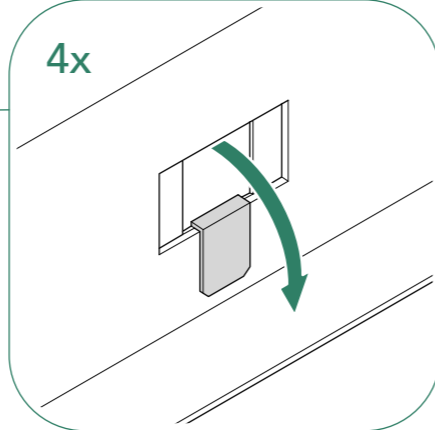

2x

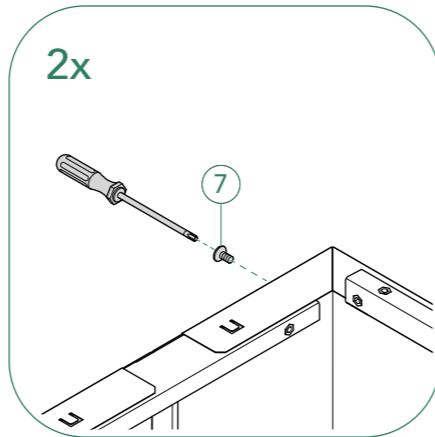

14

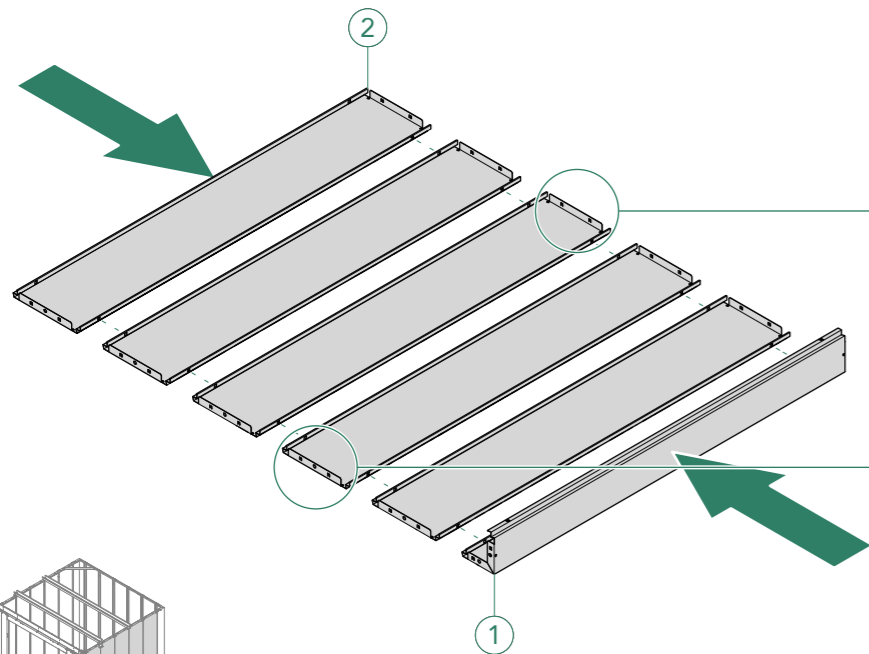

oben / top

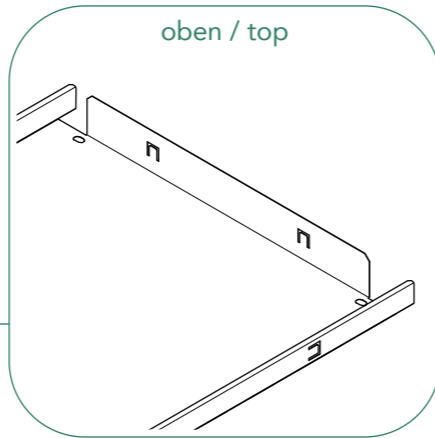

unten / bottom

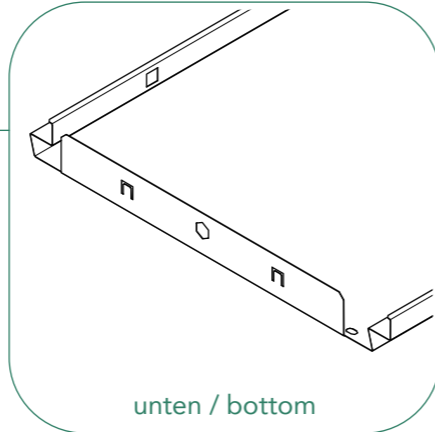

15

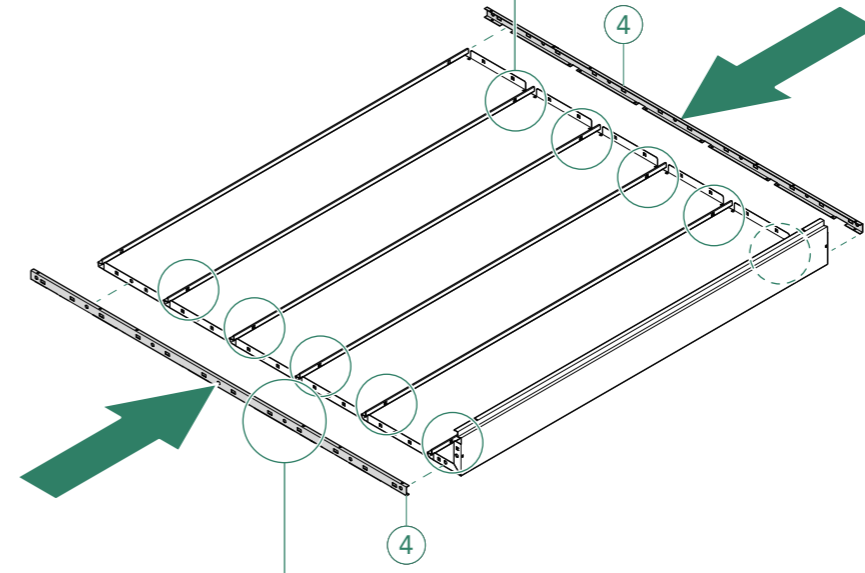

10x

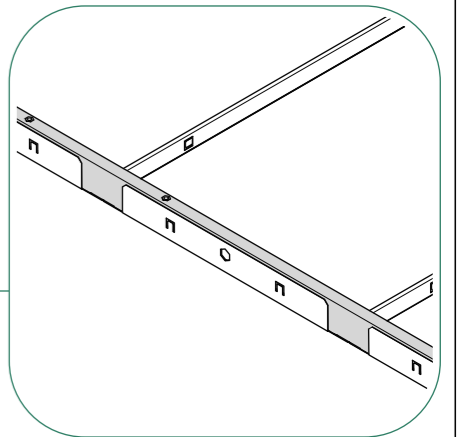
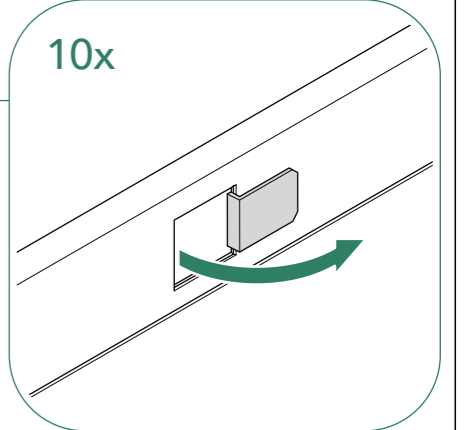

16

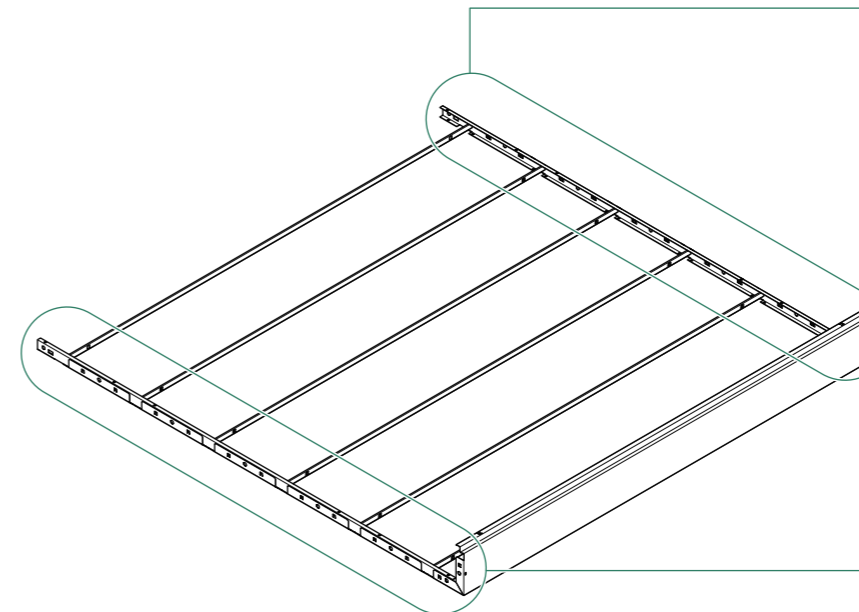

22x

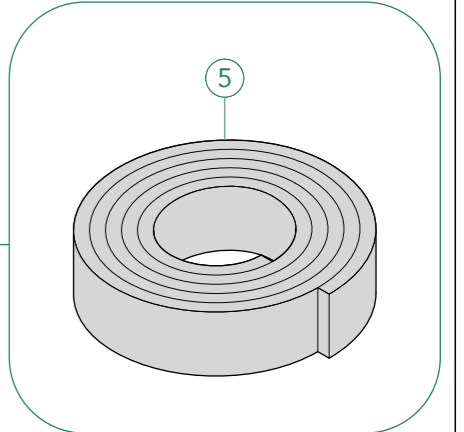
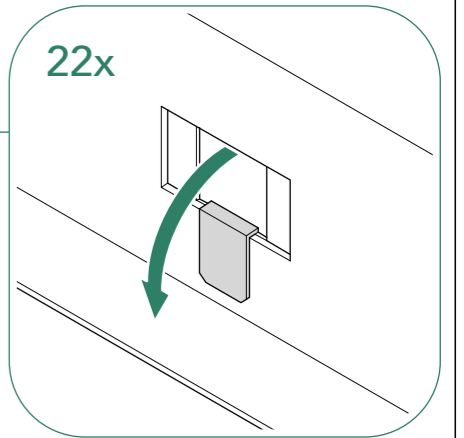

17

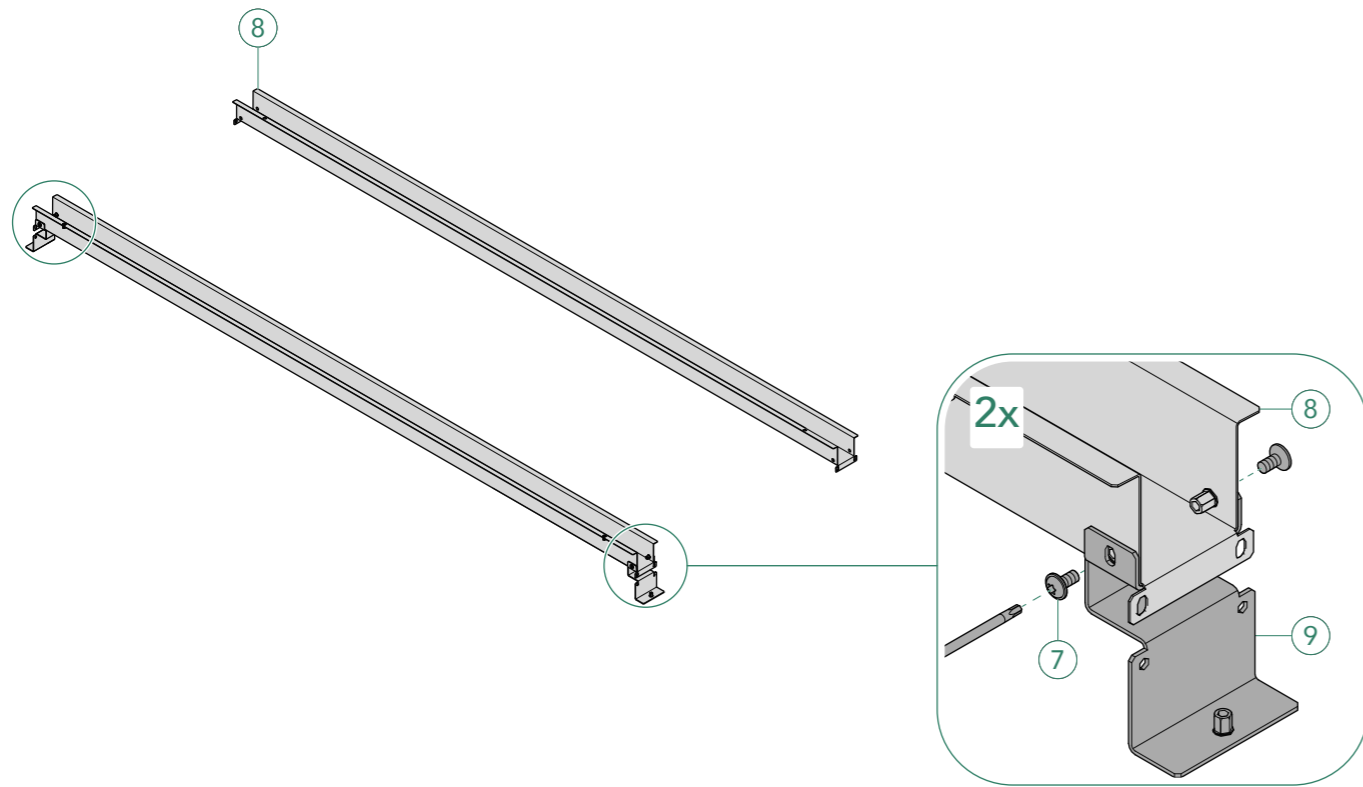

18

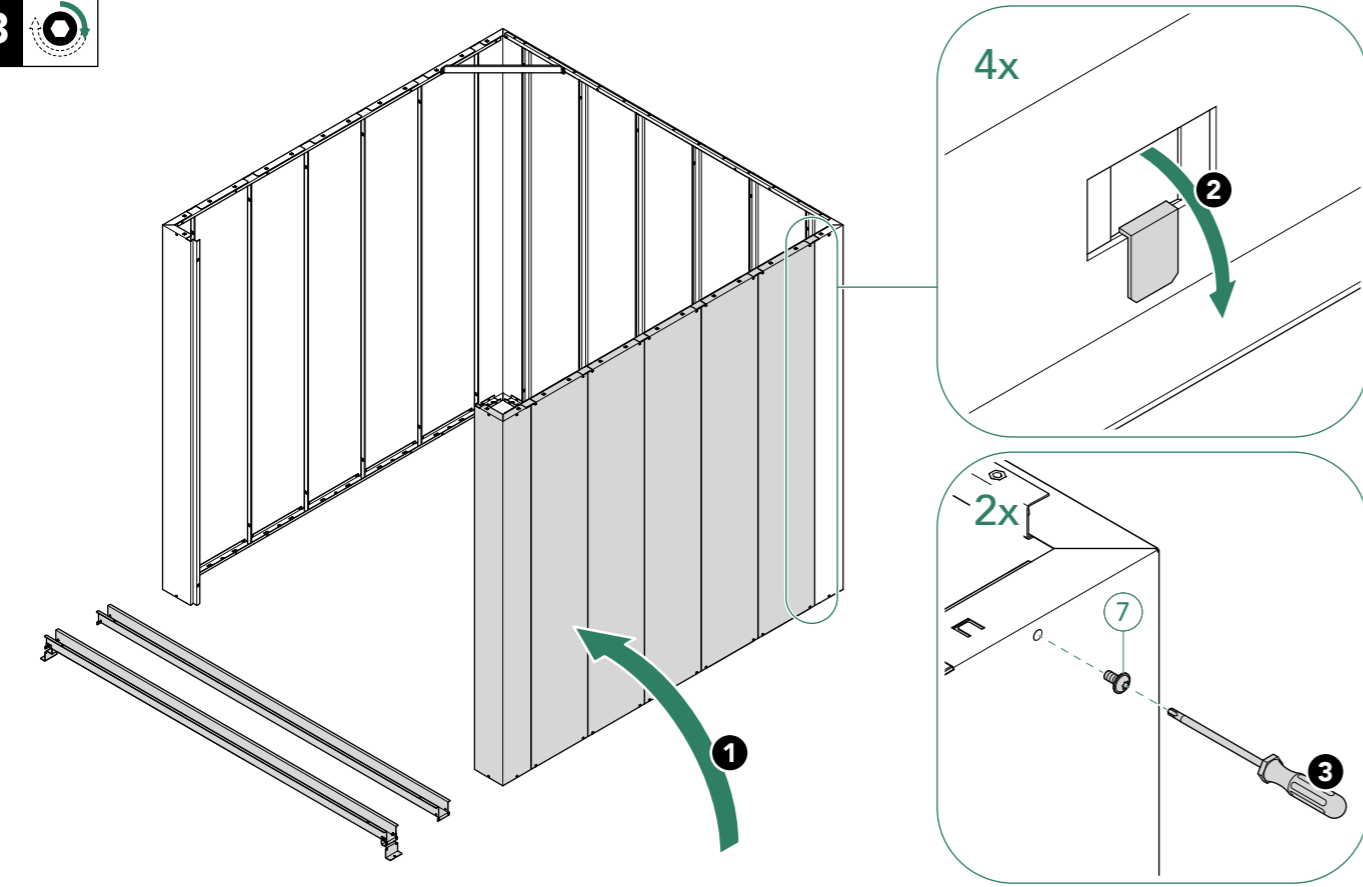

19

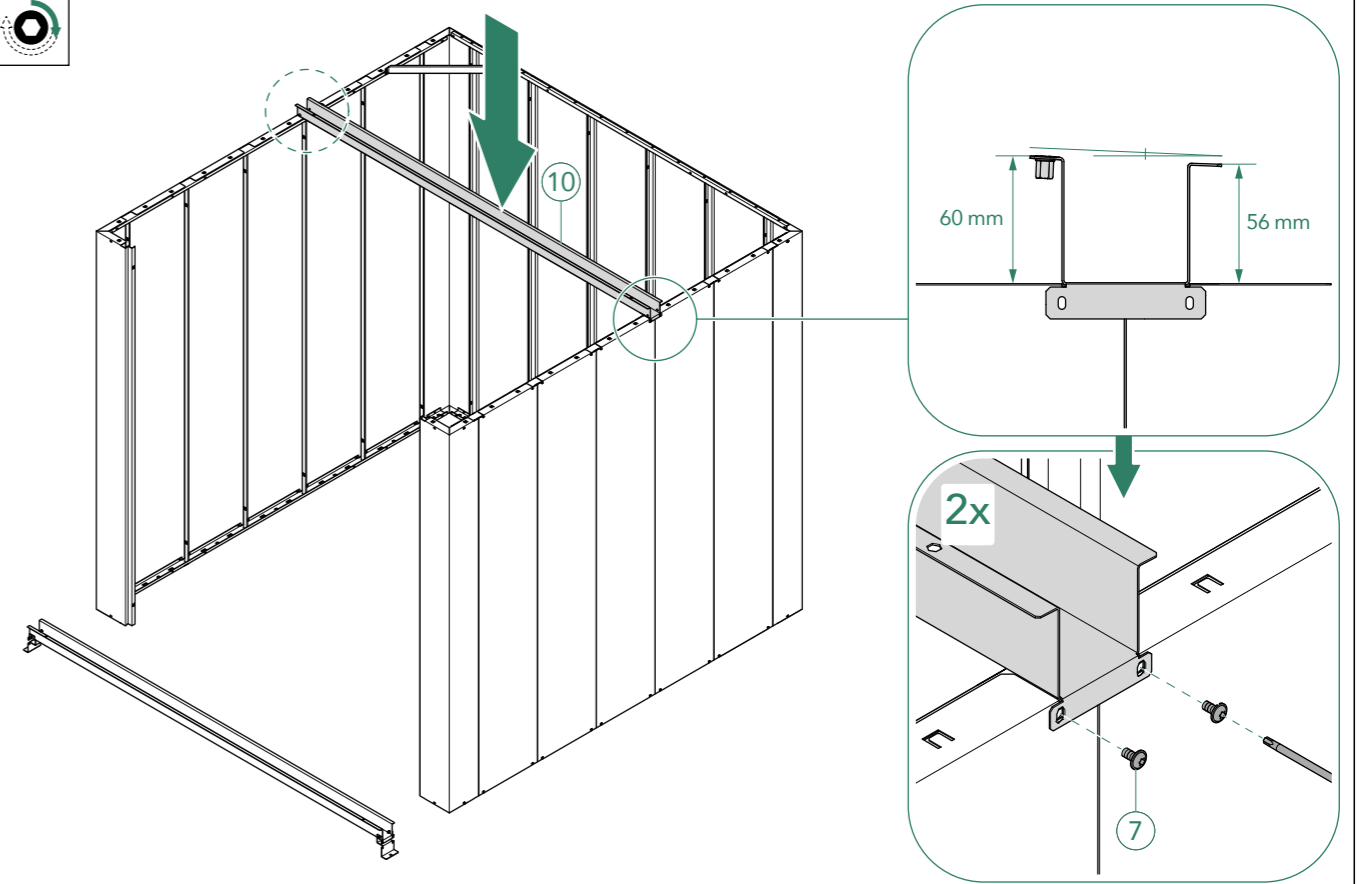

20

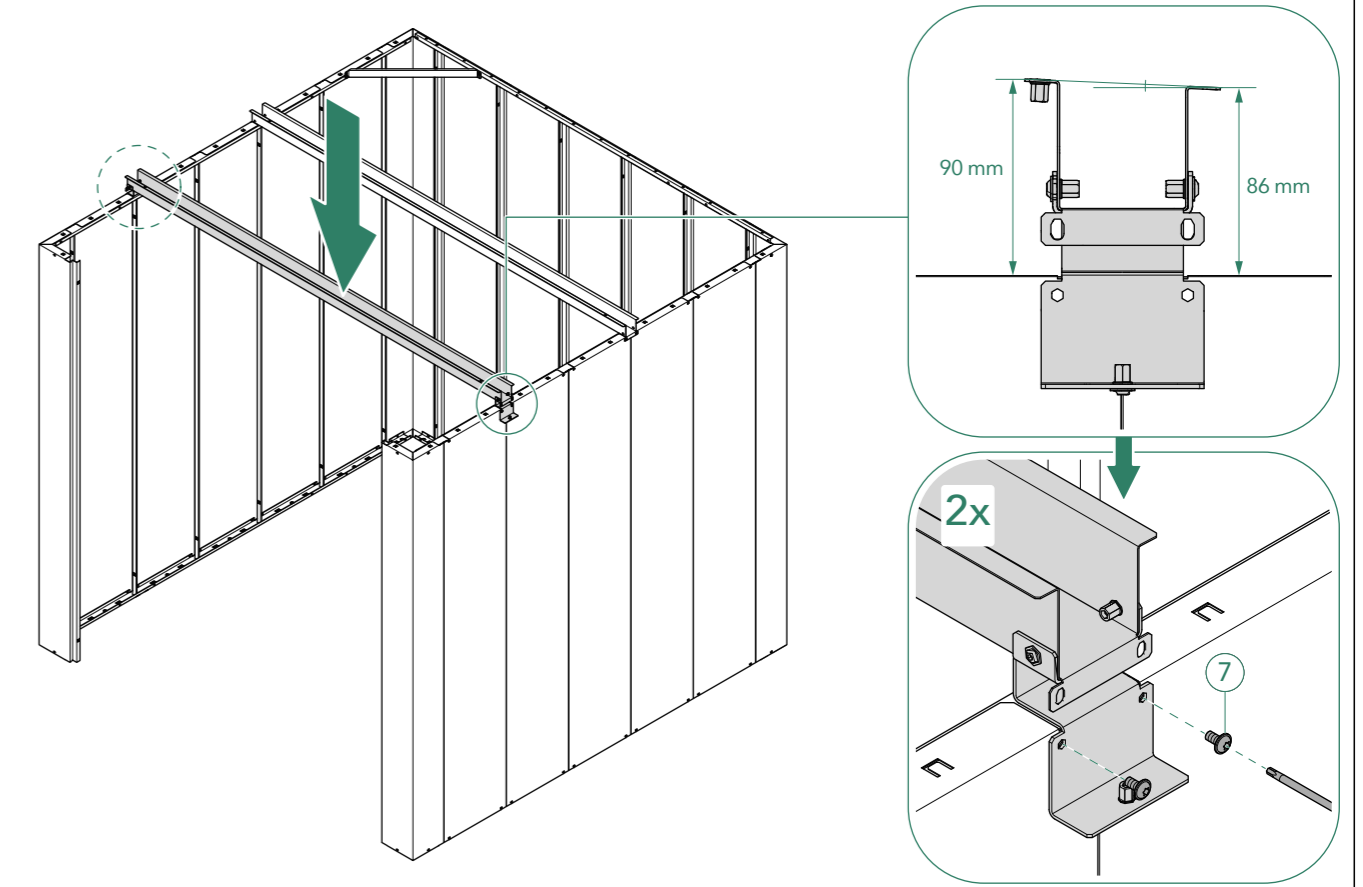

21

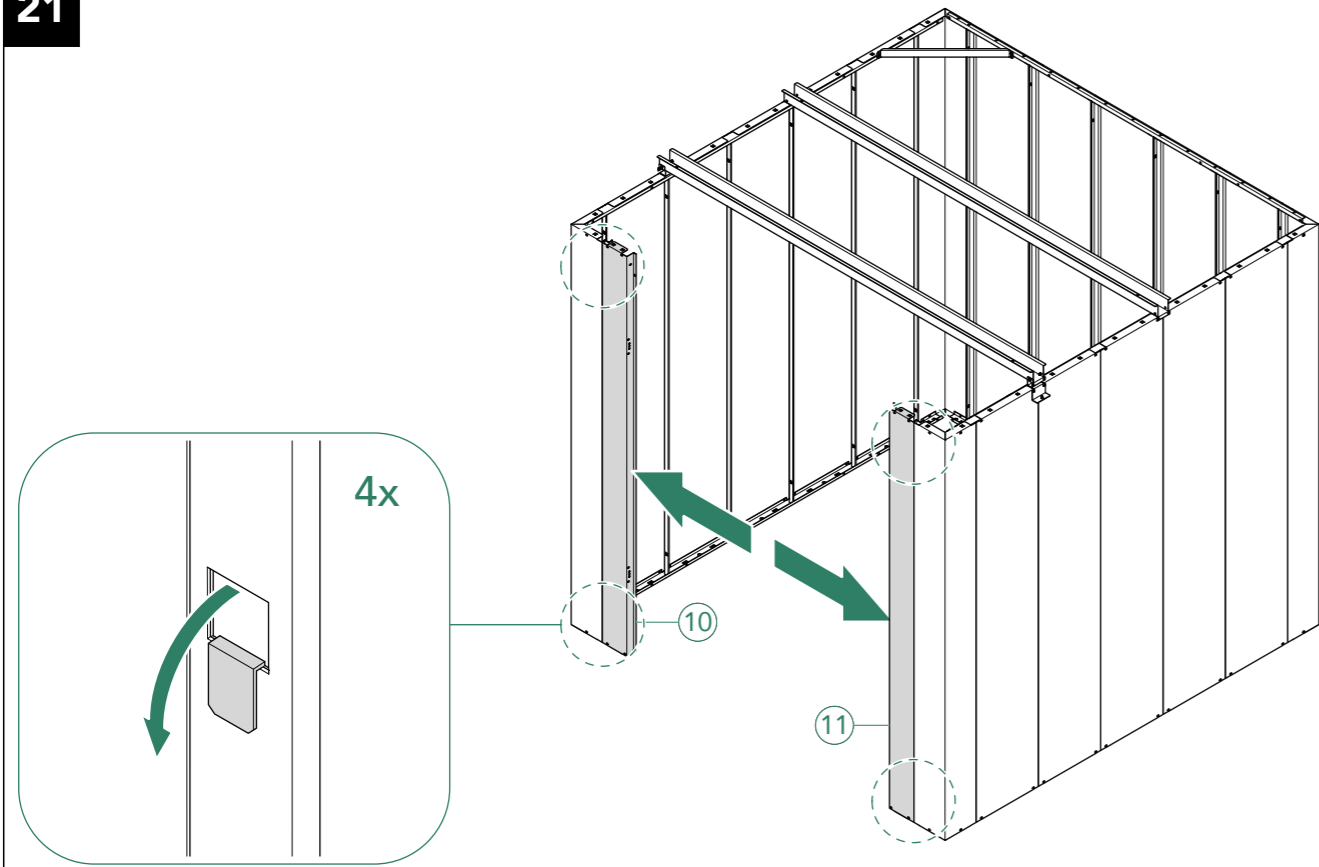

22

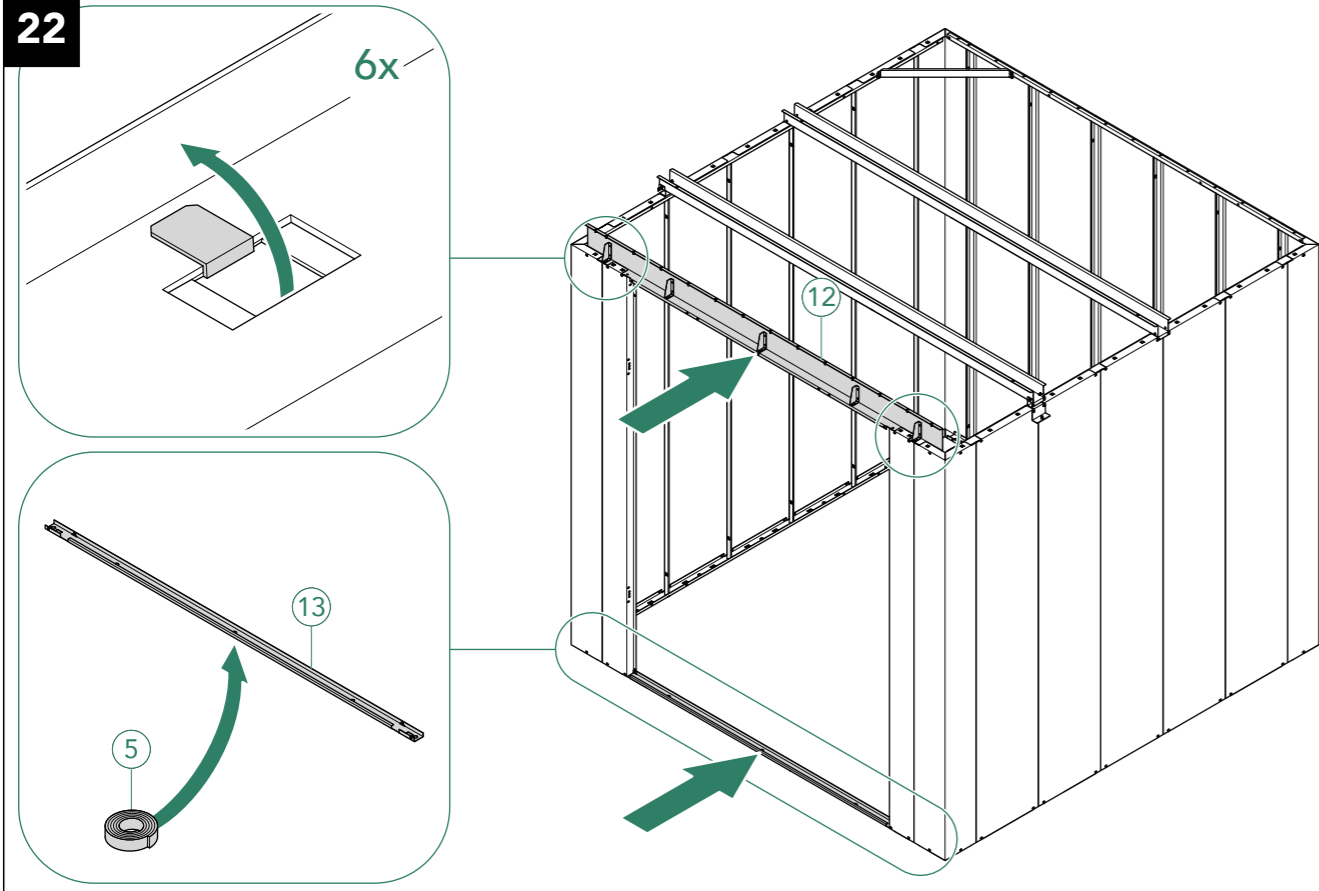

26

23

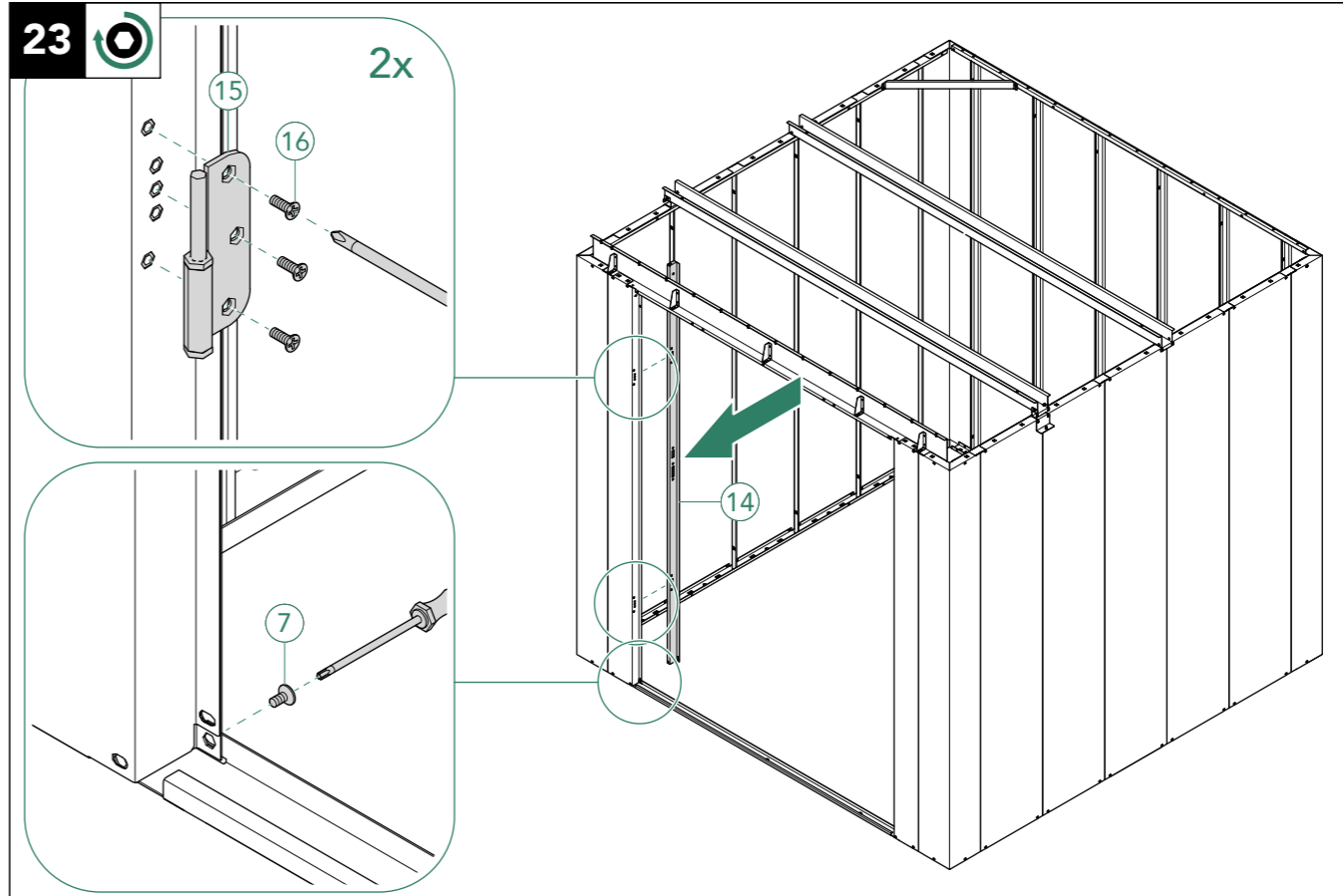

24

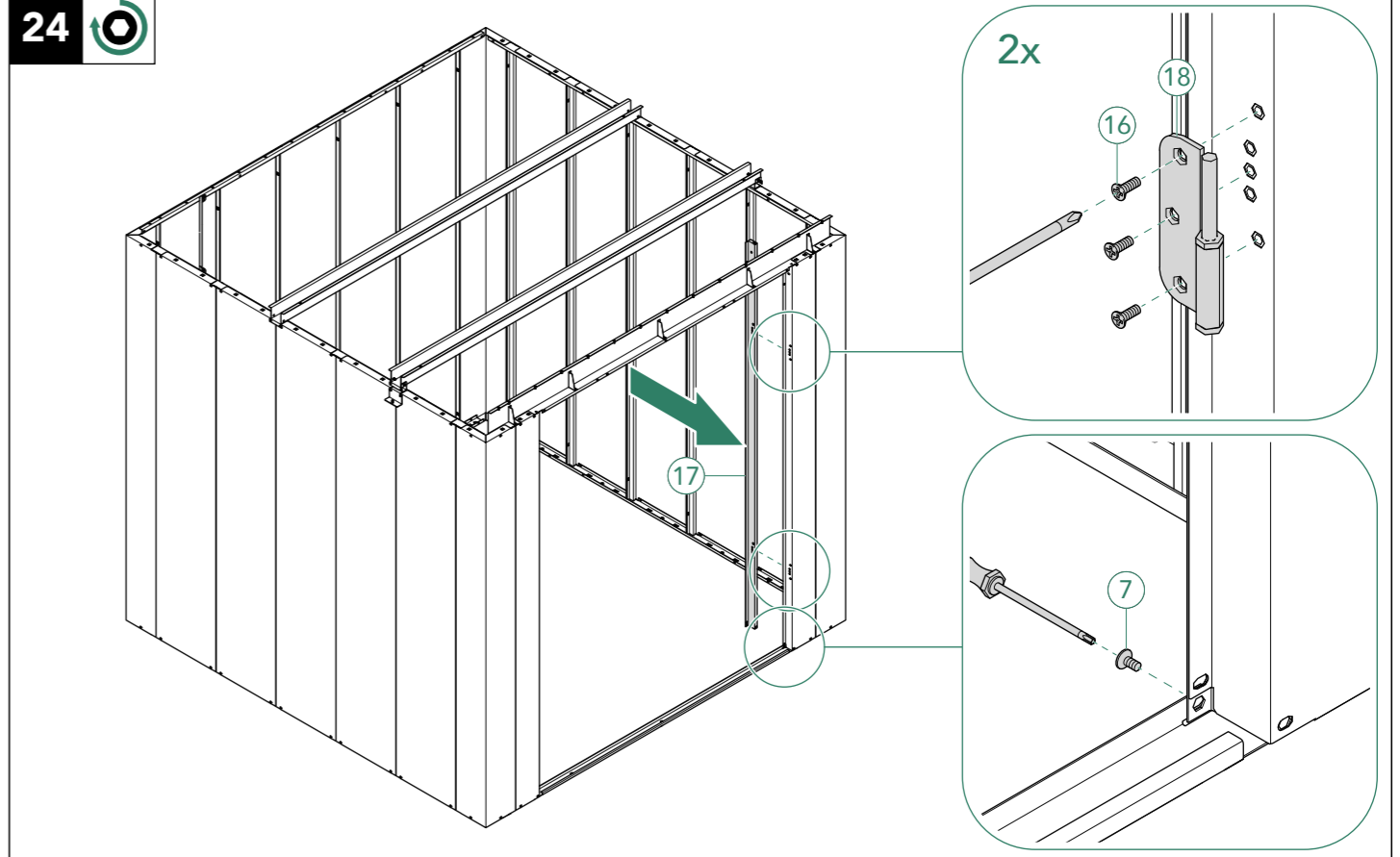

27

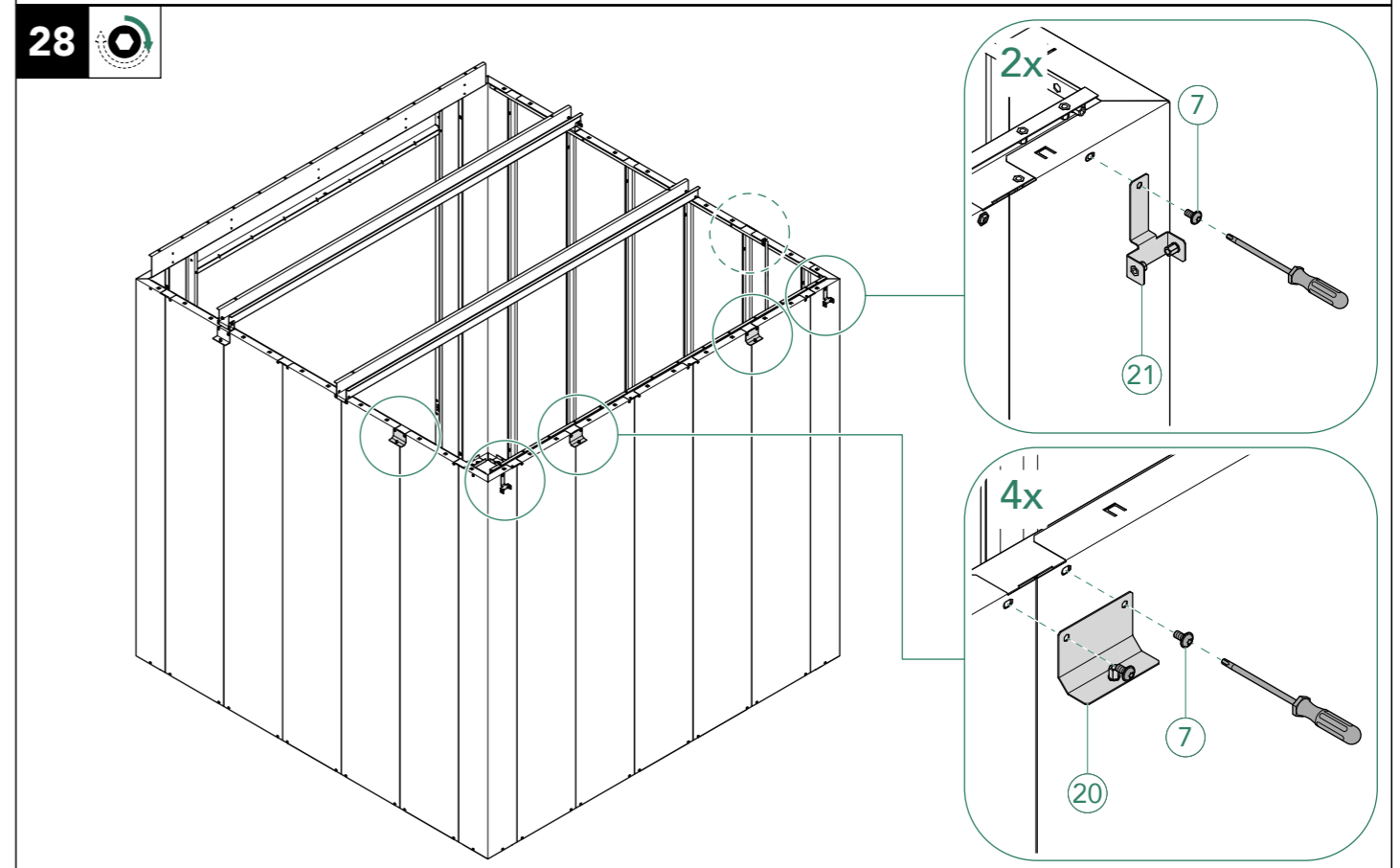
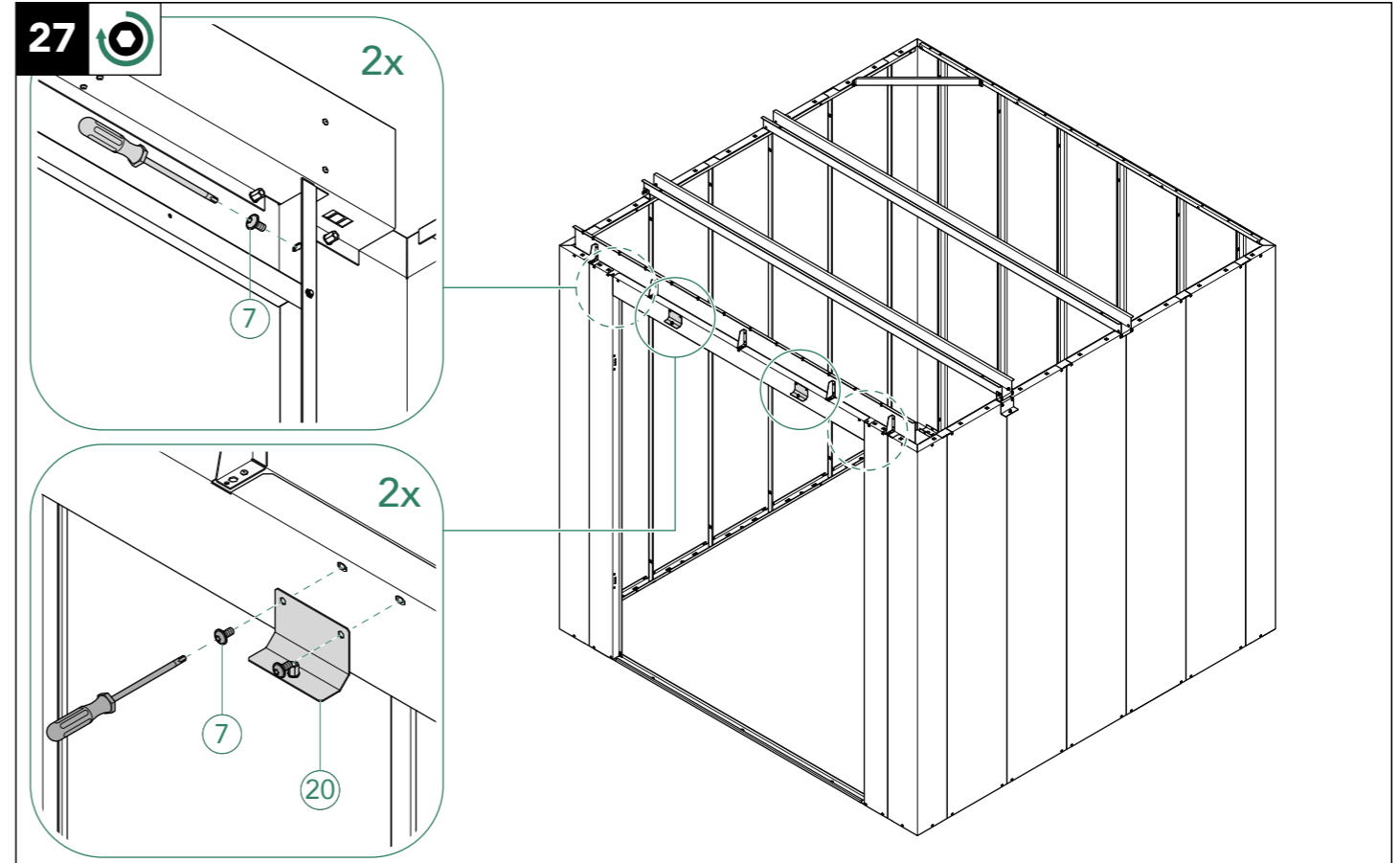
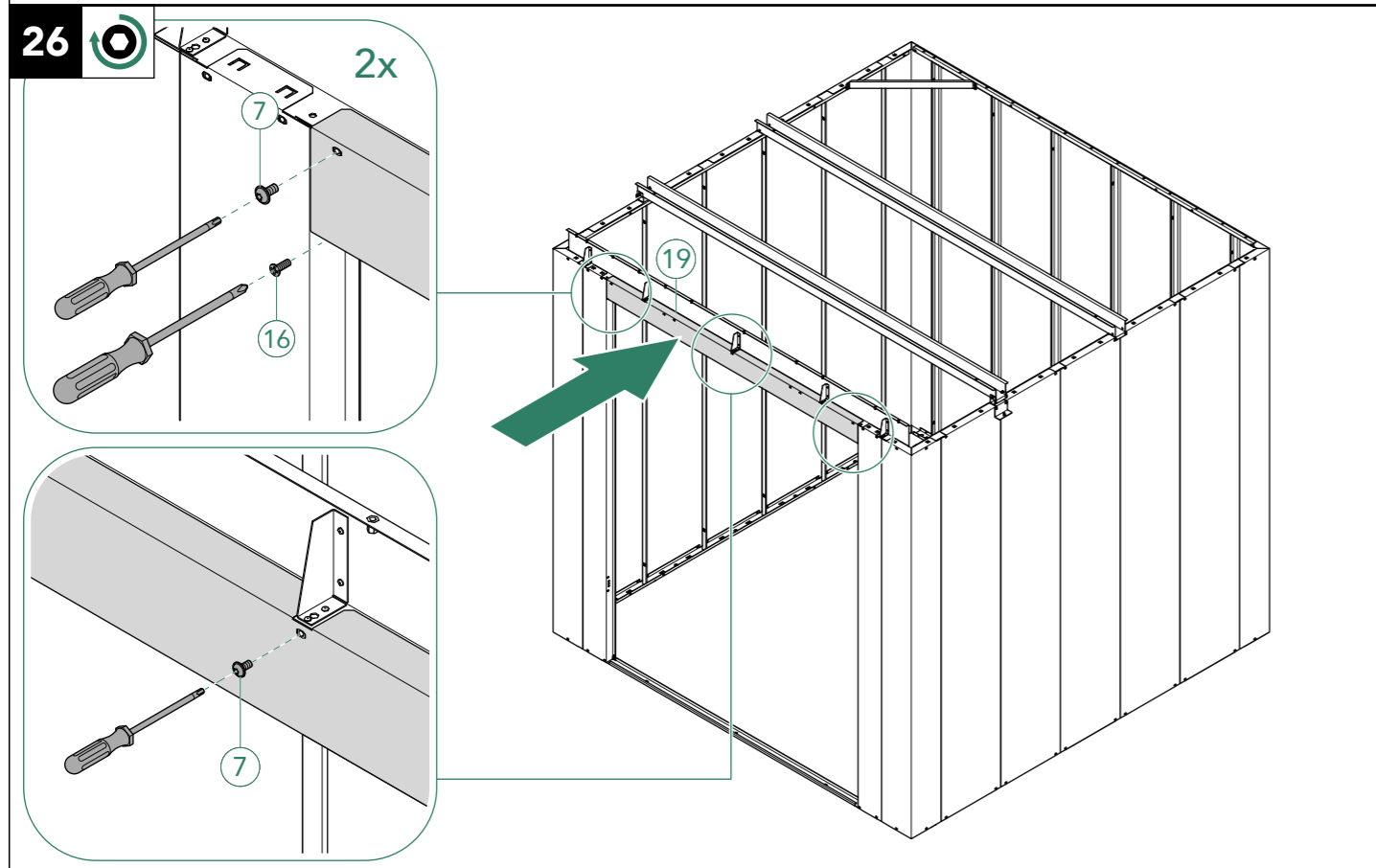
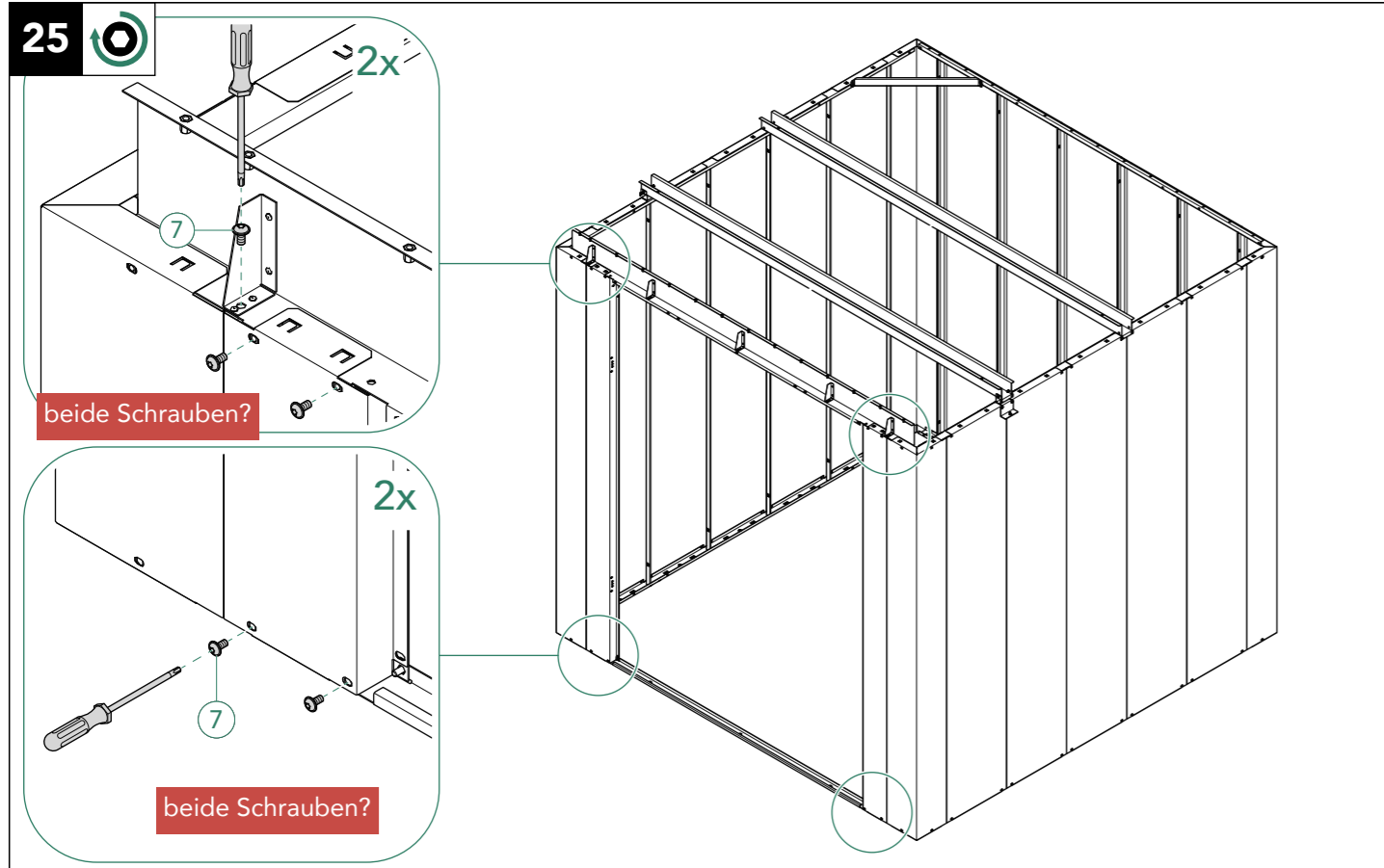

29

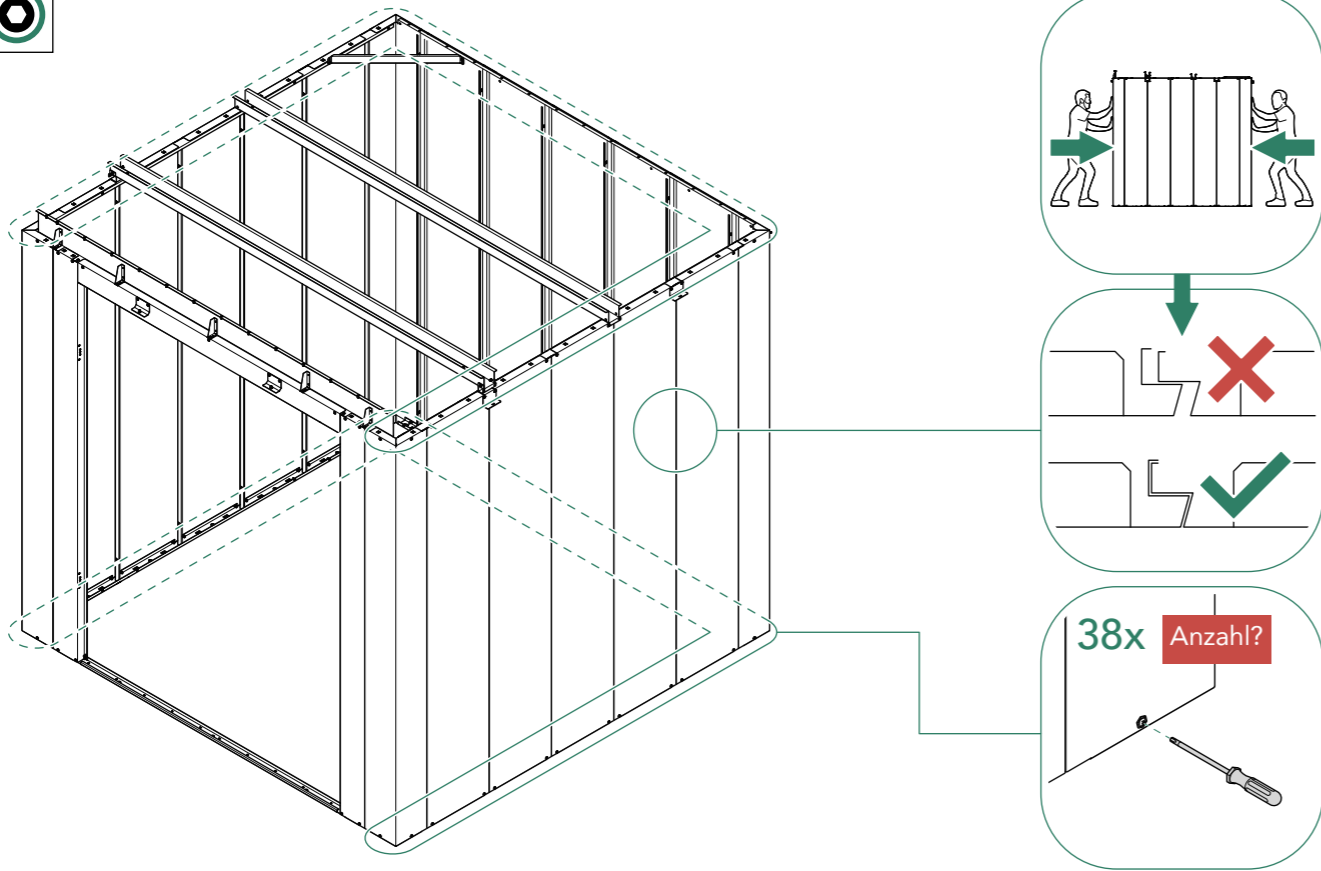

30

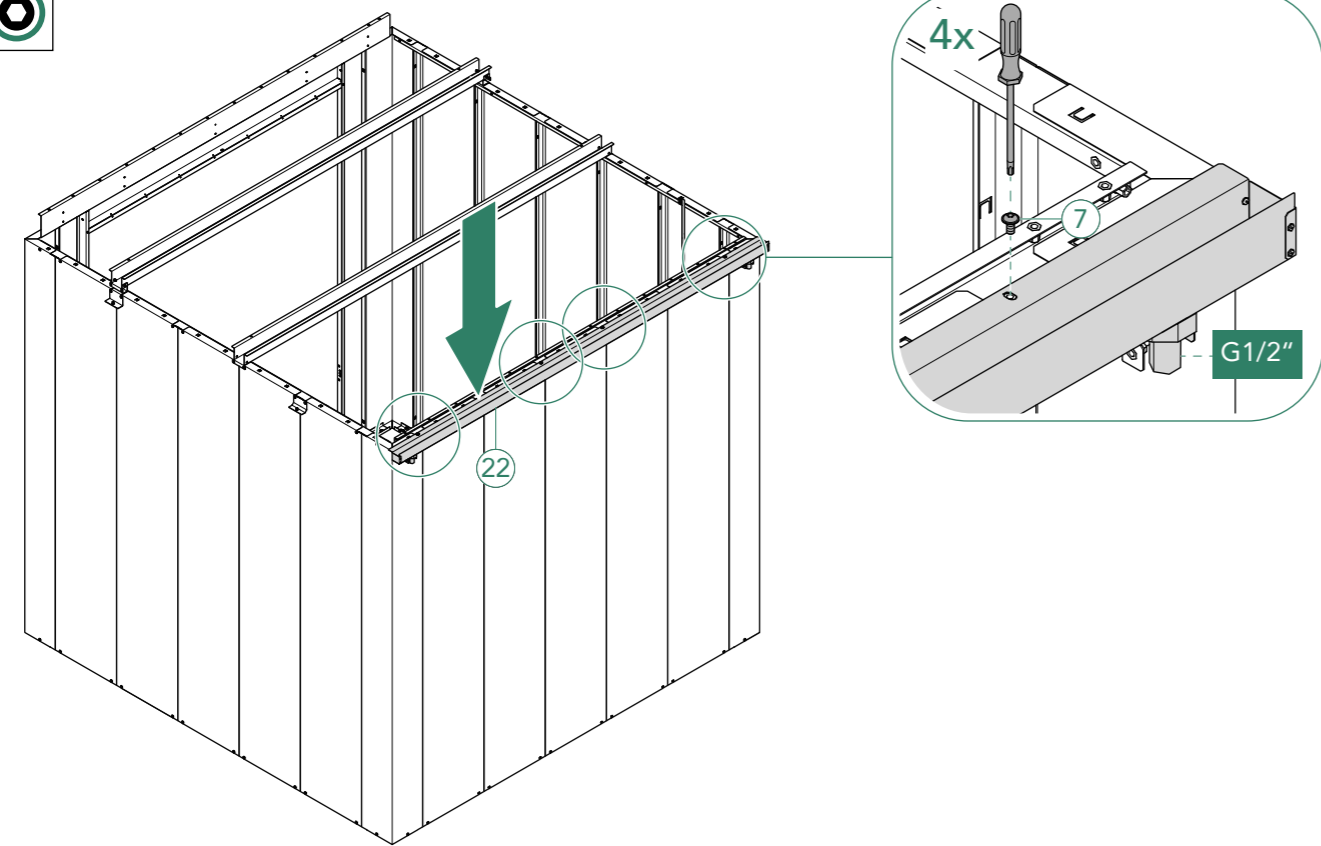

31

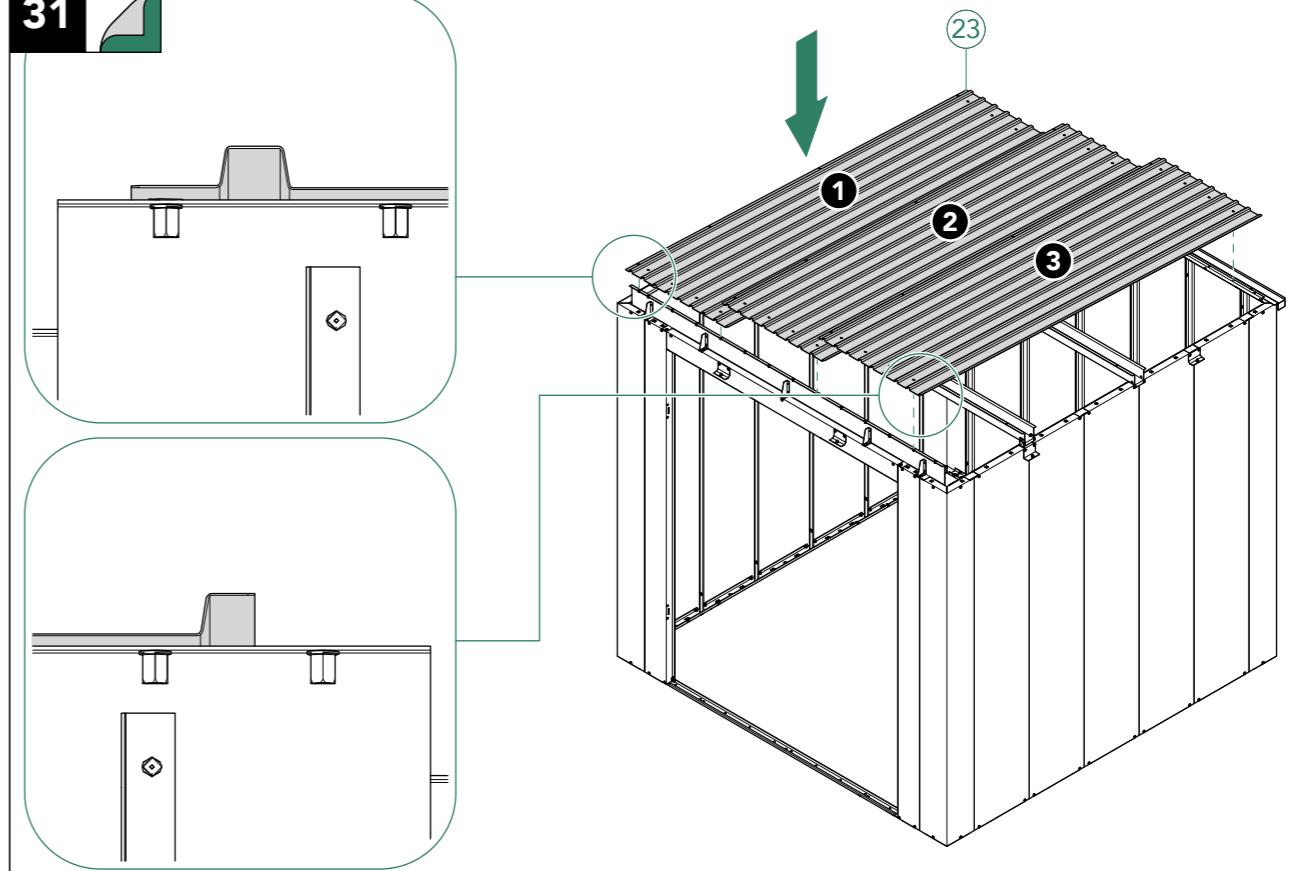

32

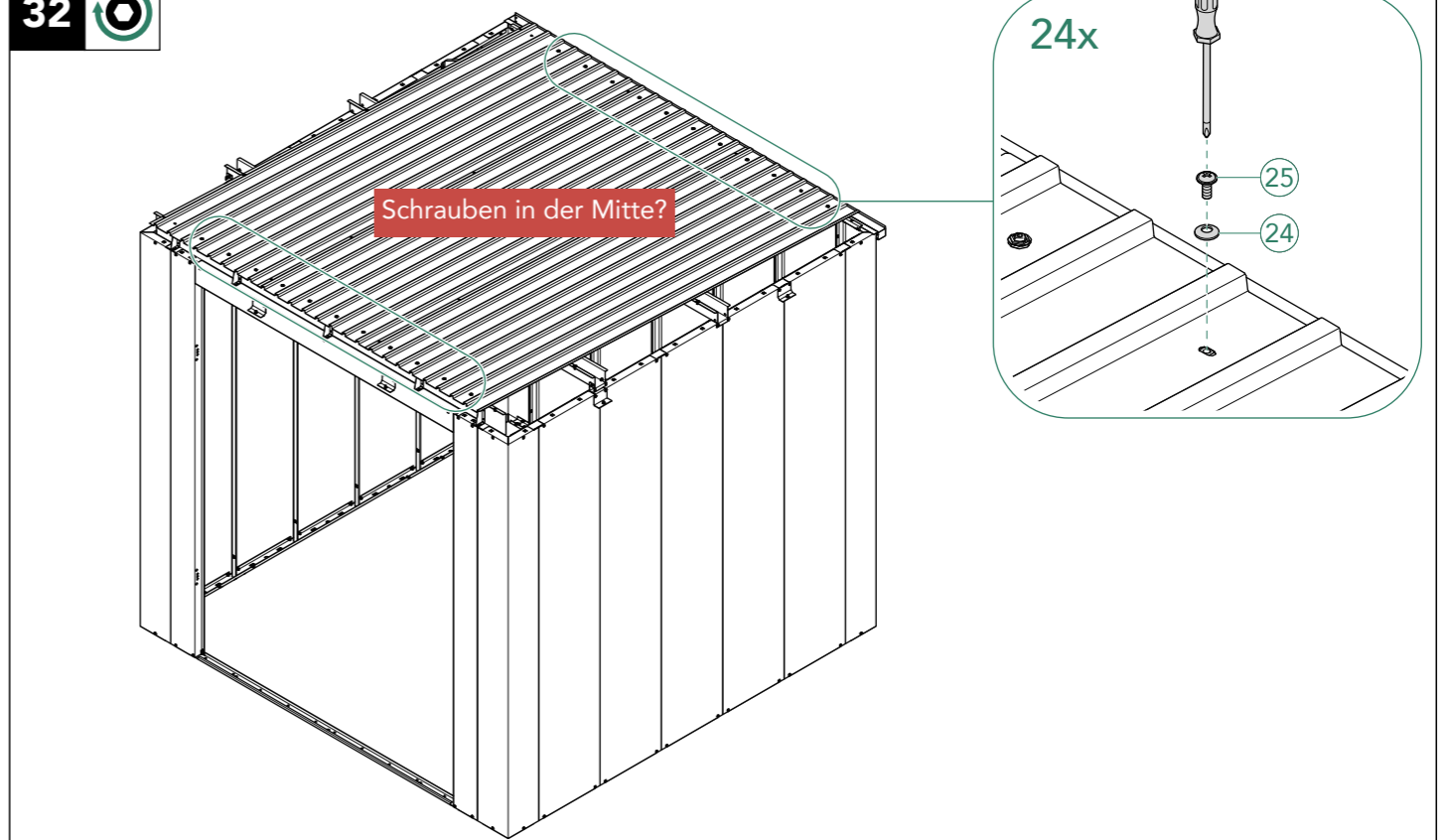

33

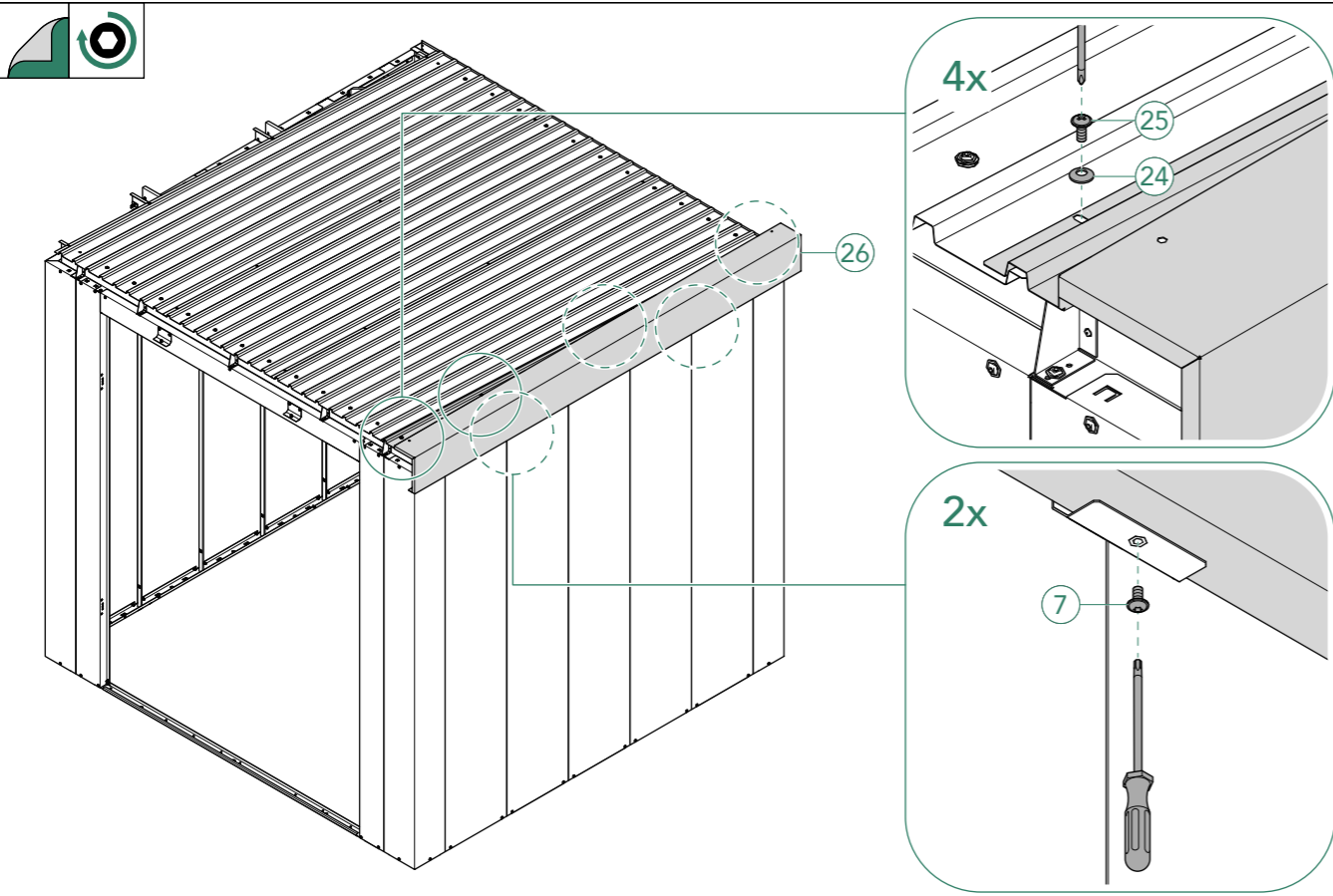

34

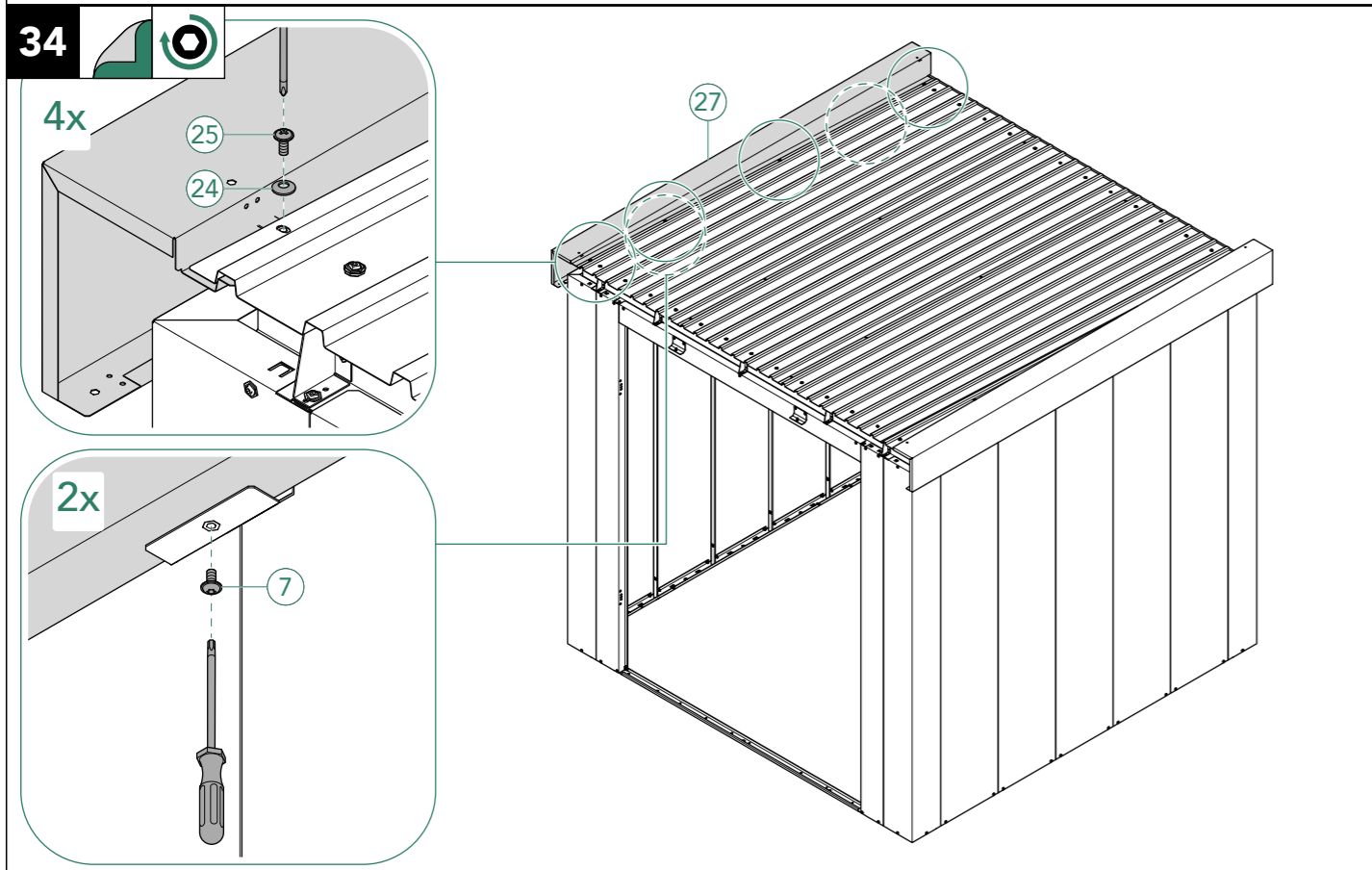

35

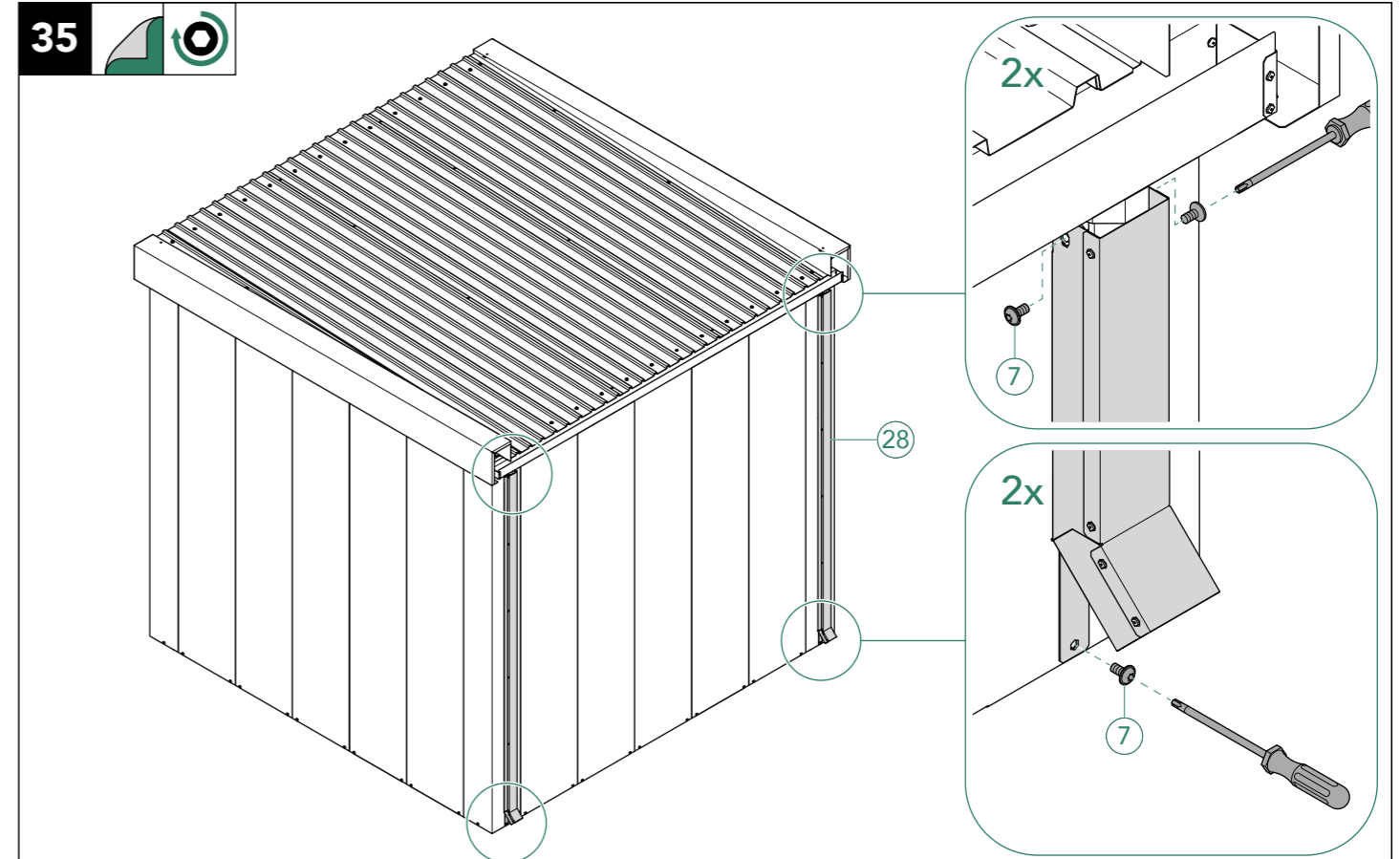

36

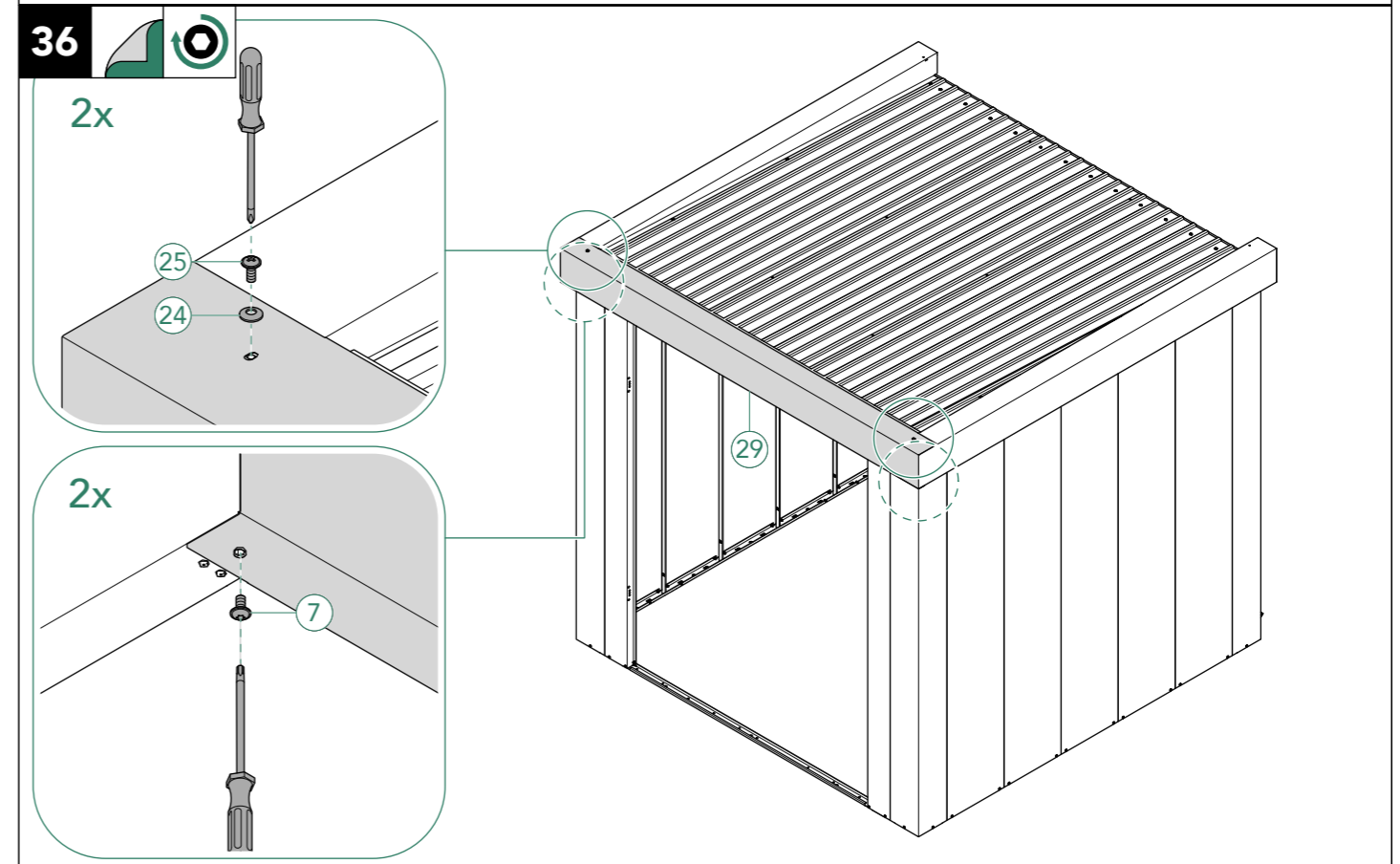

37

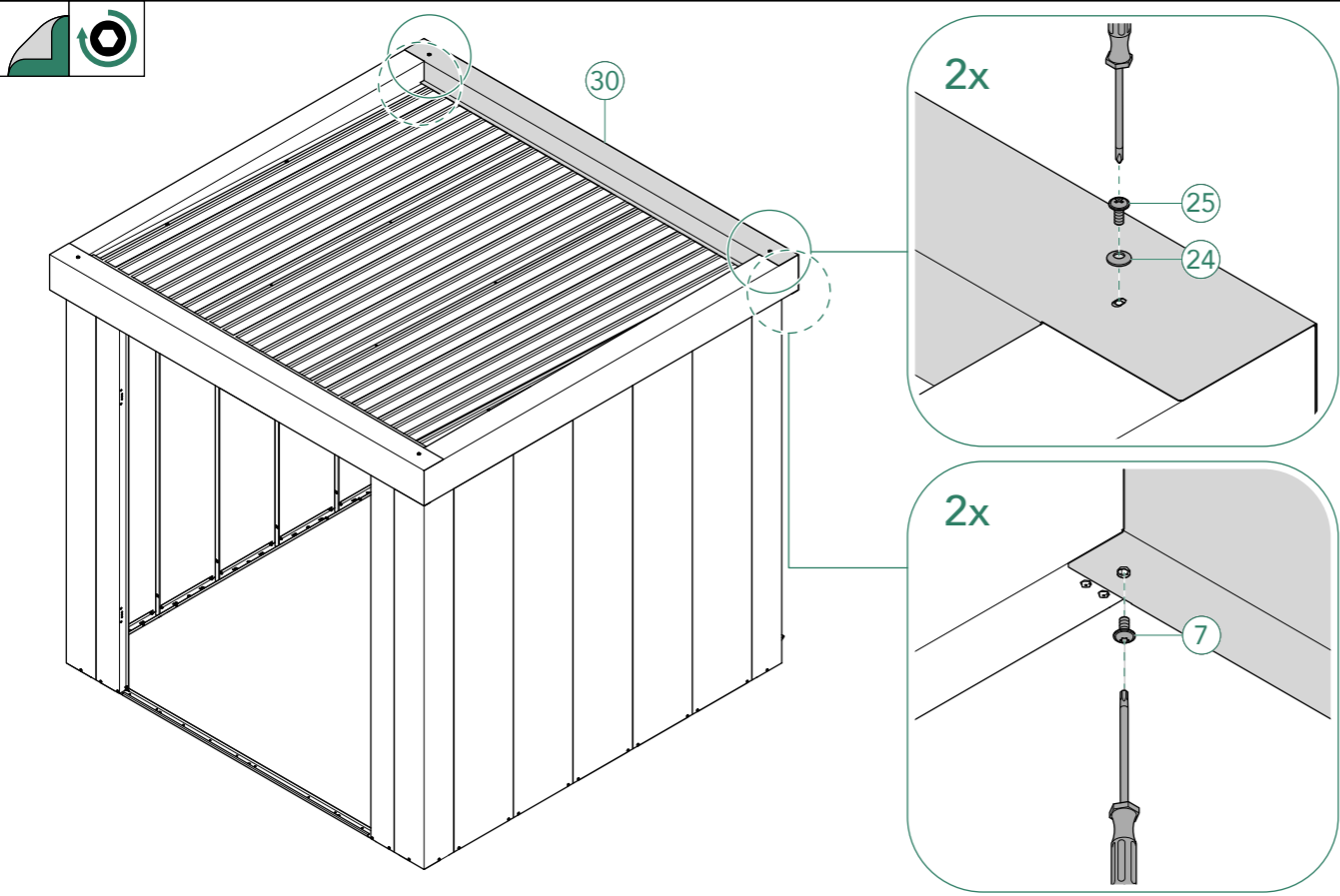

38

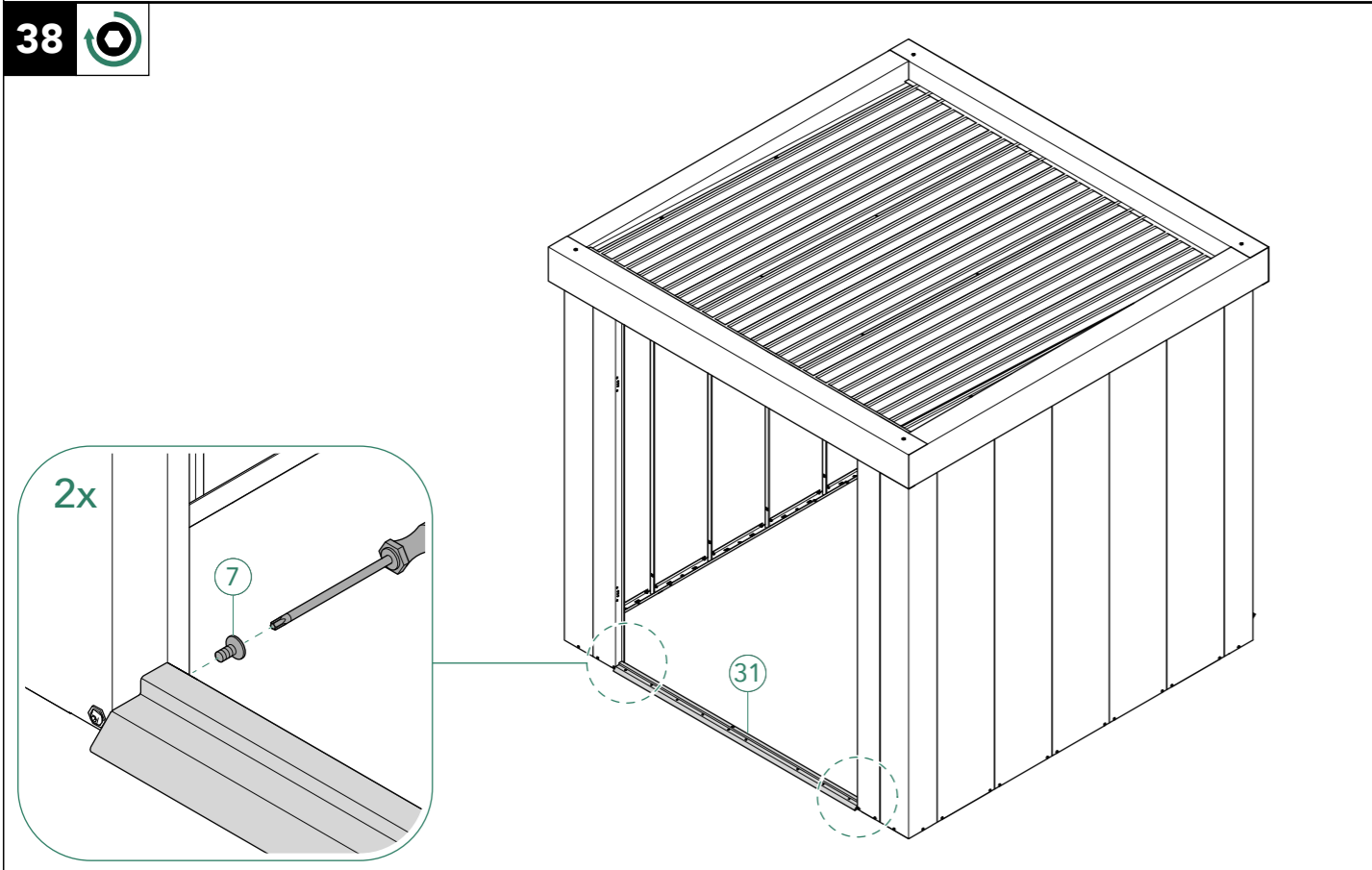

39

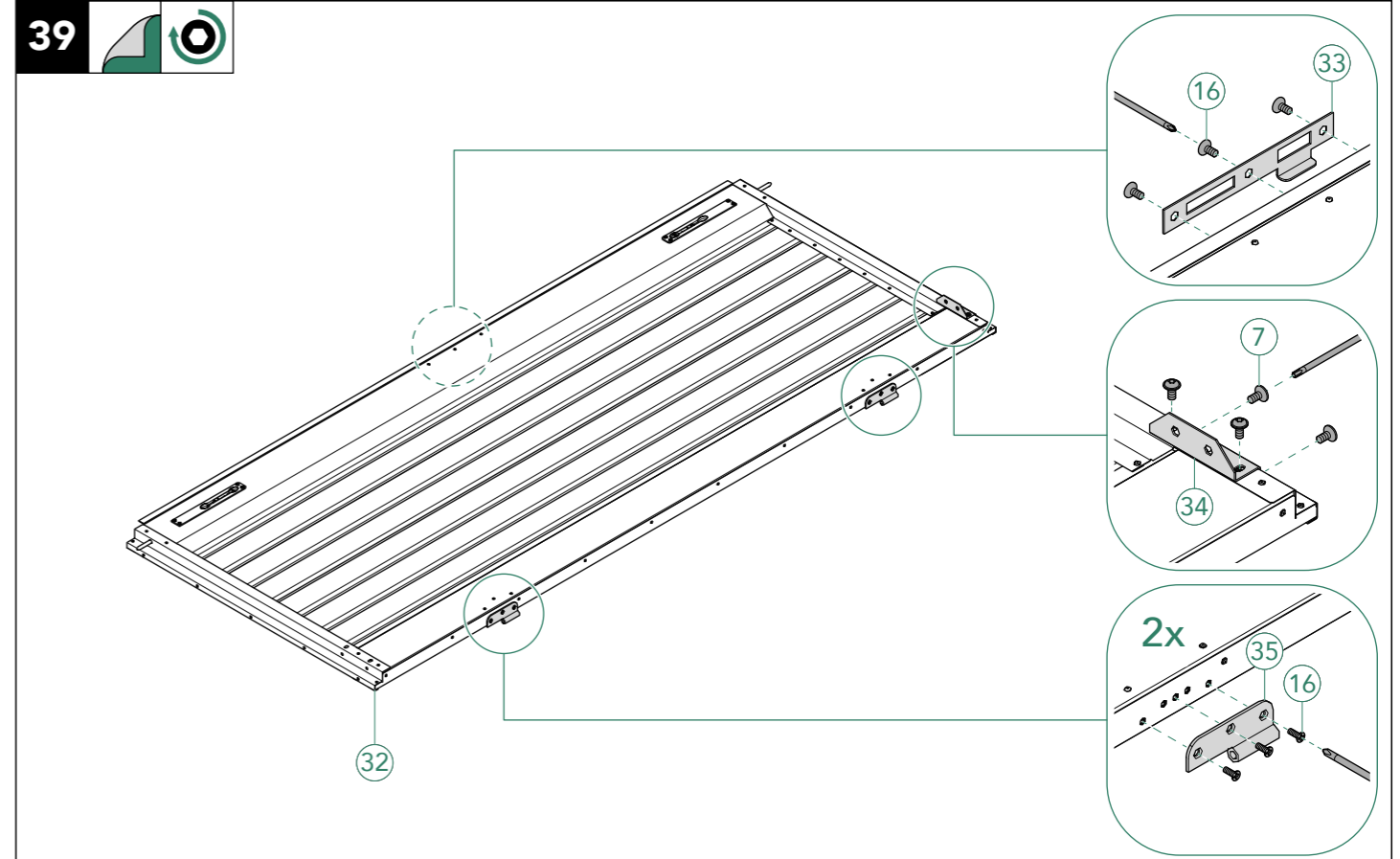

40

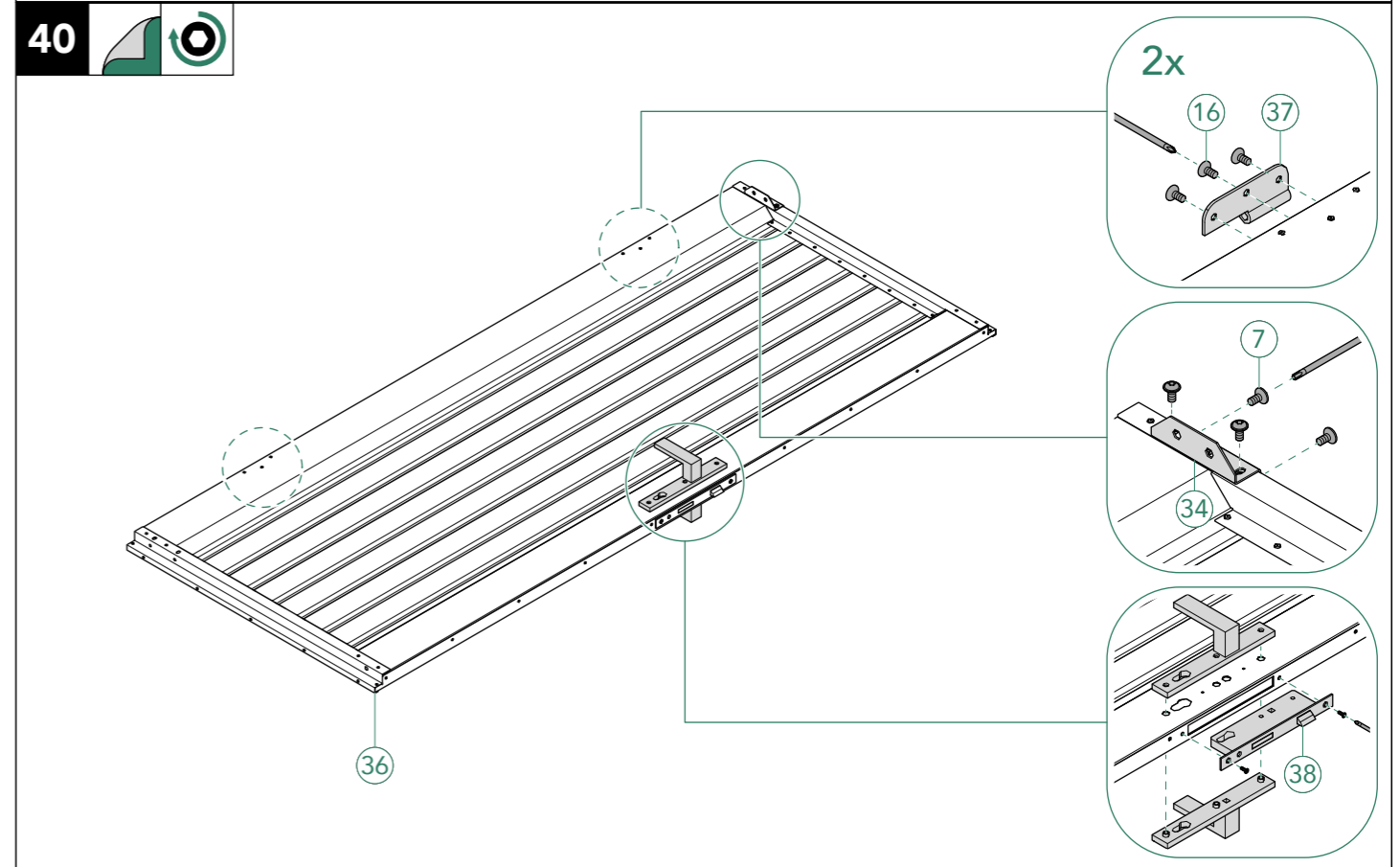

41

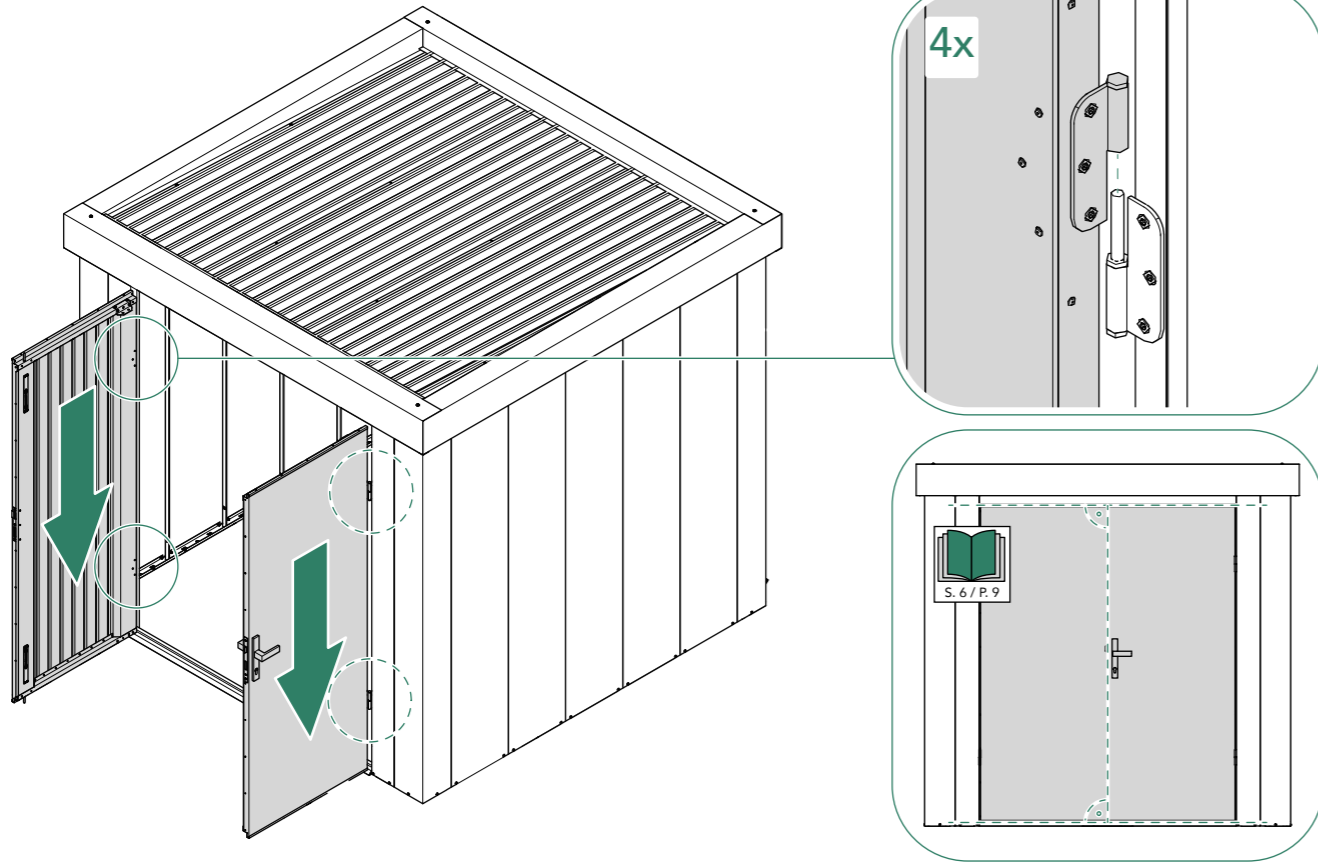

42

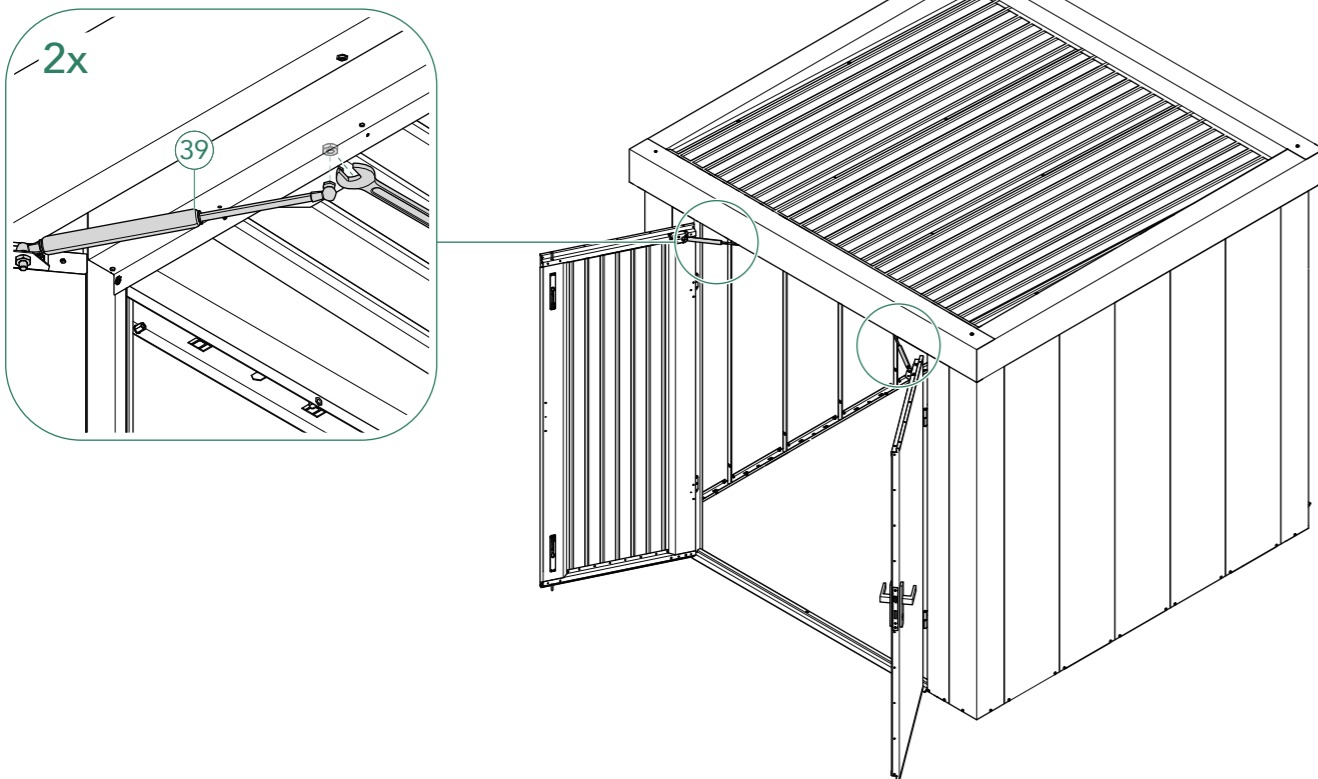

43

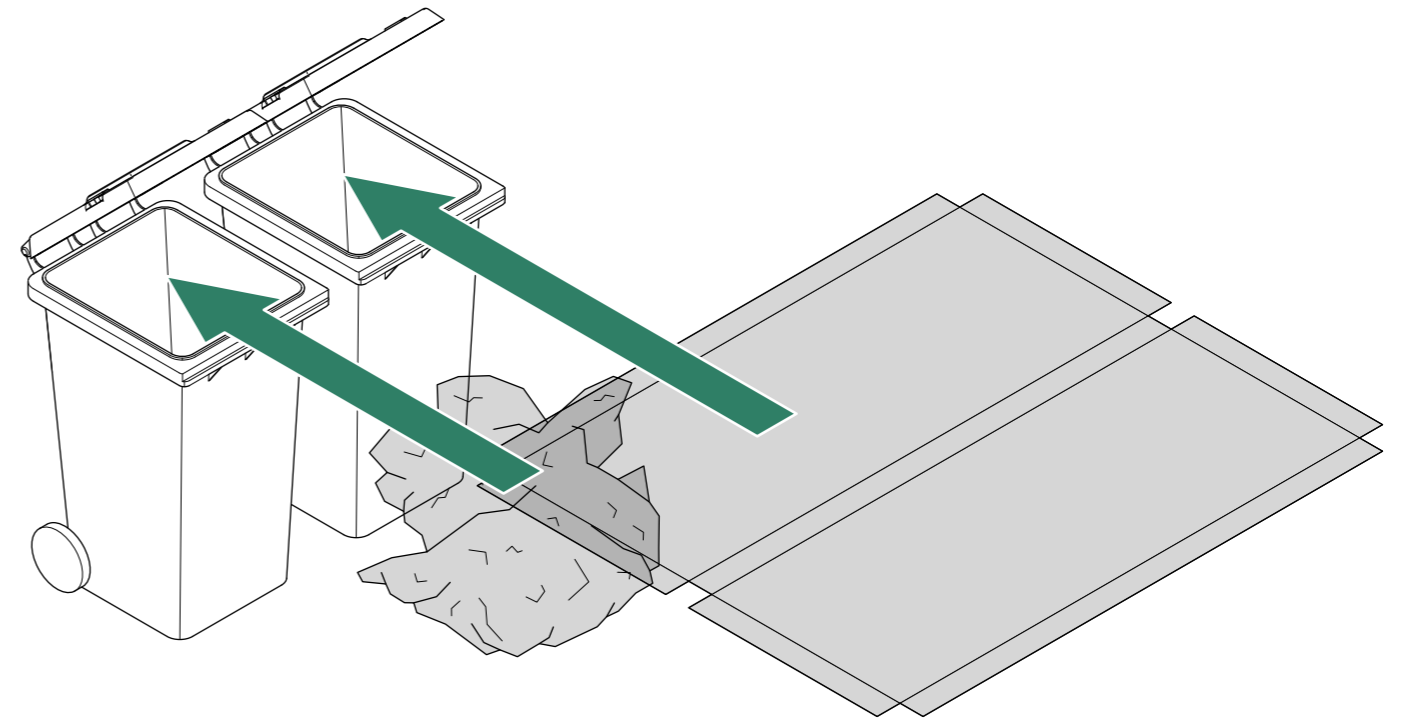

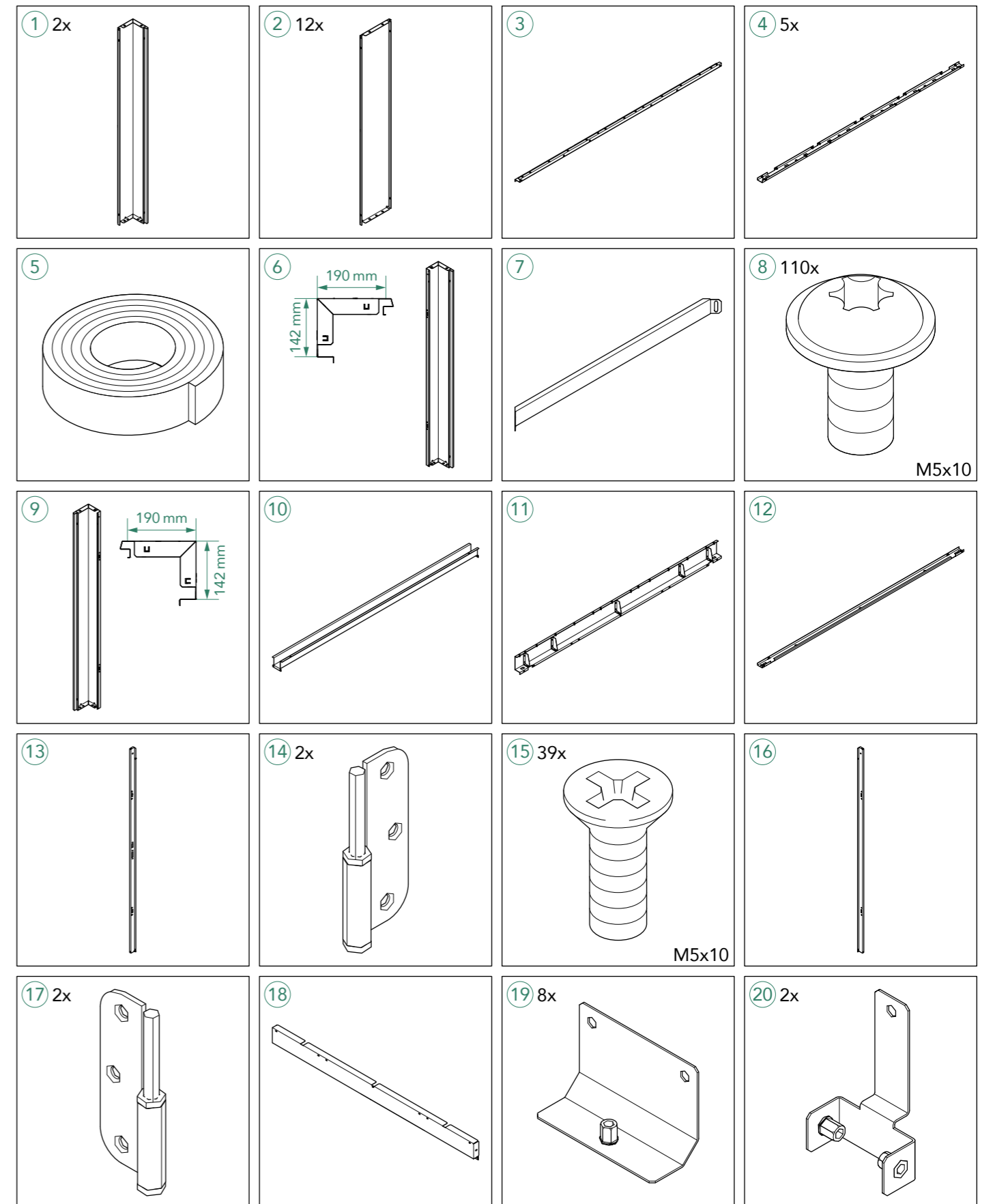
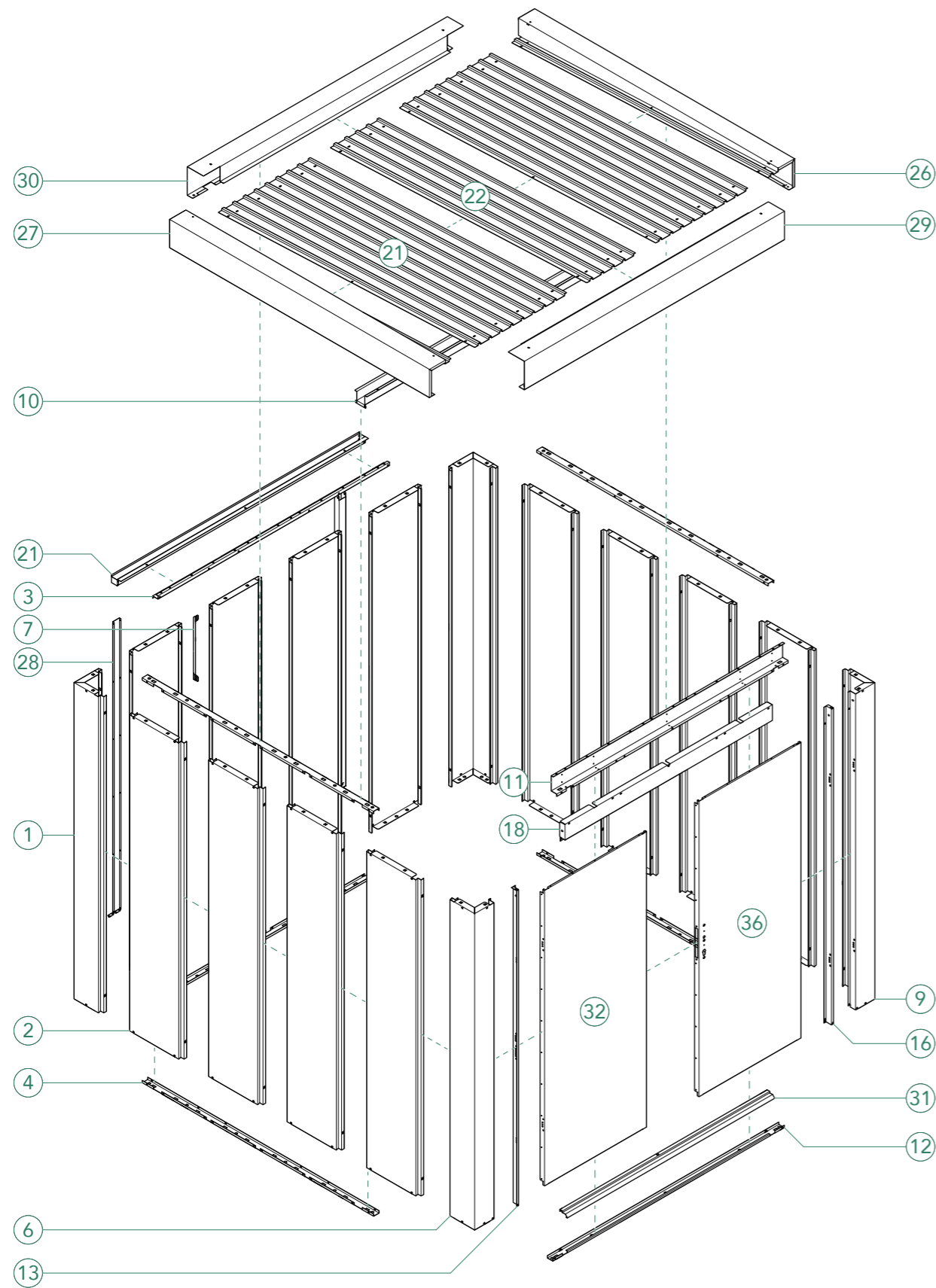

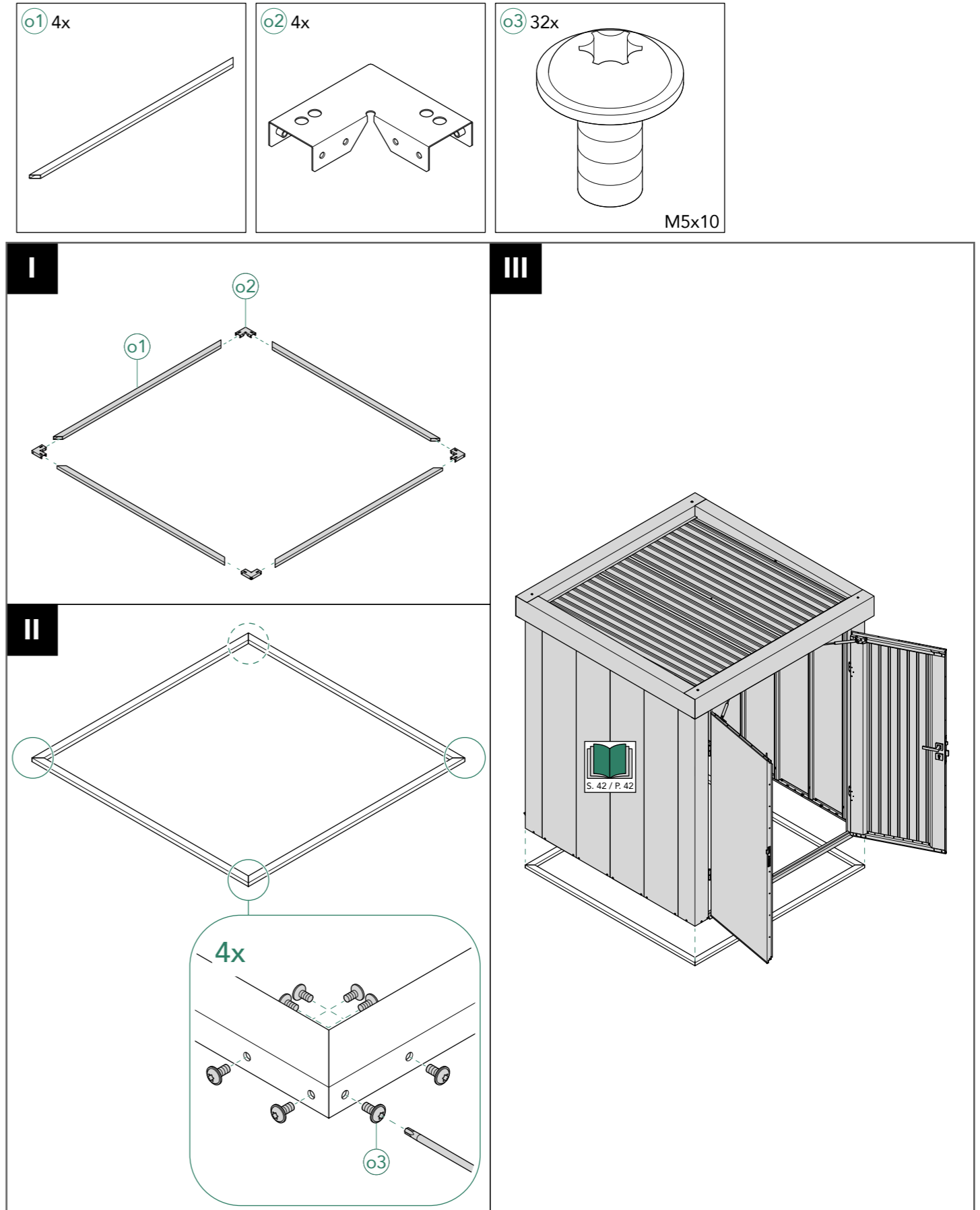
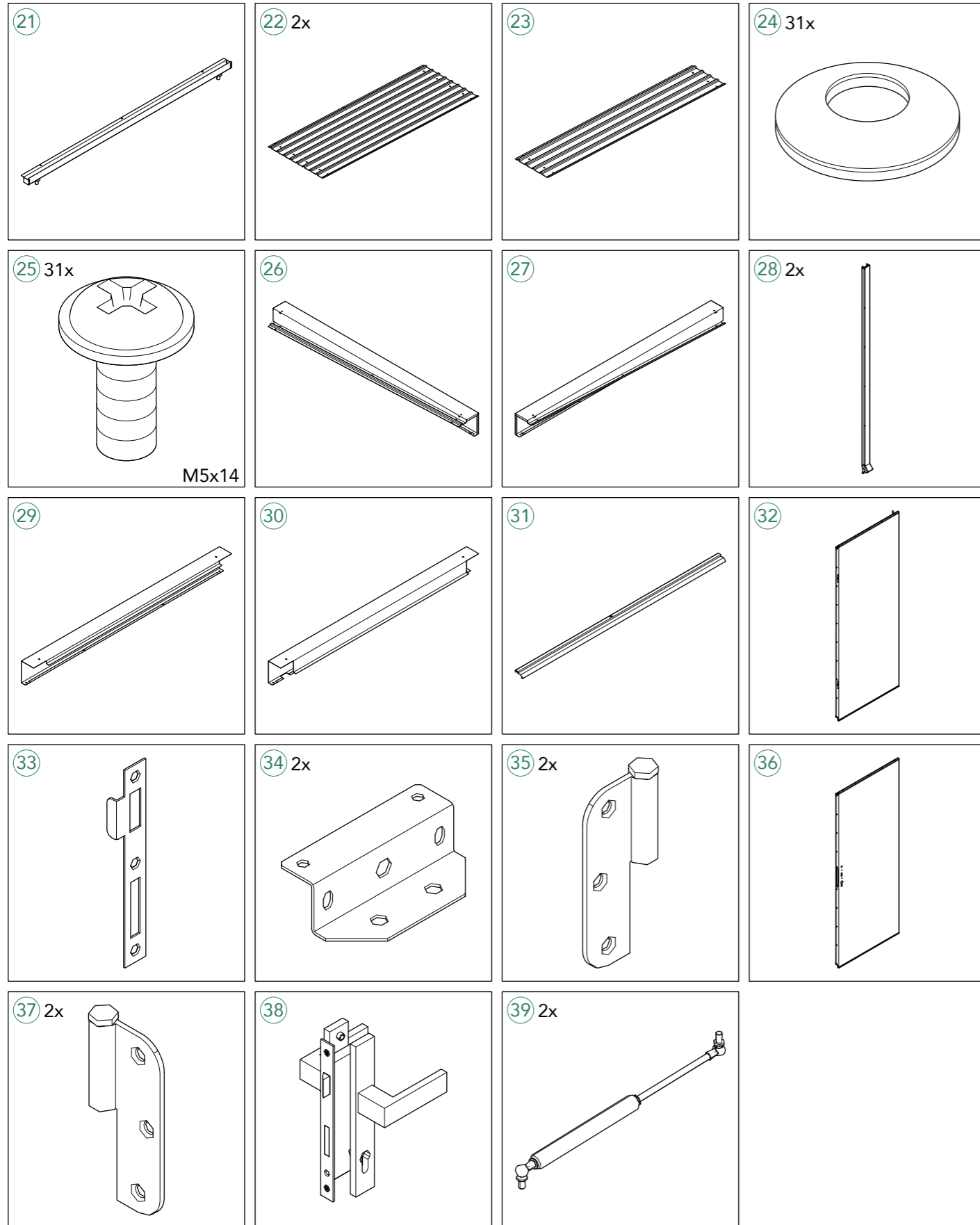

01

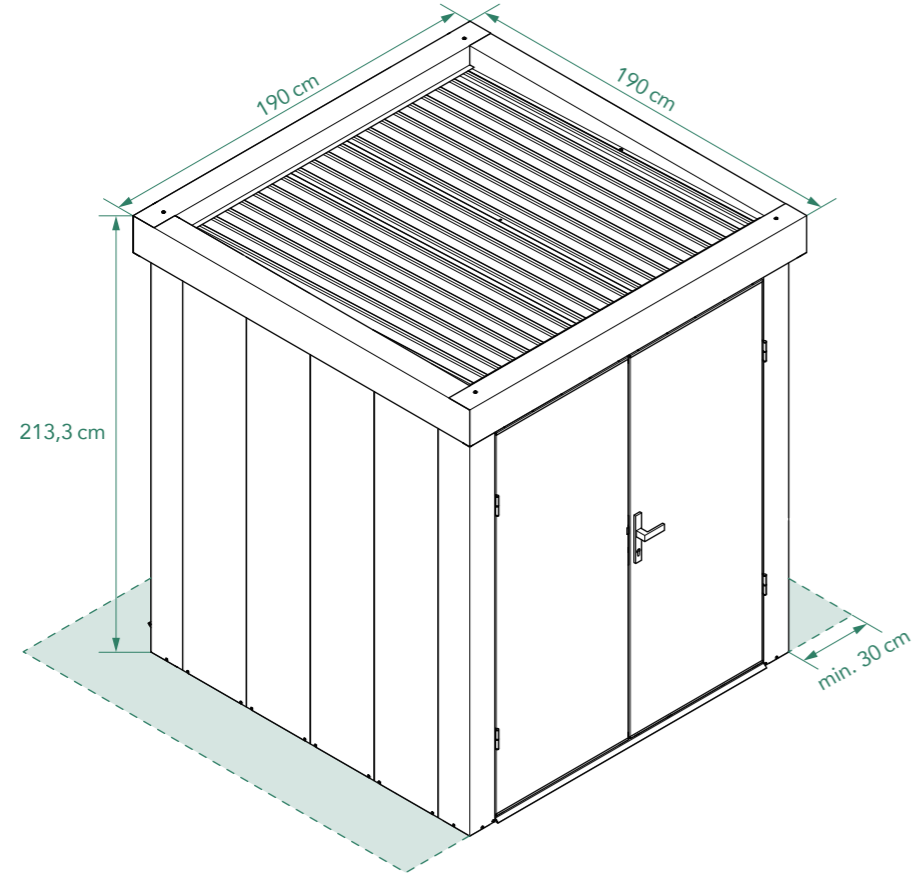

02

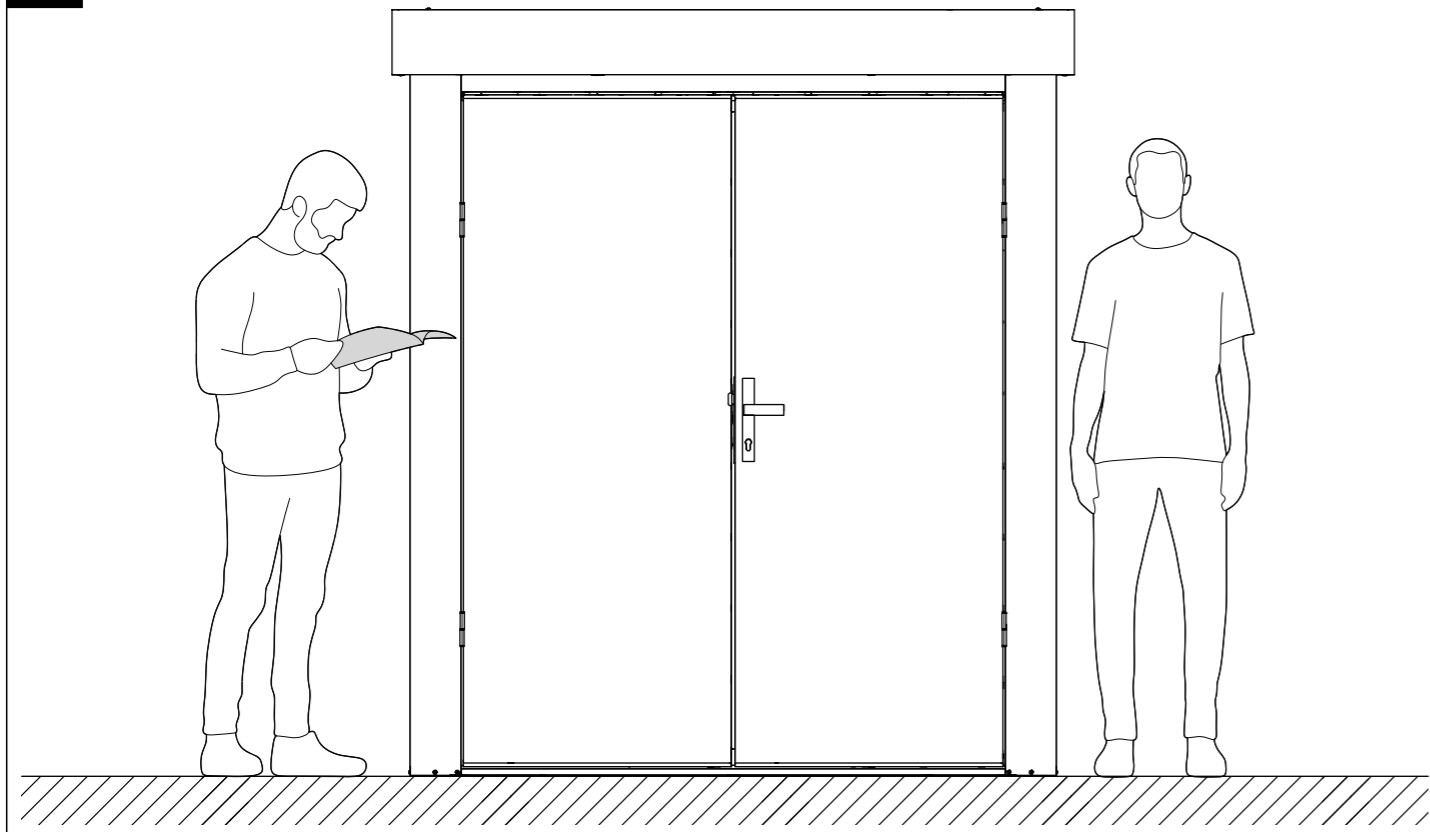

03

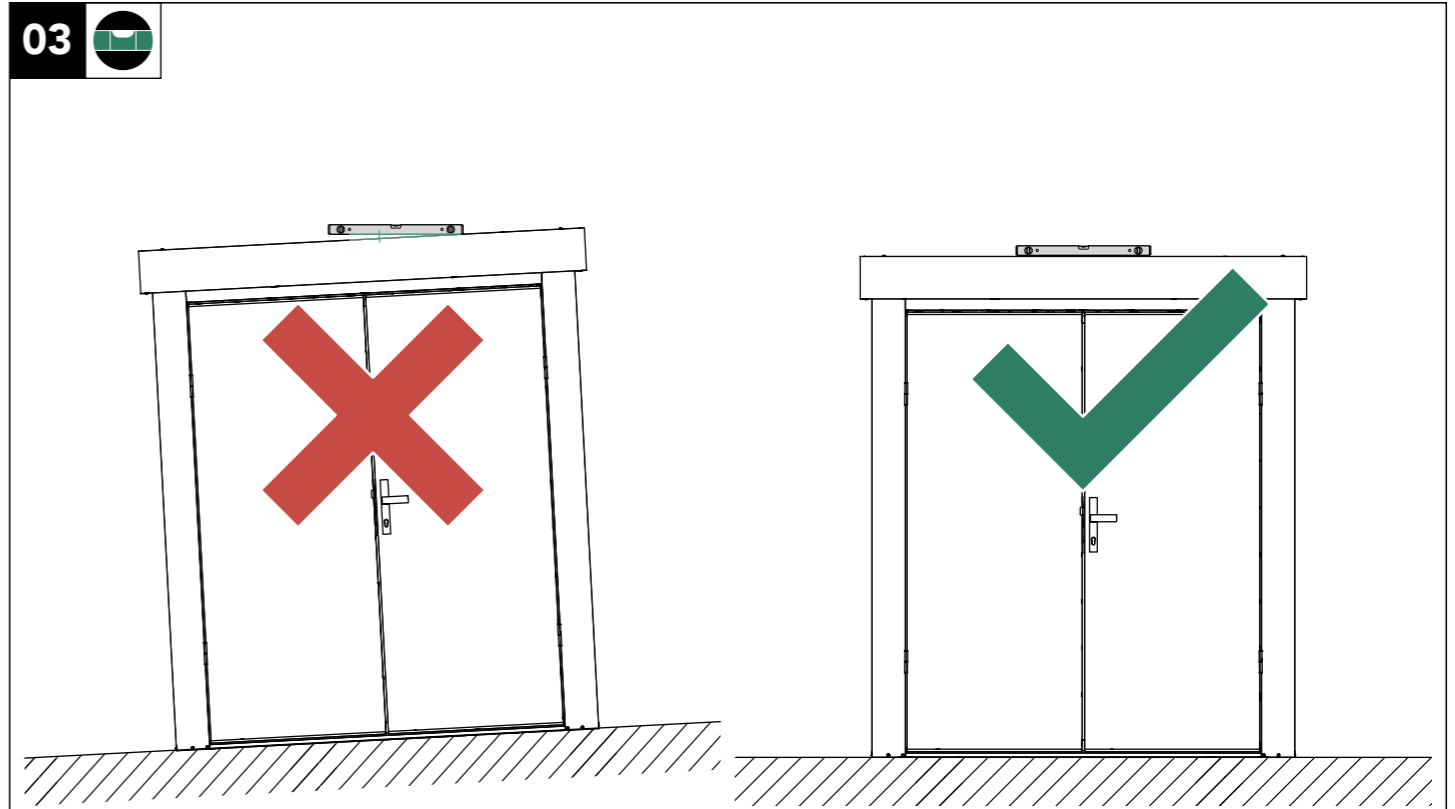

04

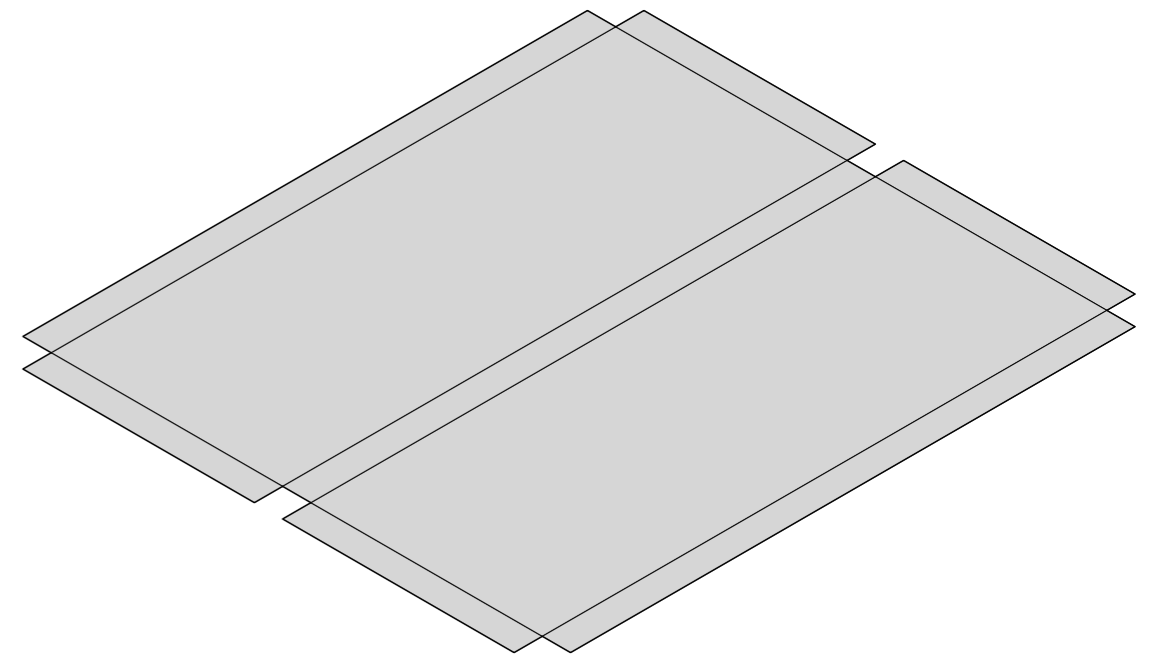

DE Kartonverpackung unterlegen
EN Underlay cardboard packaging

05

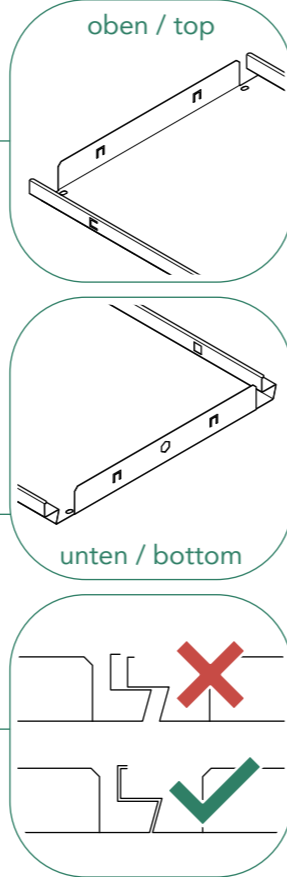
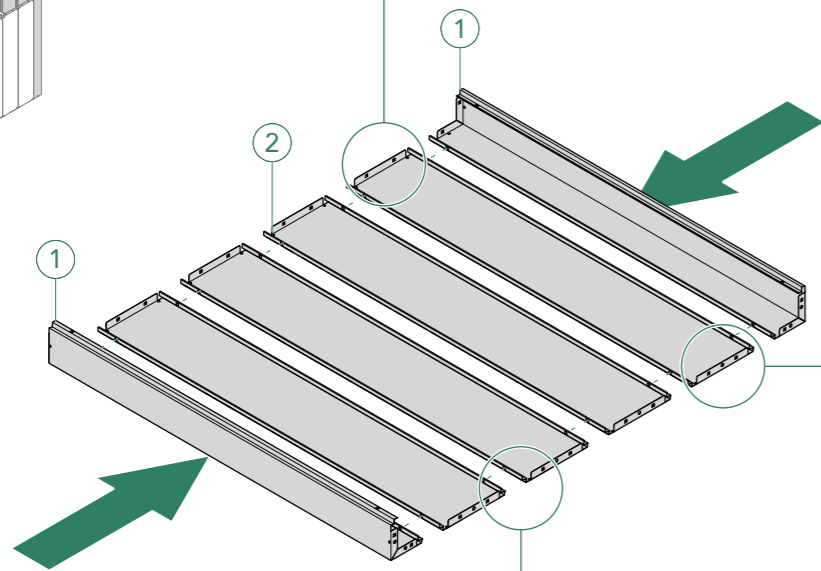
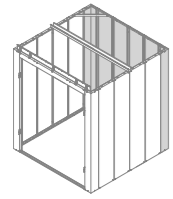

06

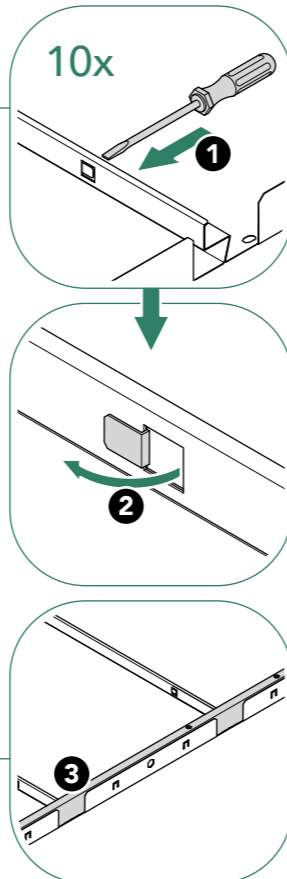
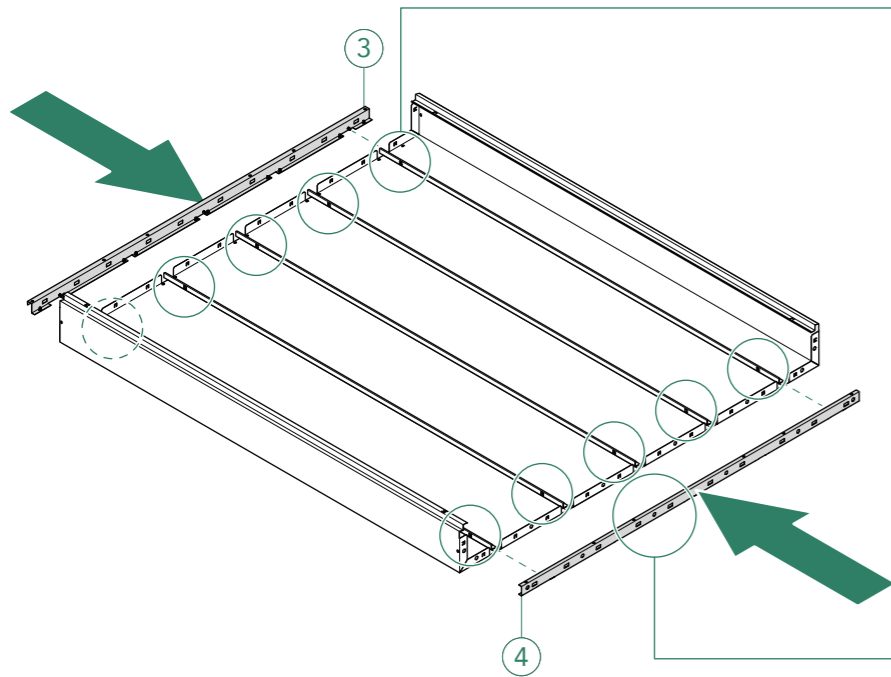

07

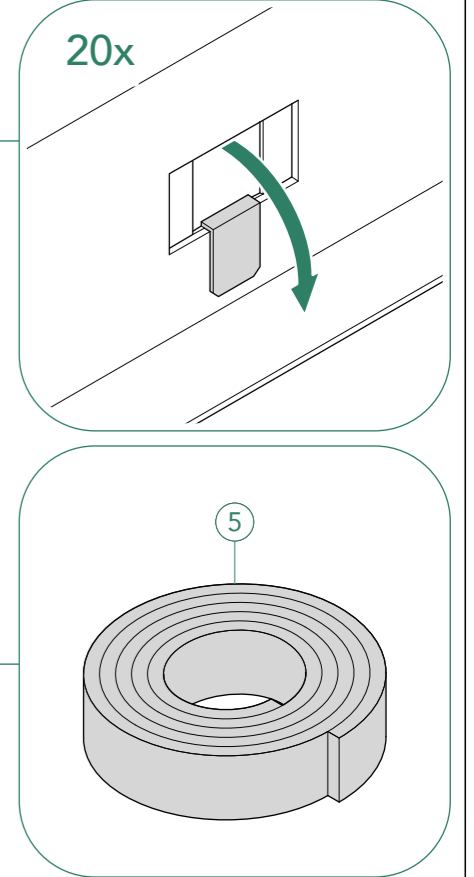
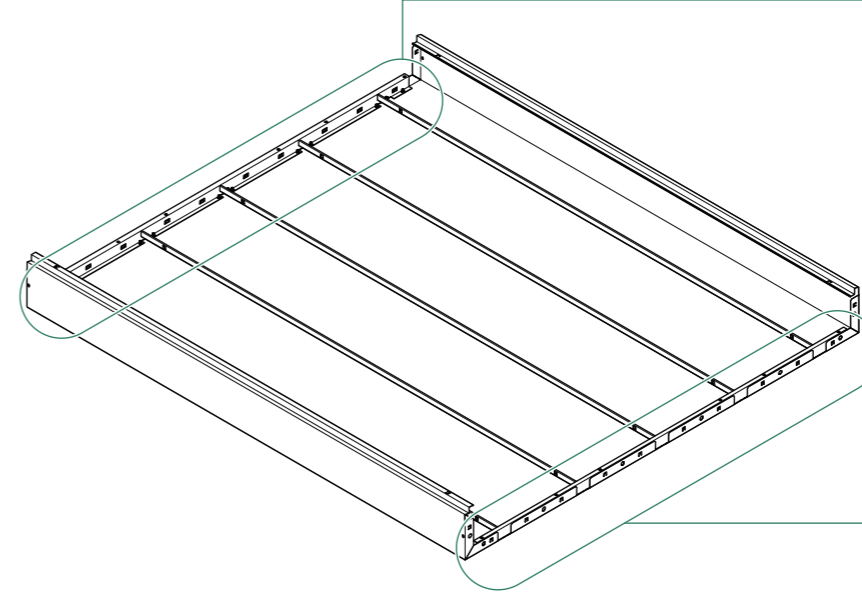

08

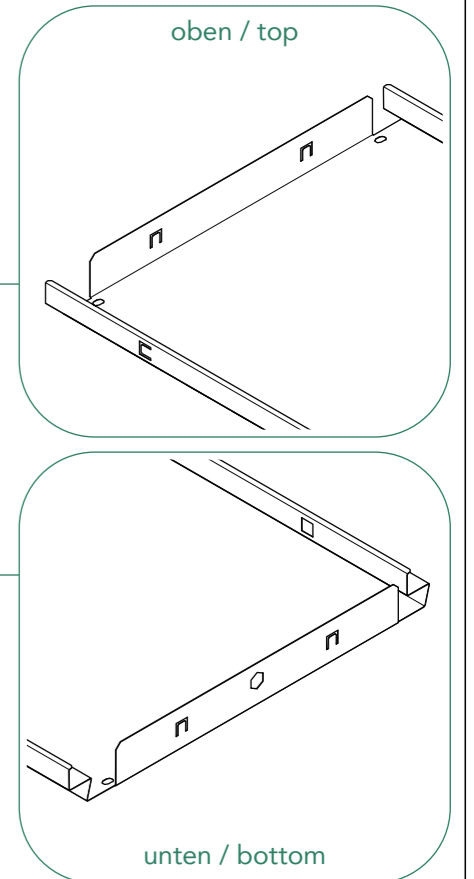
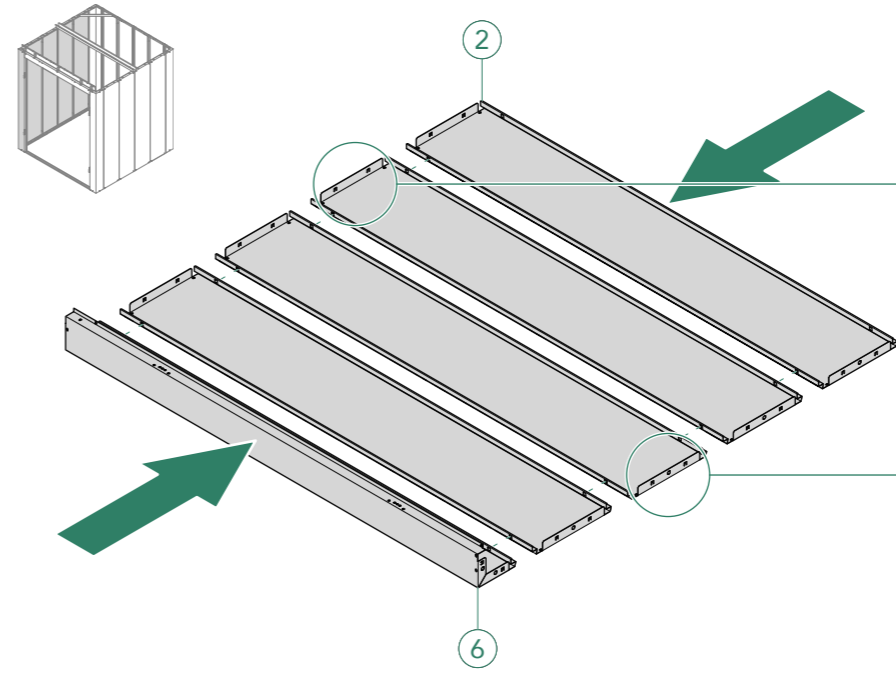

09

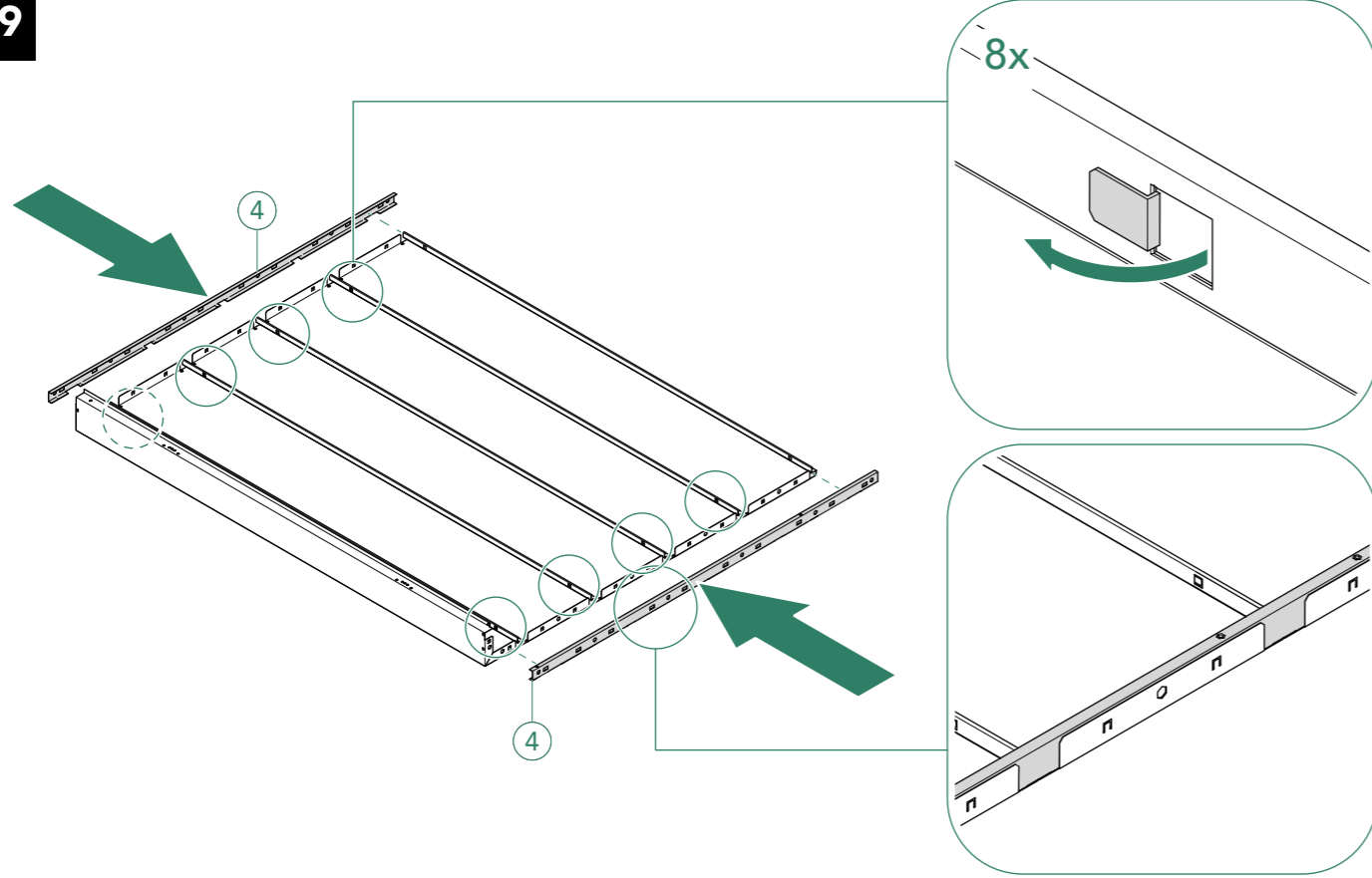

10

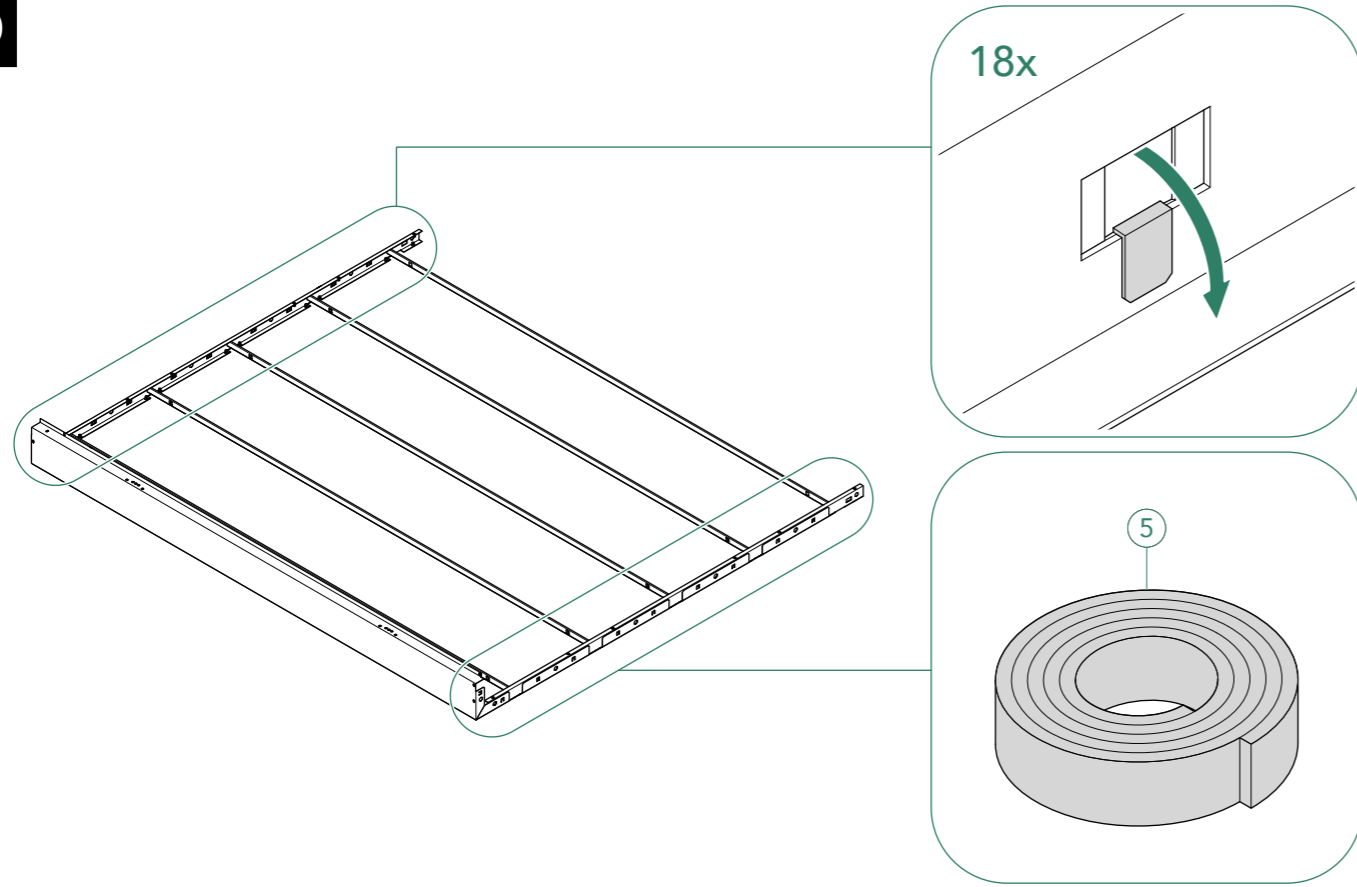

11

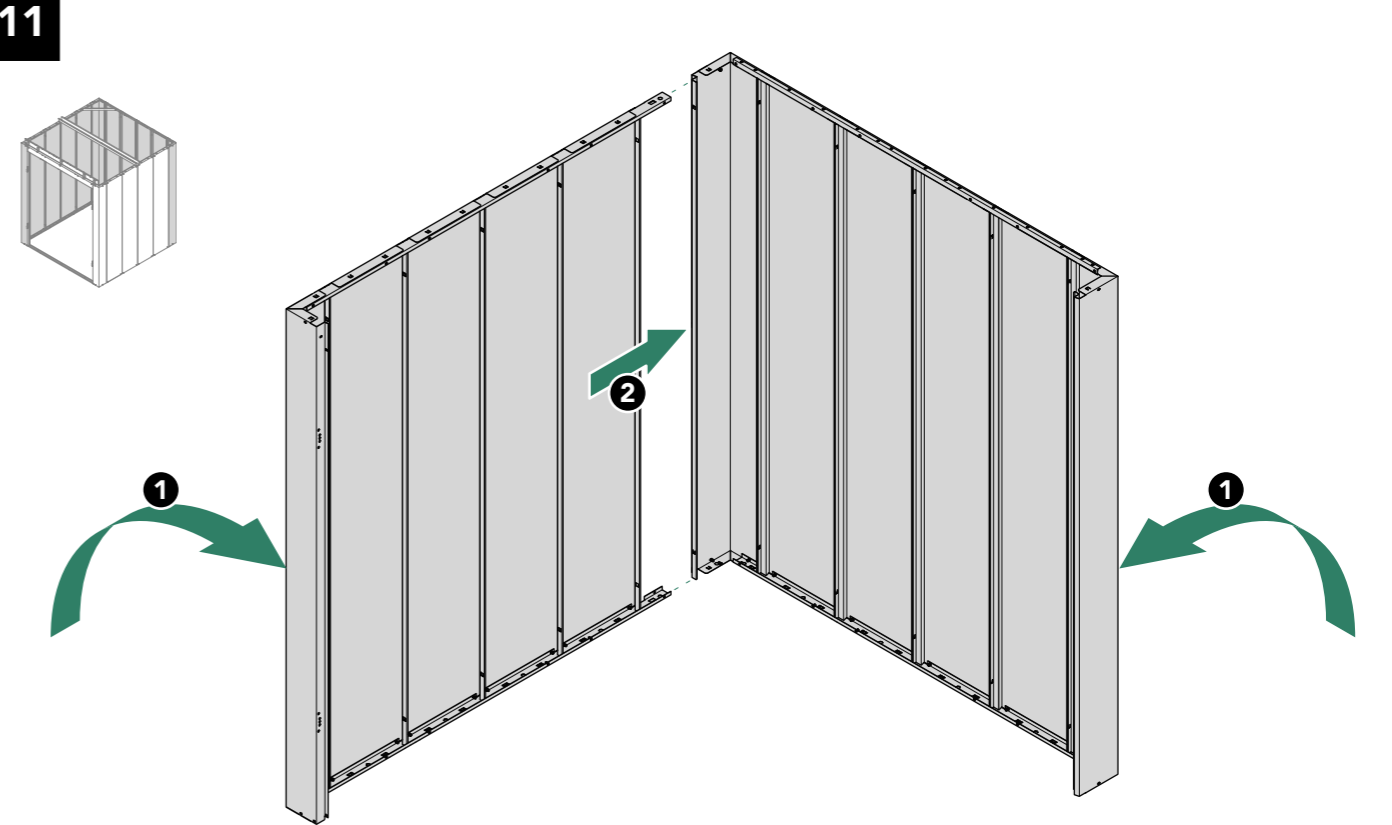

12

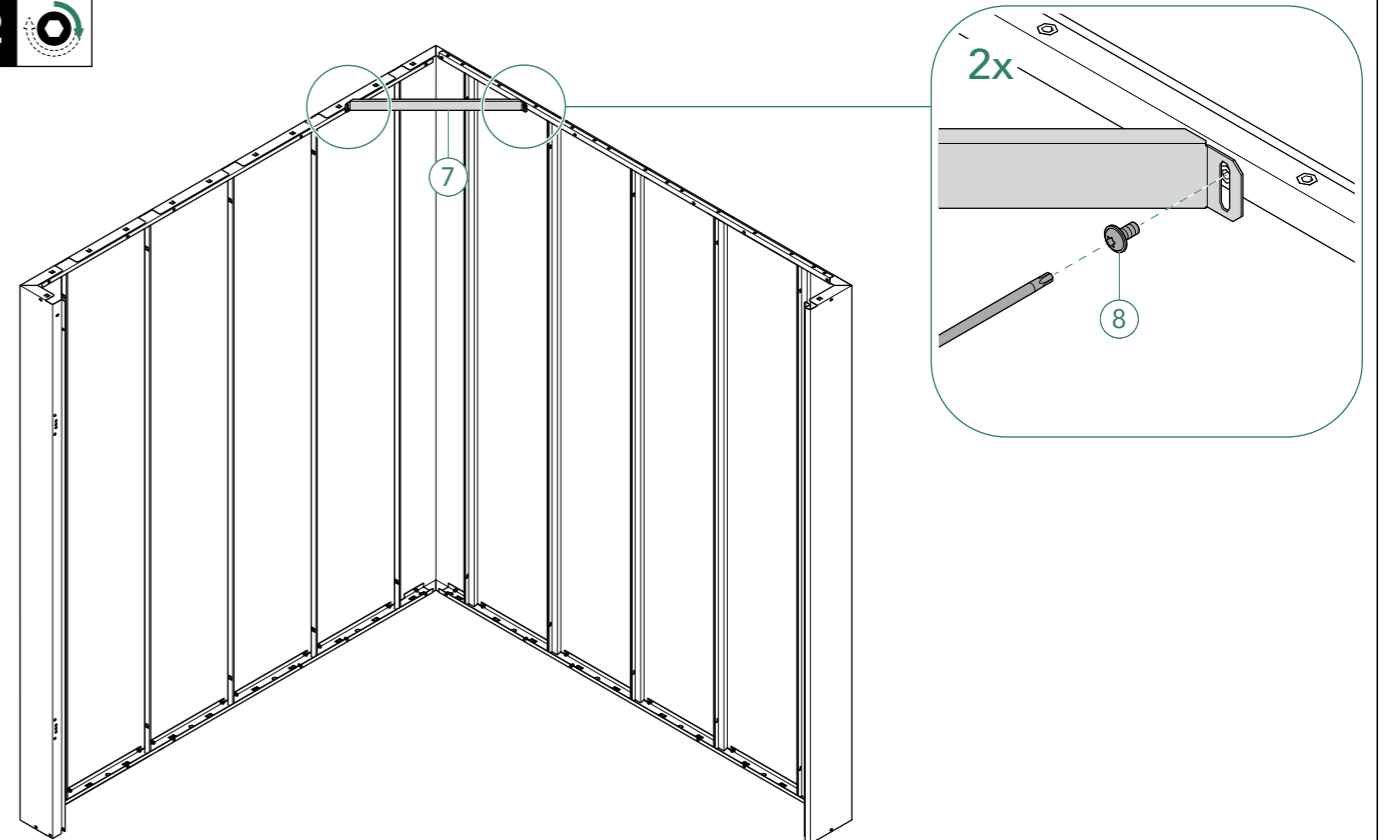

13

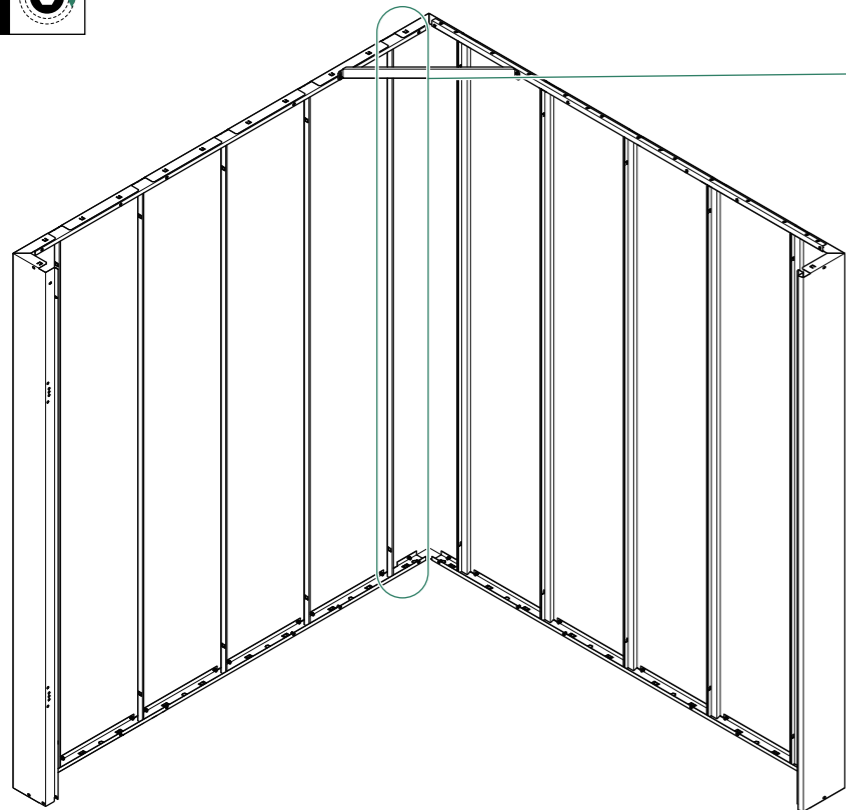

4x

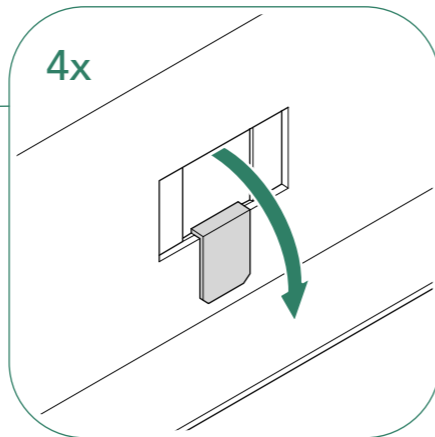

2x

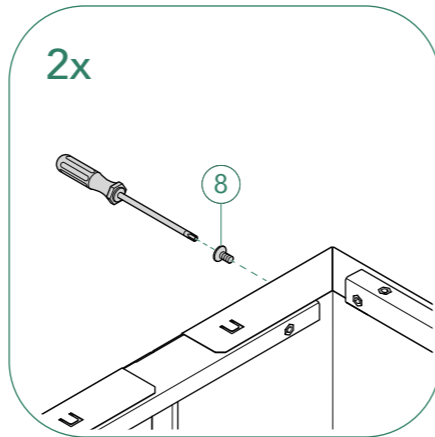

14

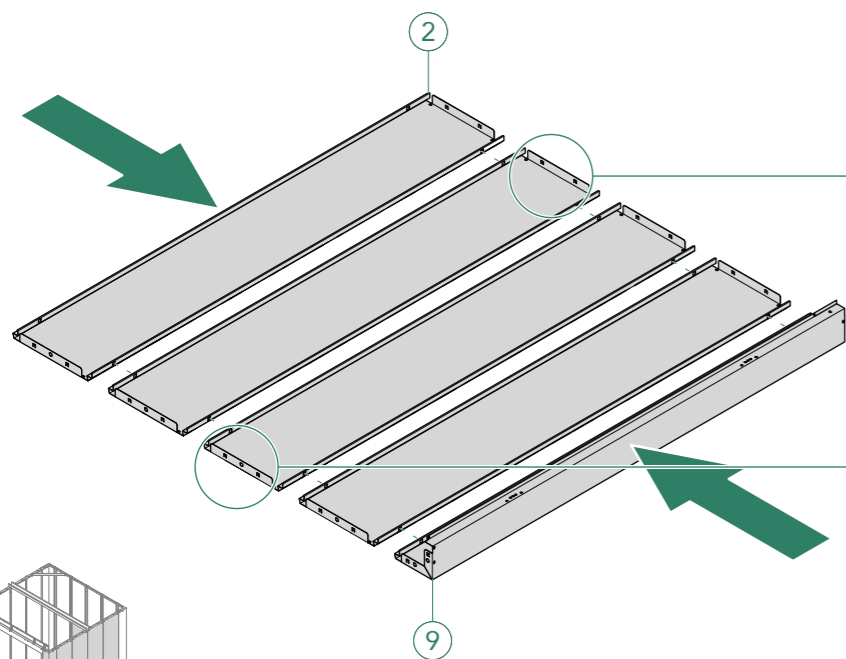

oben / top

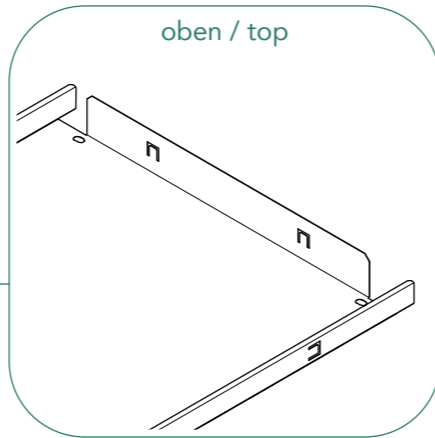

unten / bottom

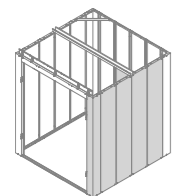
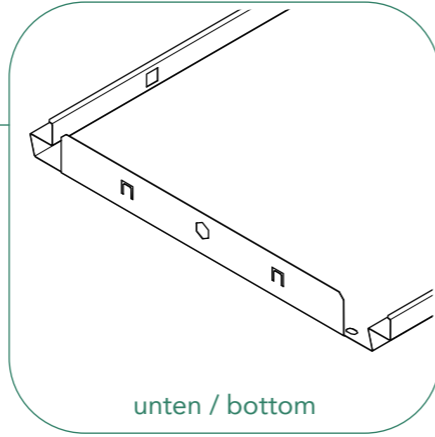

15

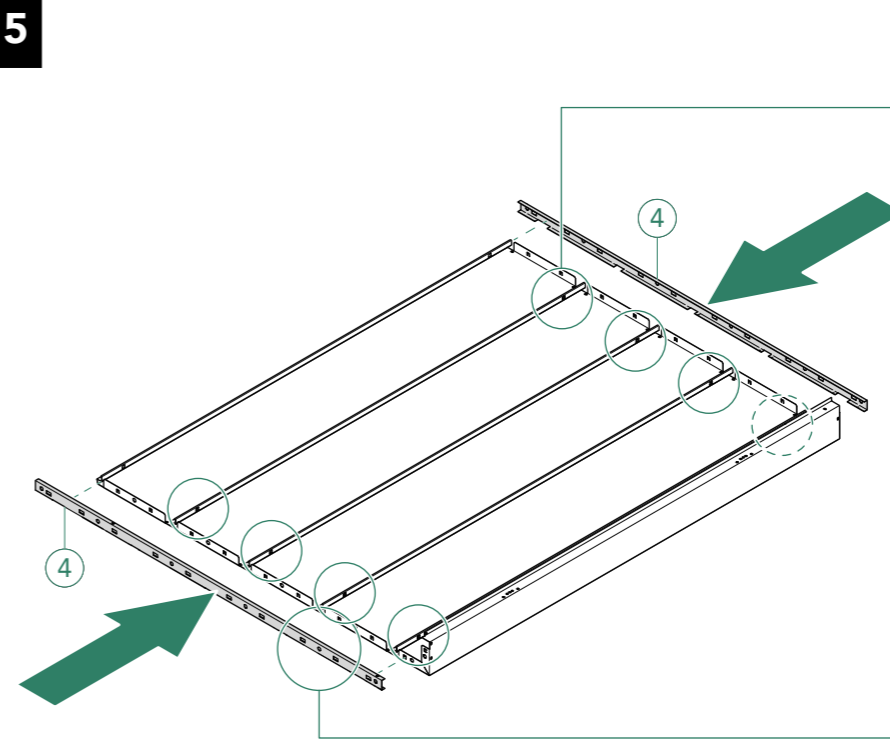

8x

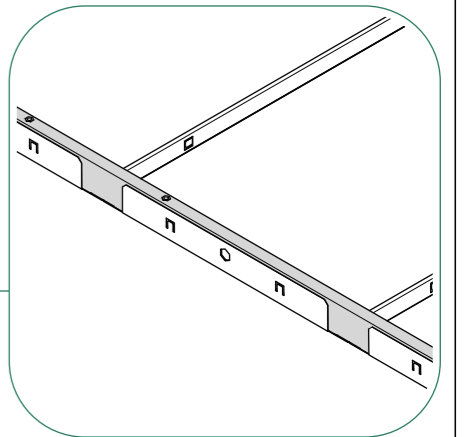
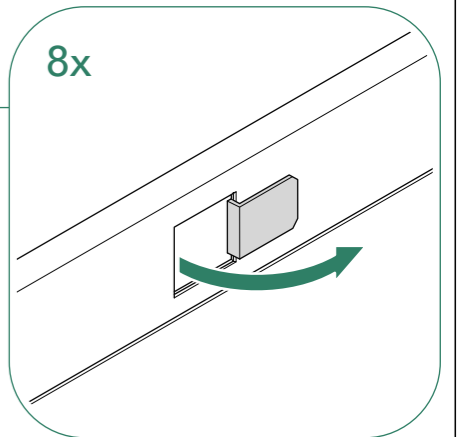

16

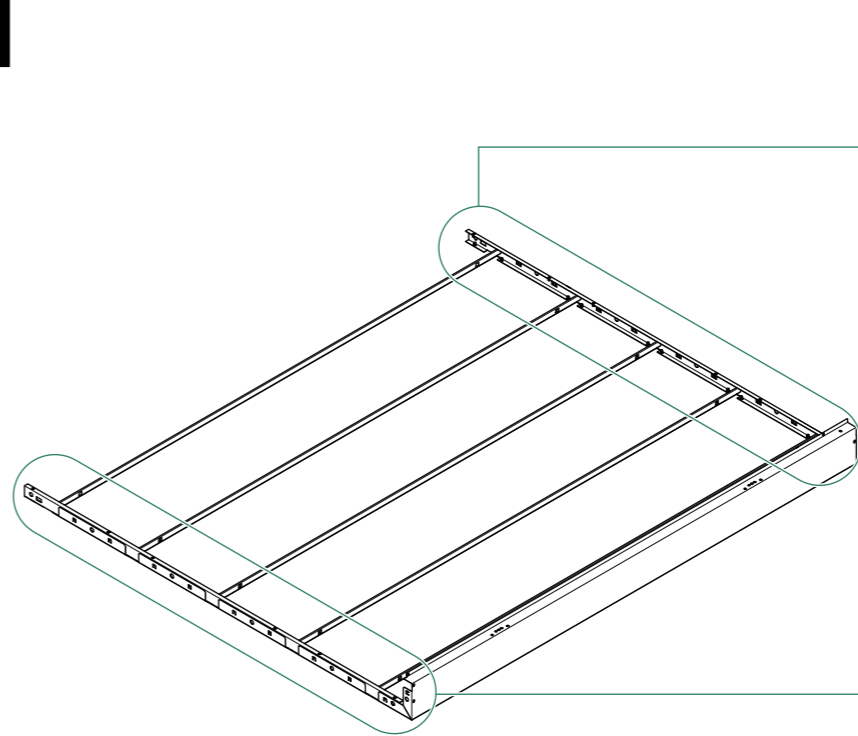

18x

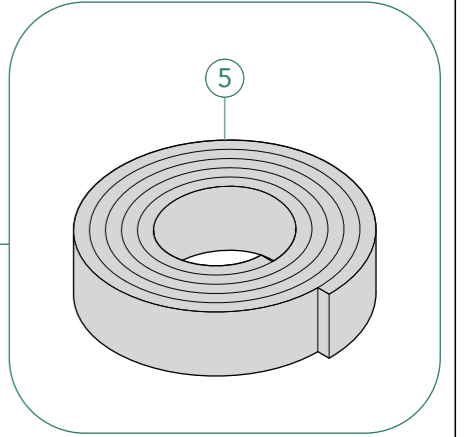
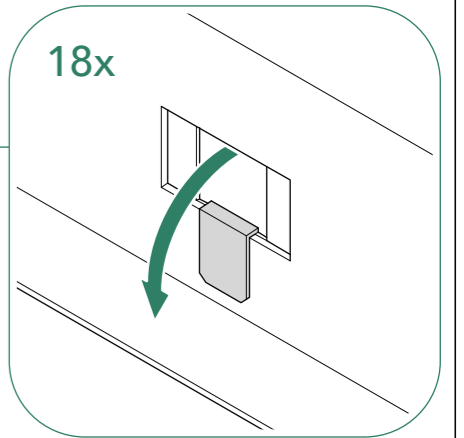

17

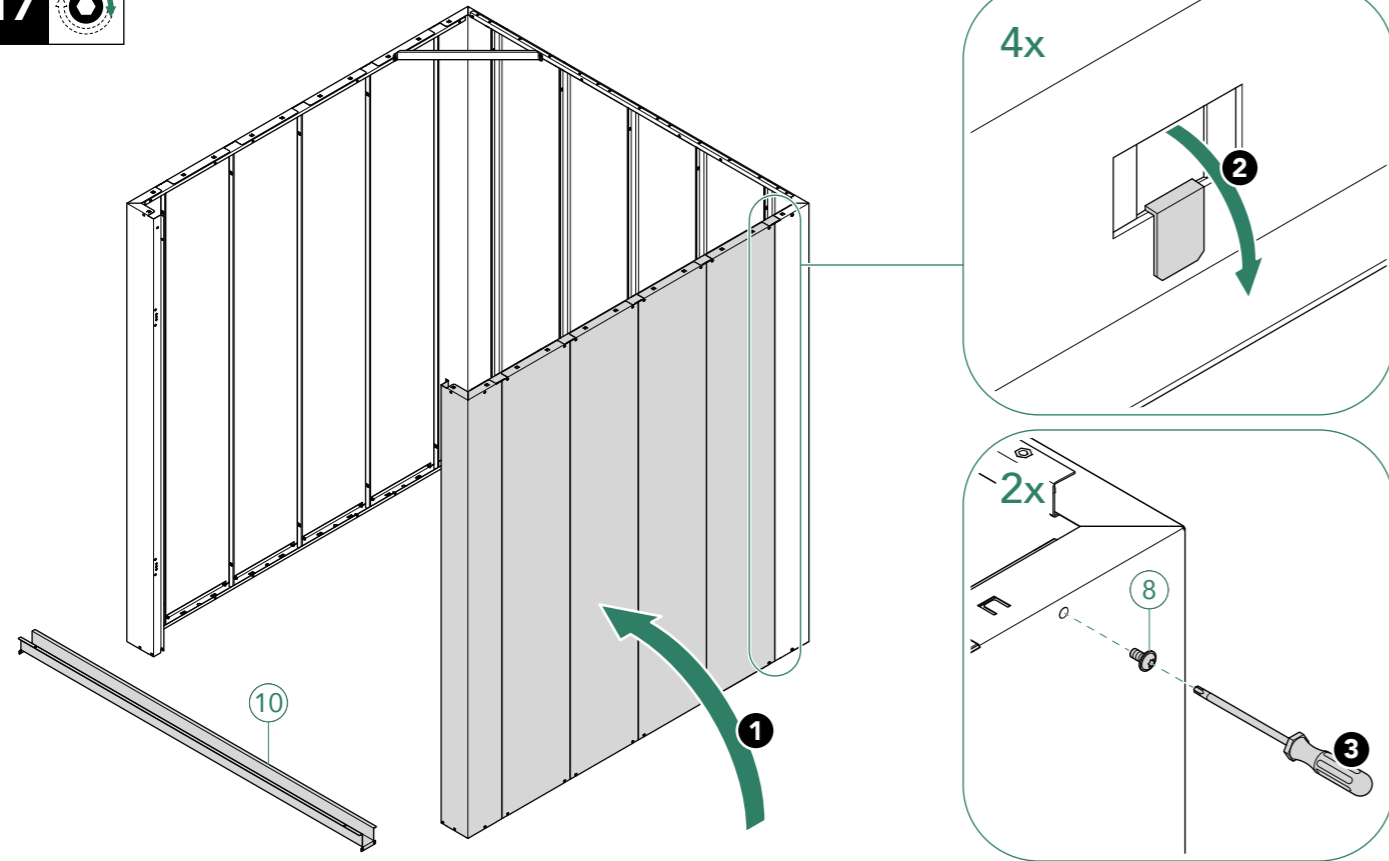

18

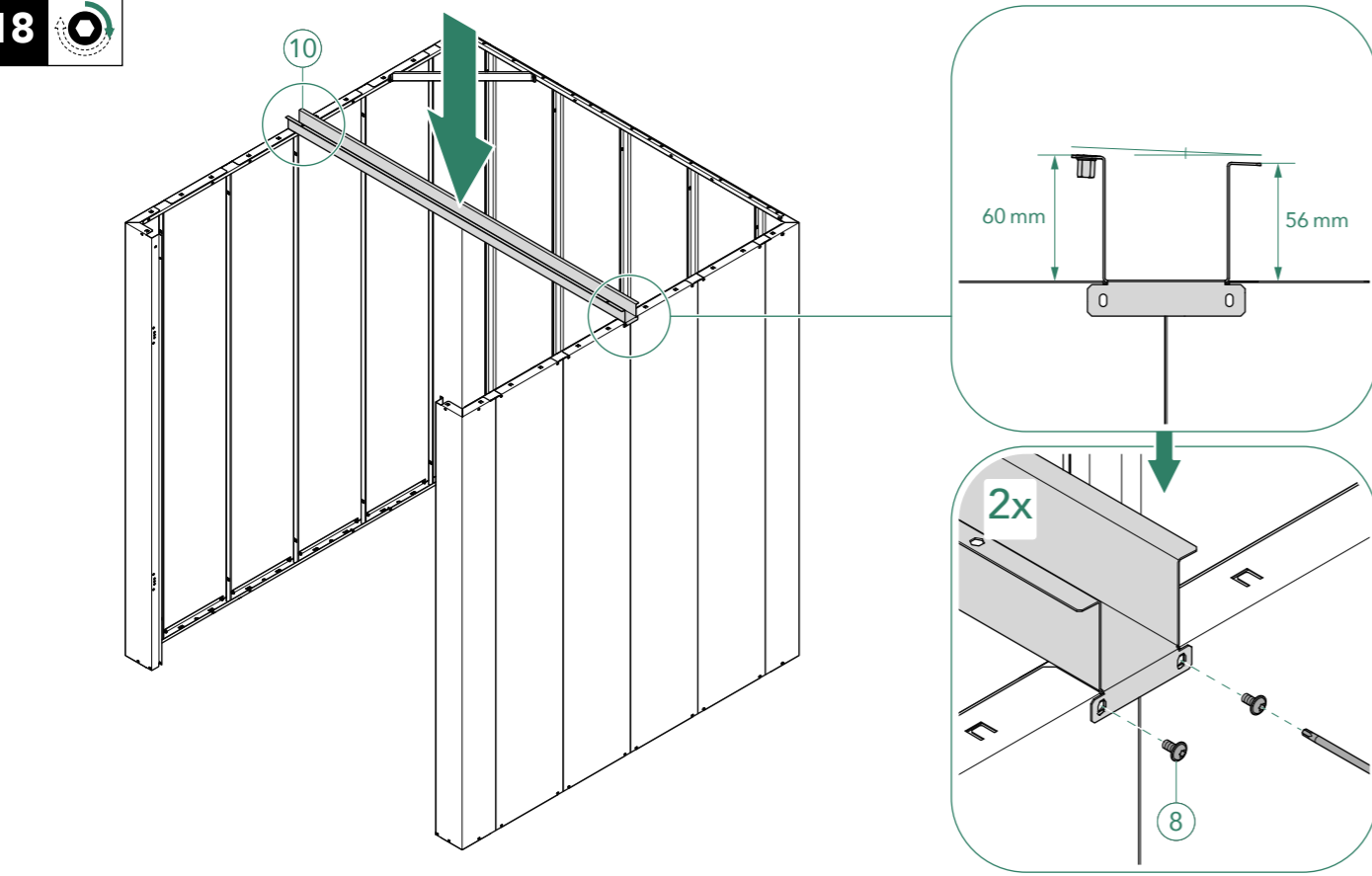

19

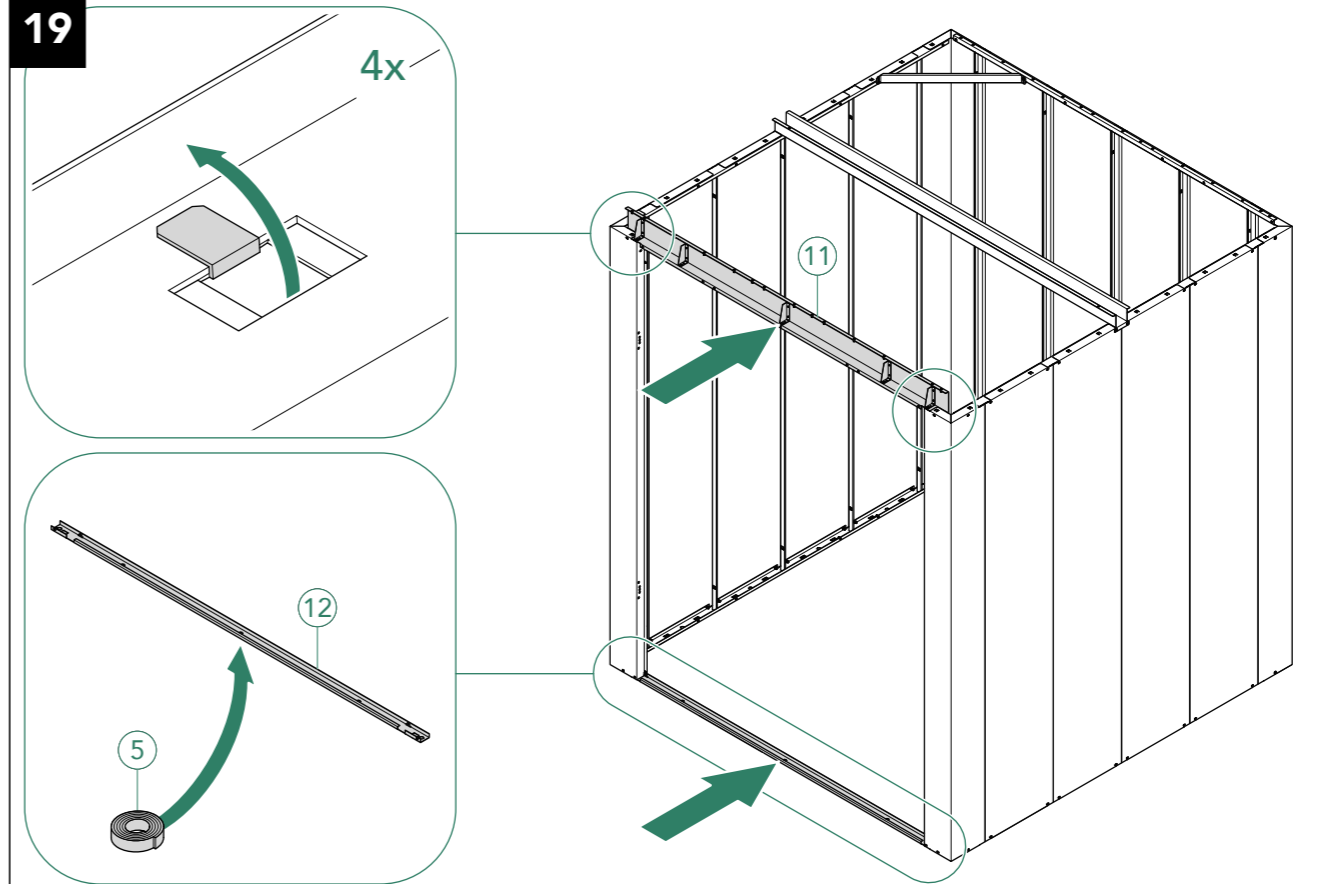

20

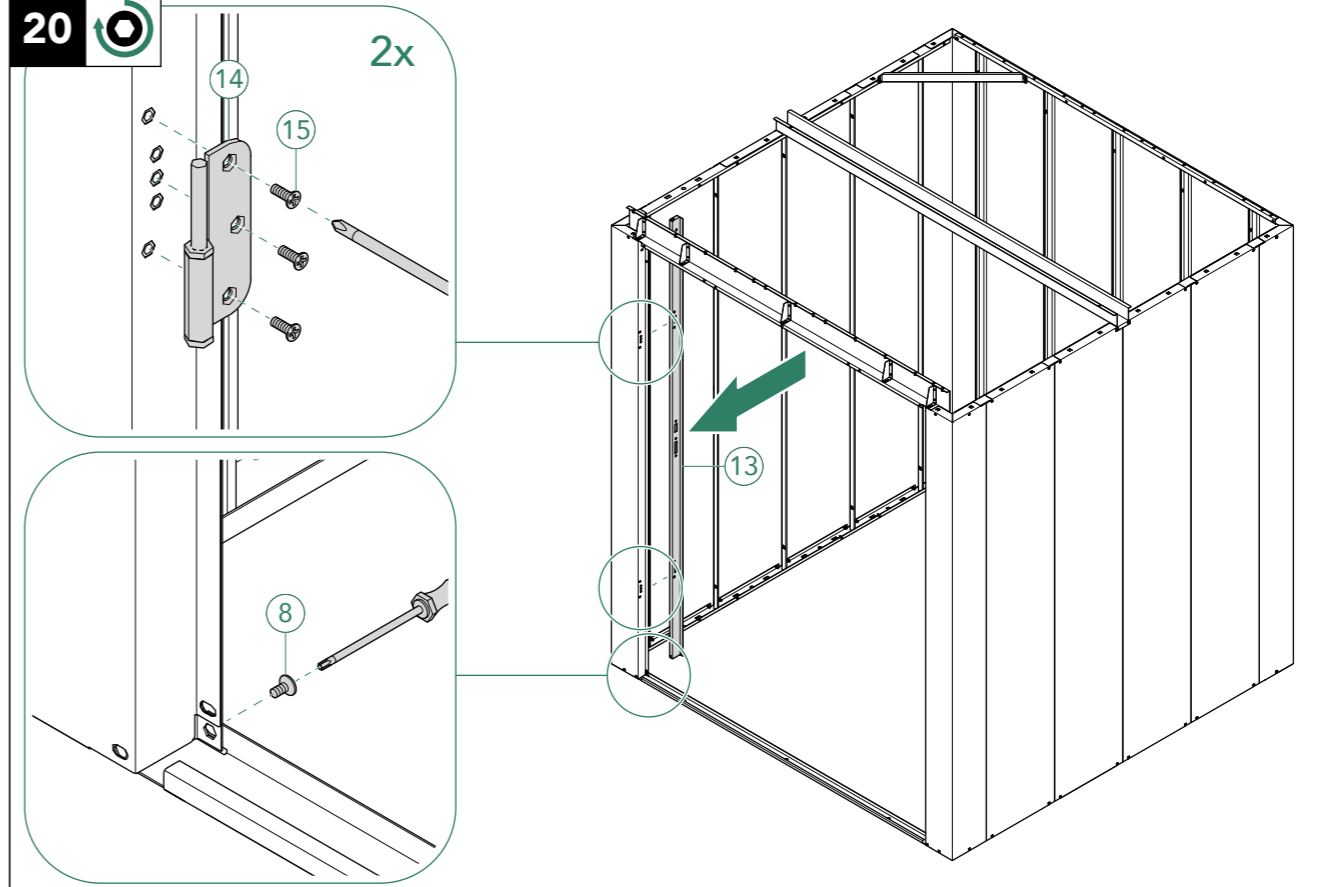

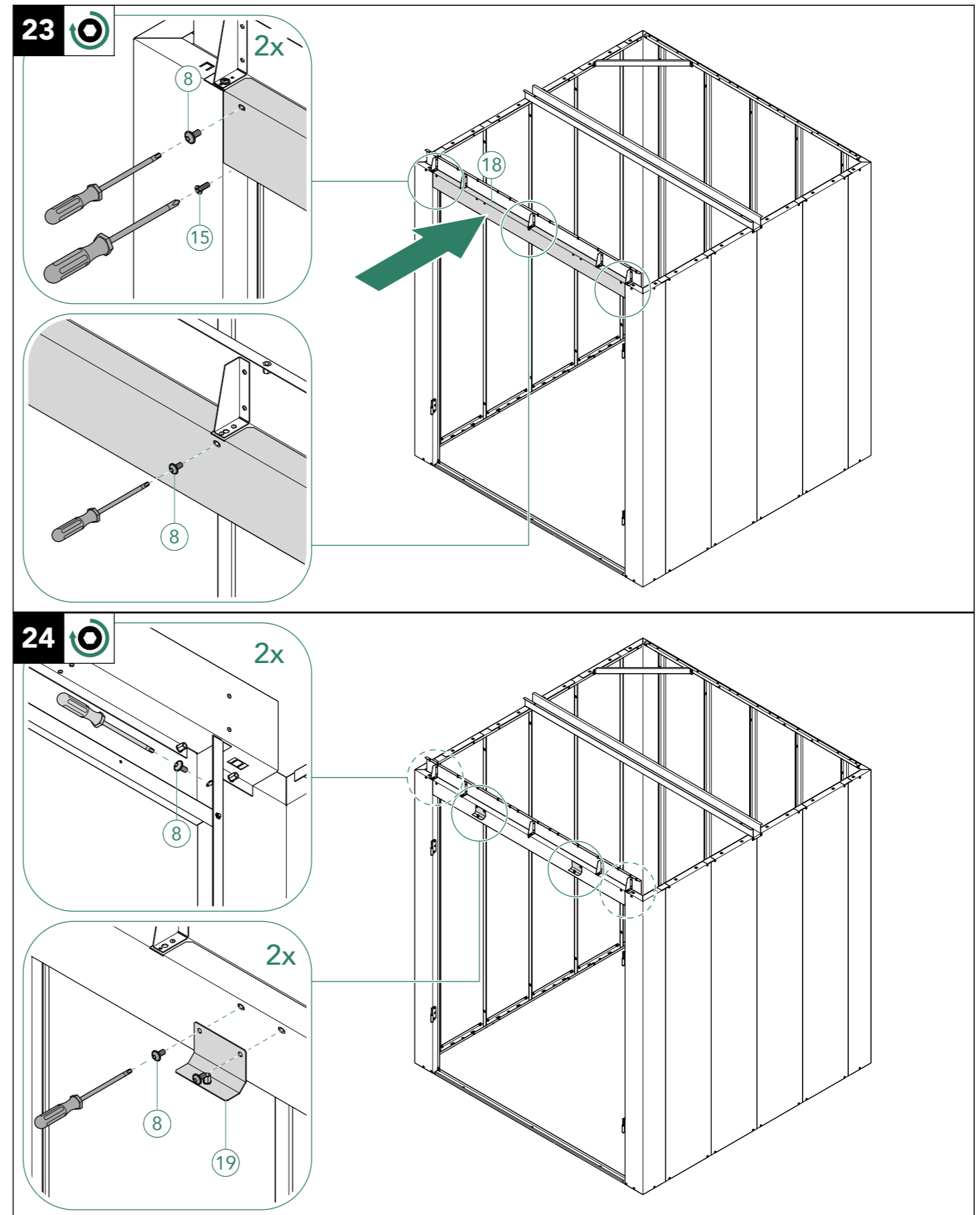
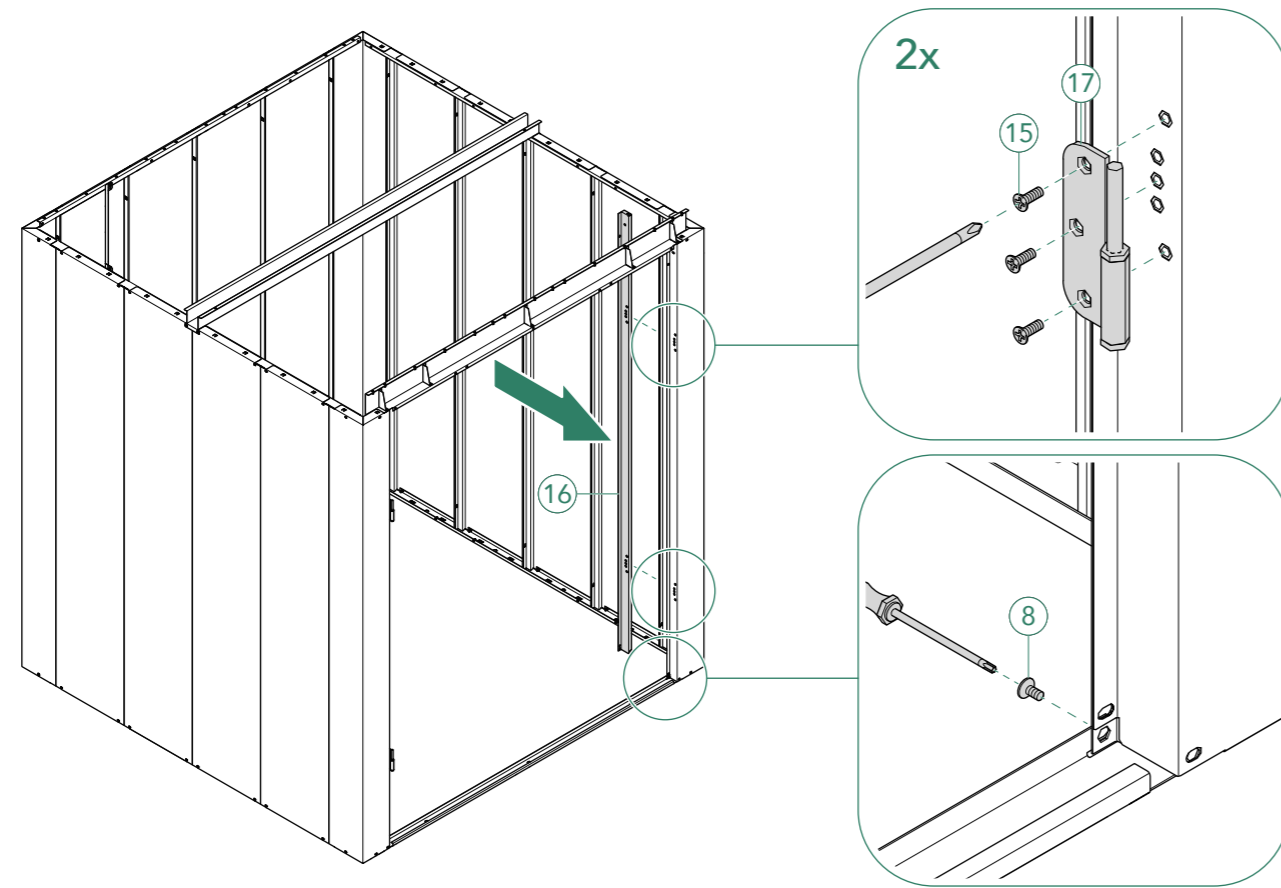

25

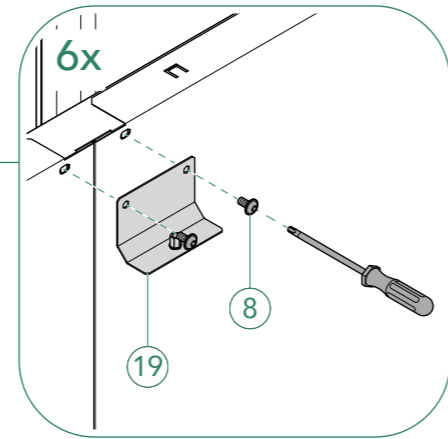
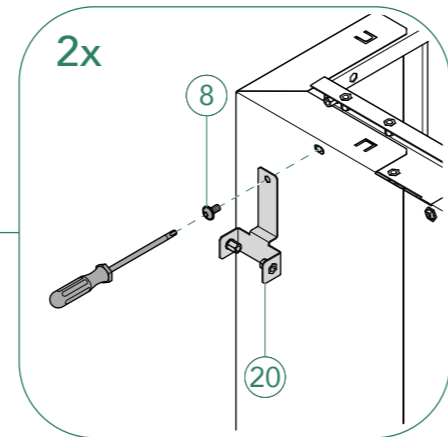
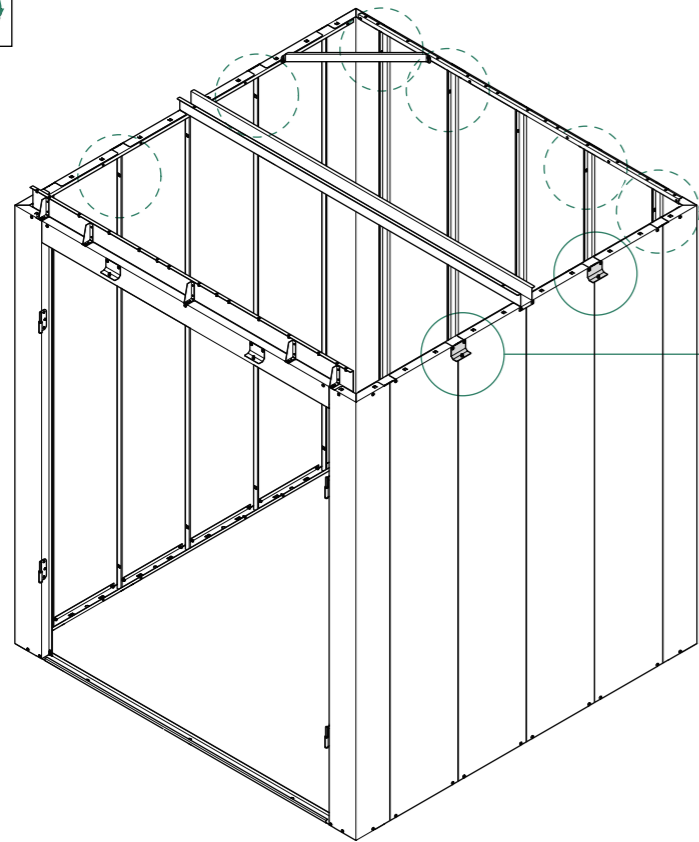

26

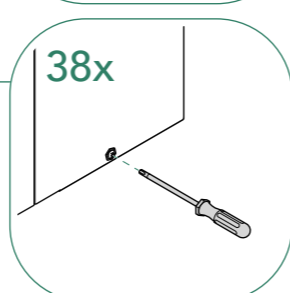
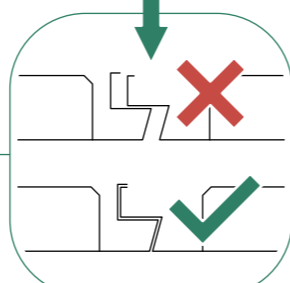
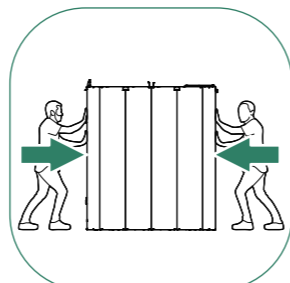
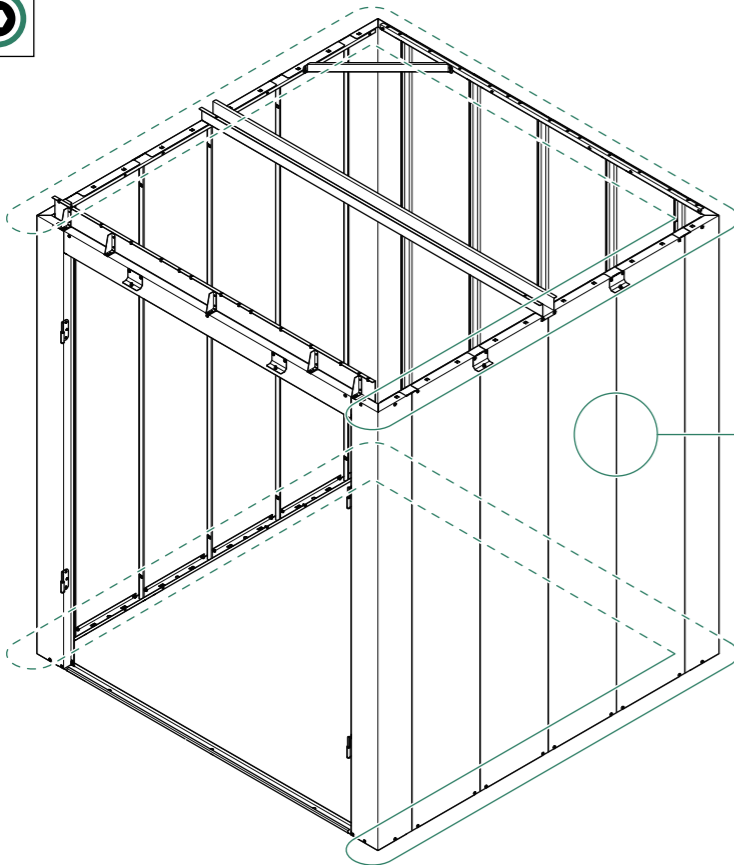

27

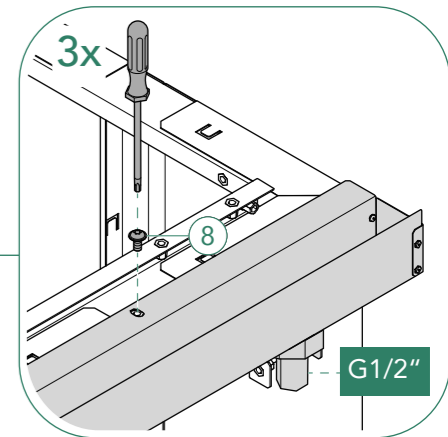
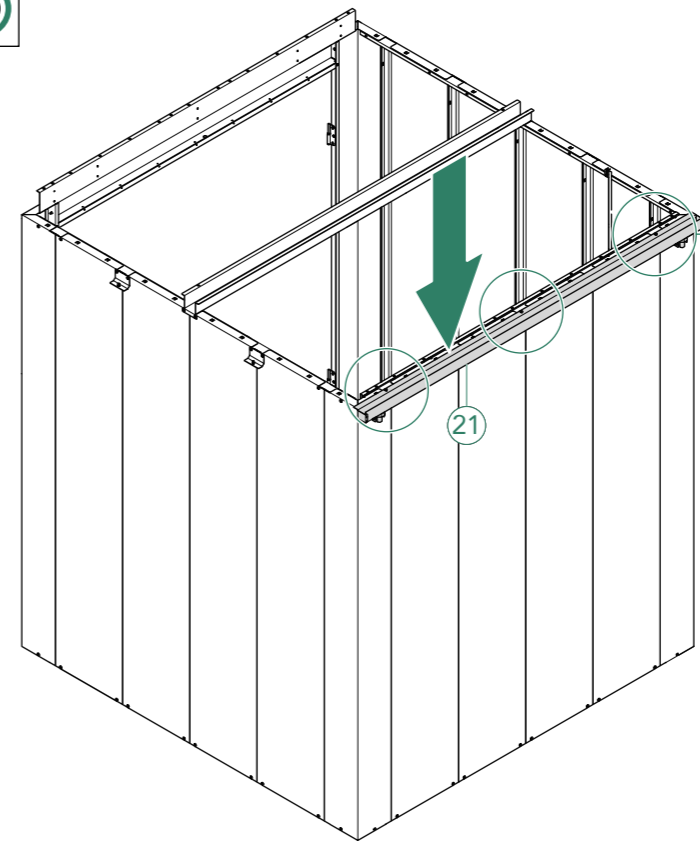

28

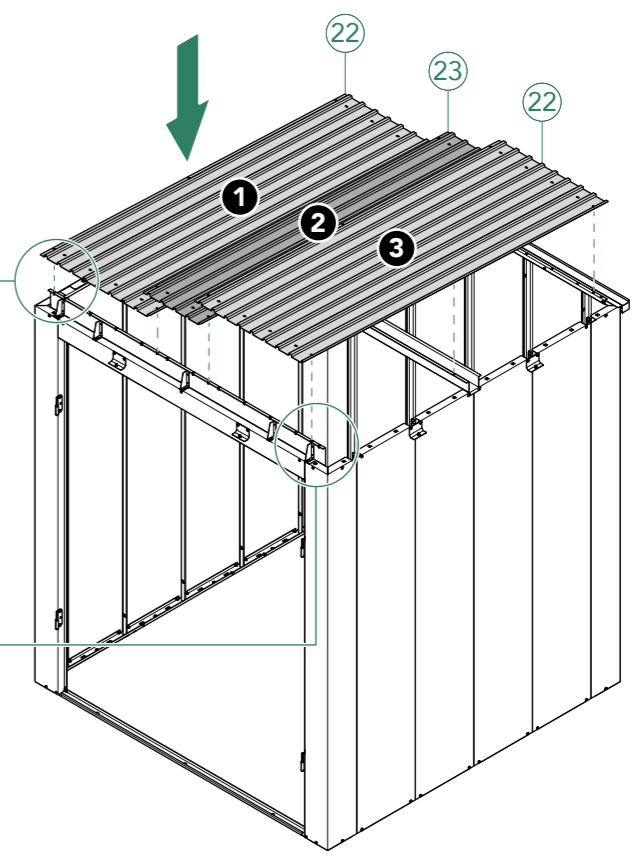
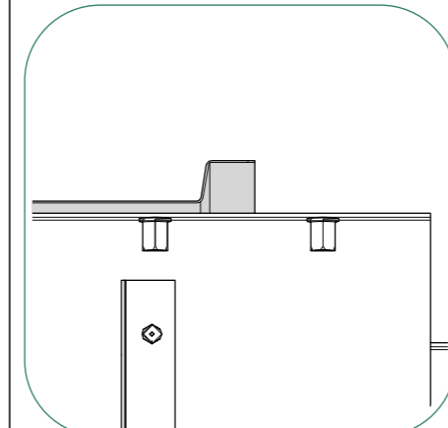
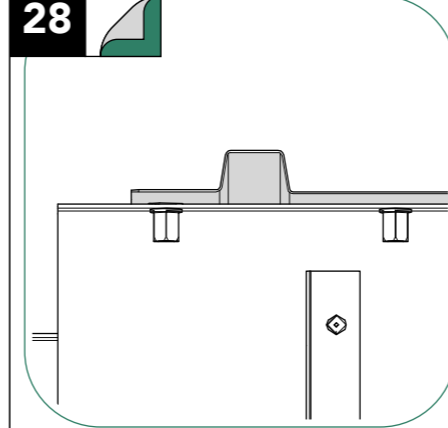

29

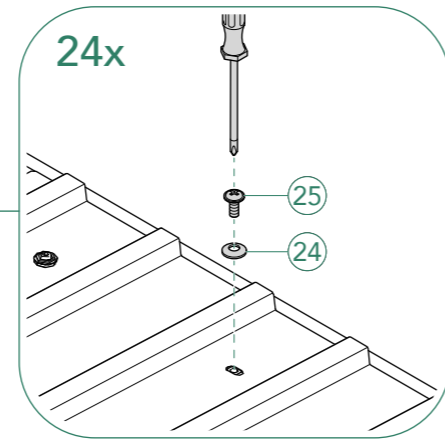
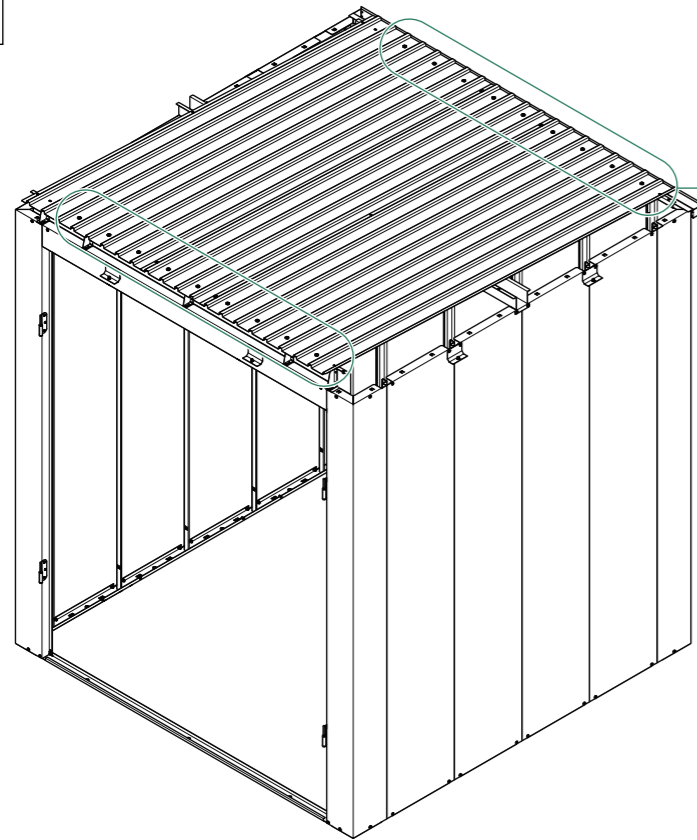

30

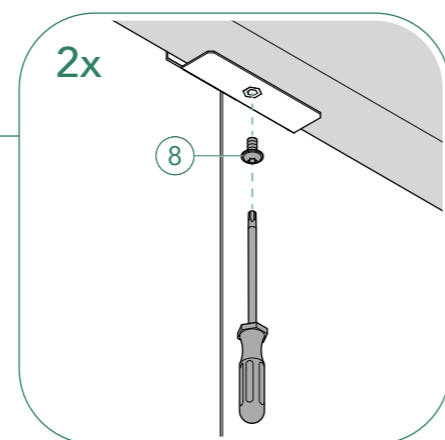
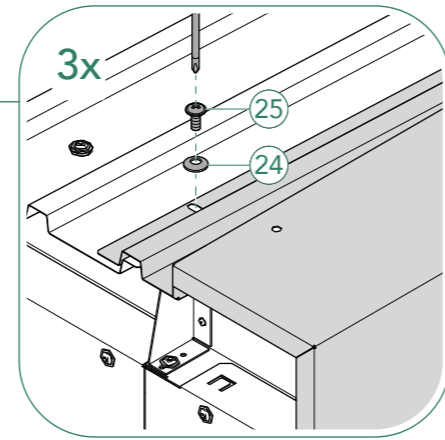
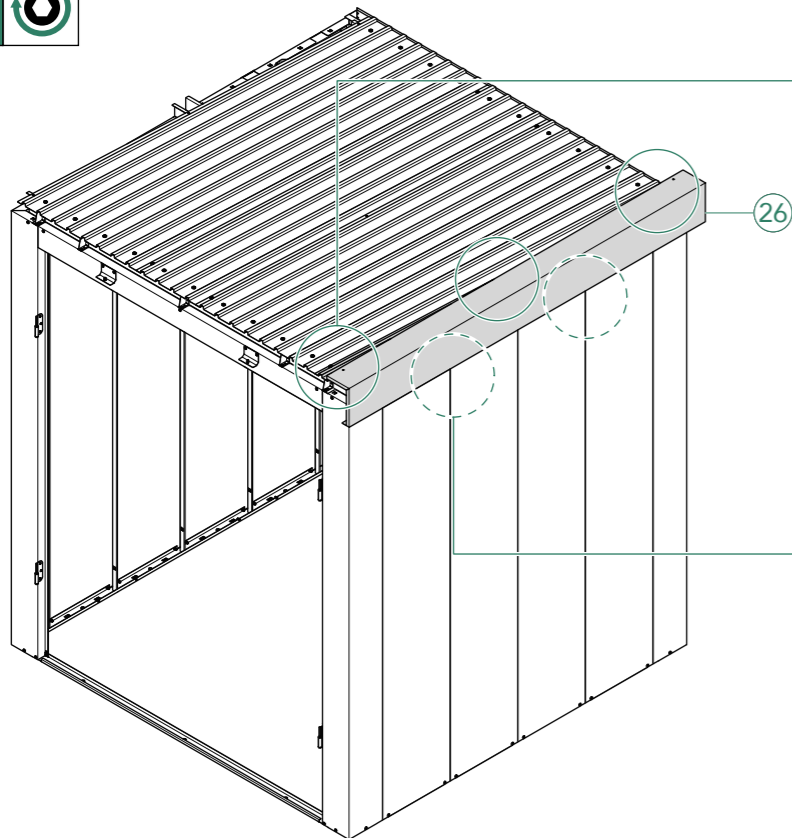

31

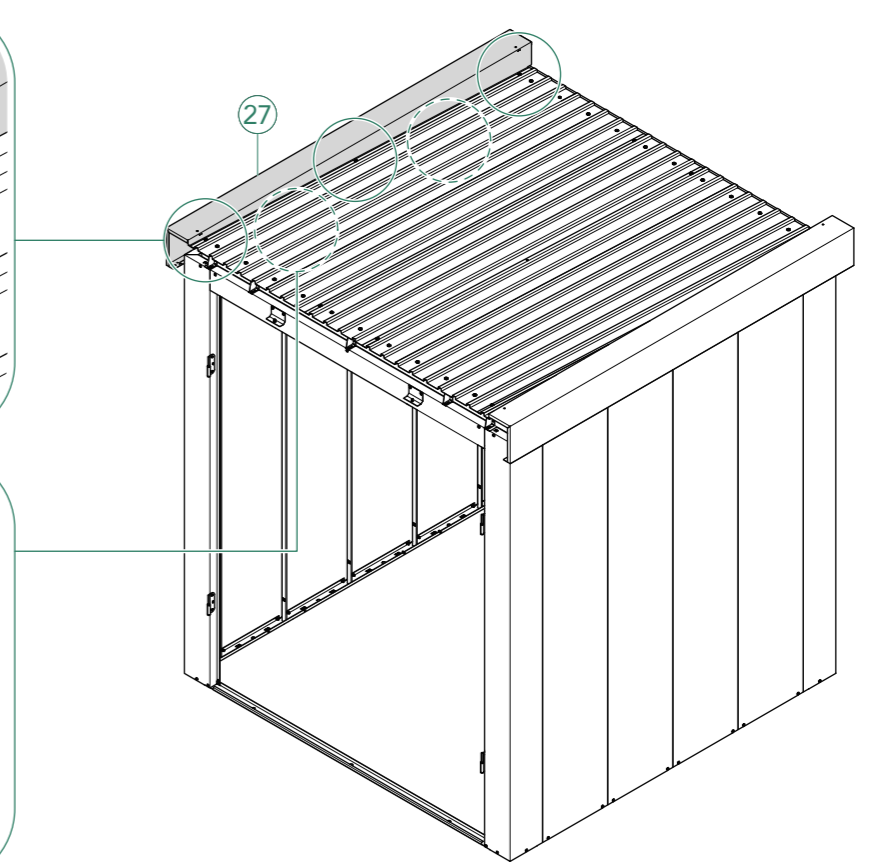
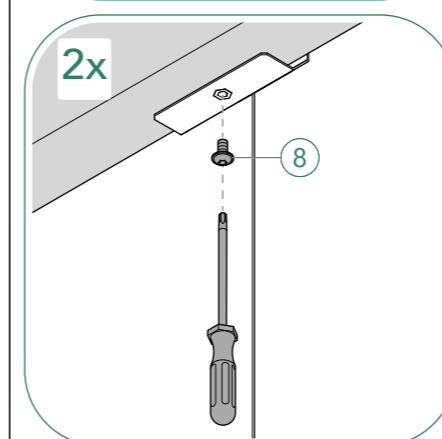
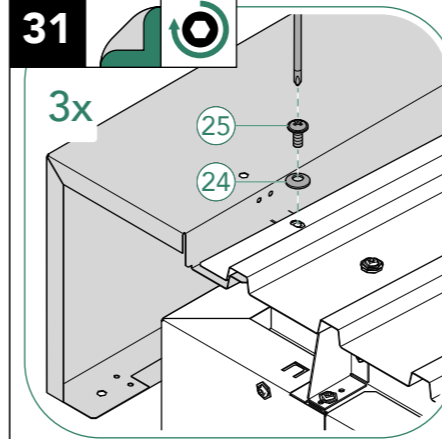

32

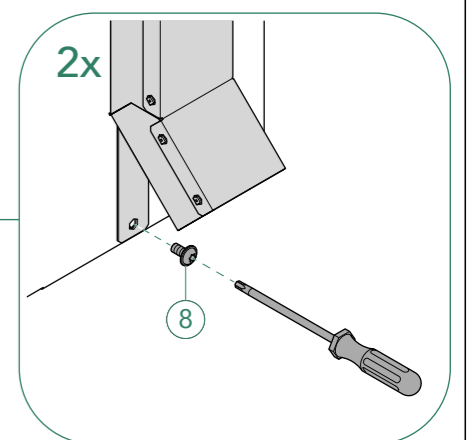
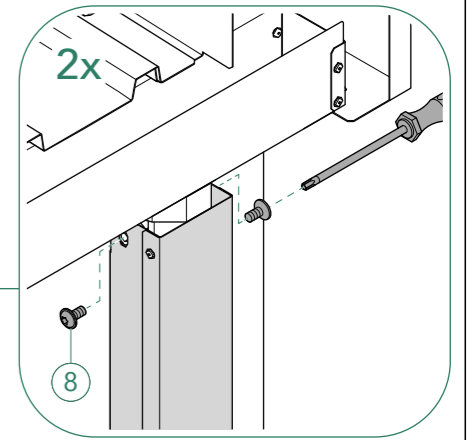
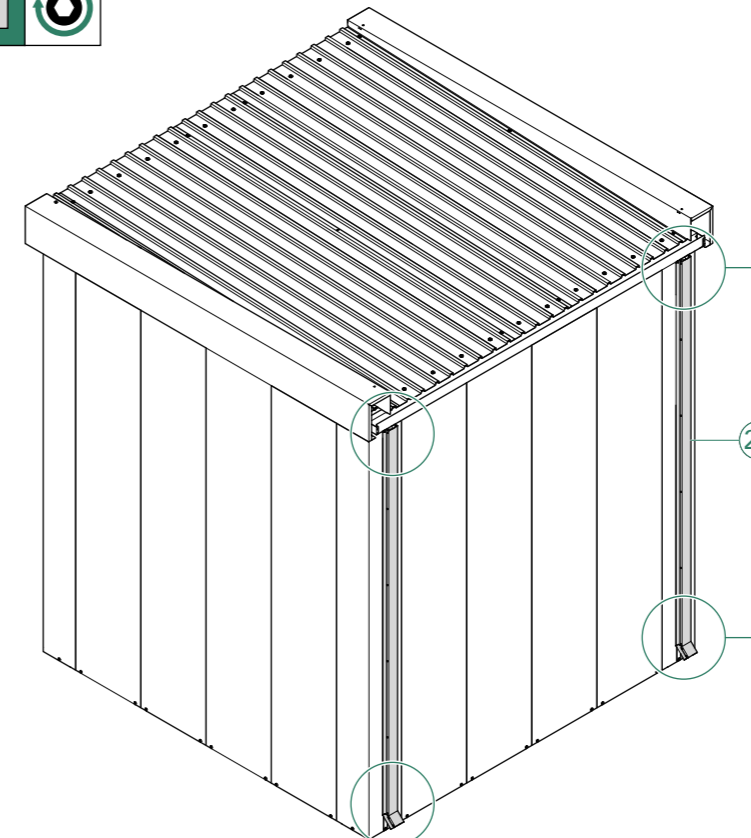

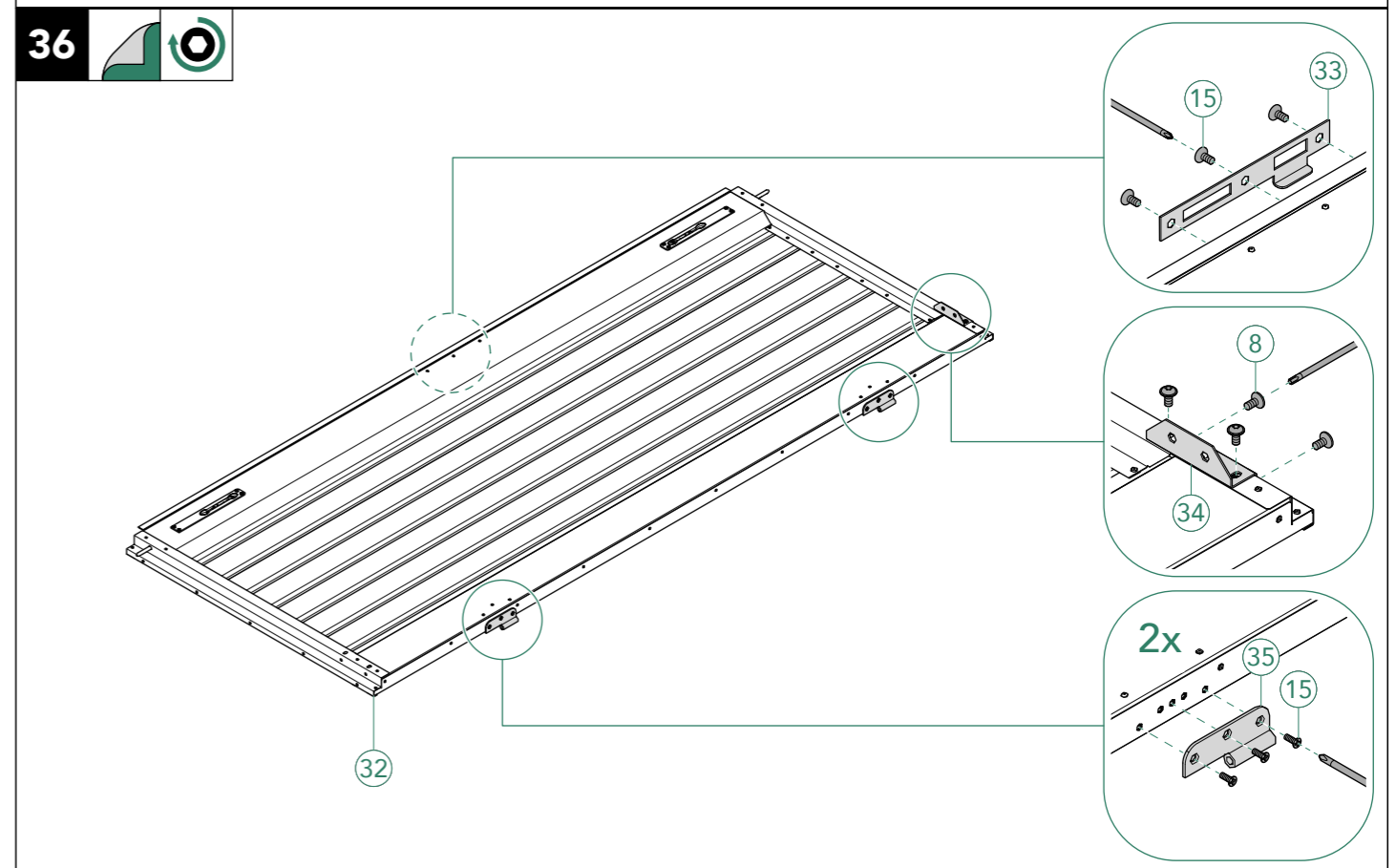
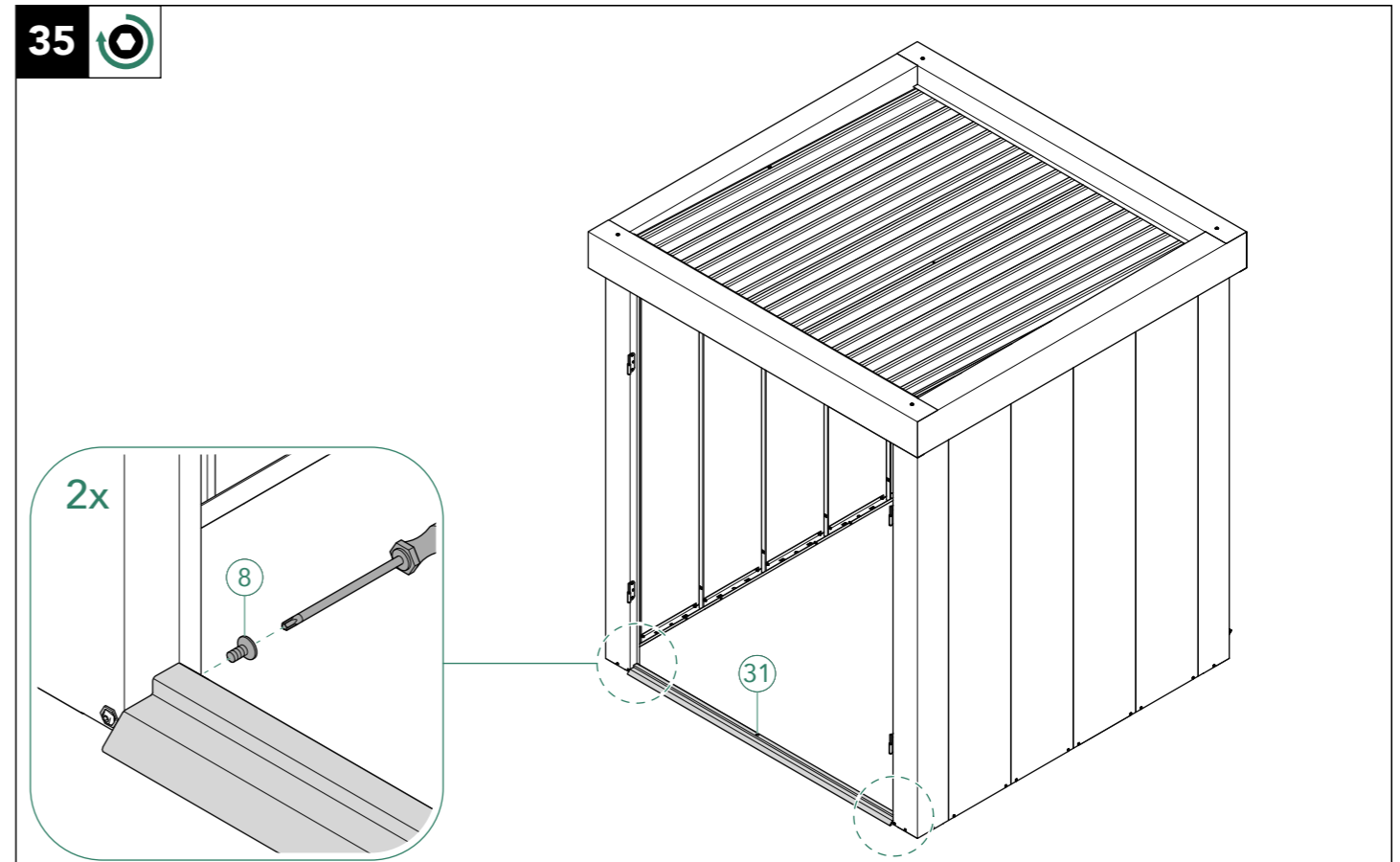
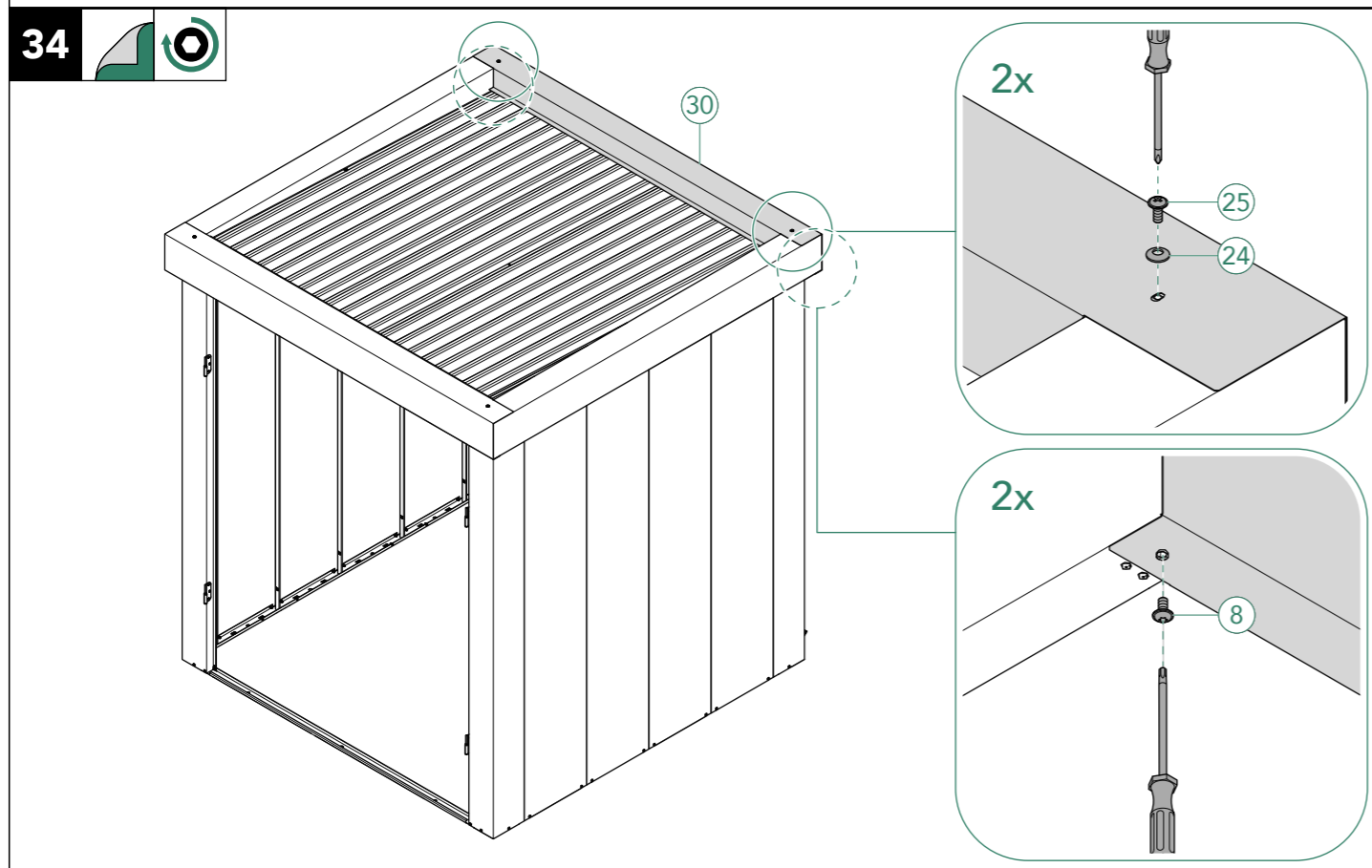
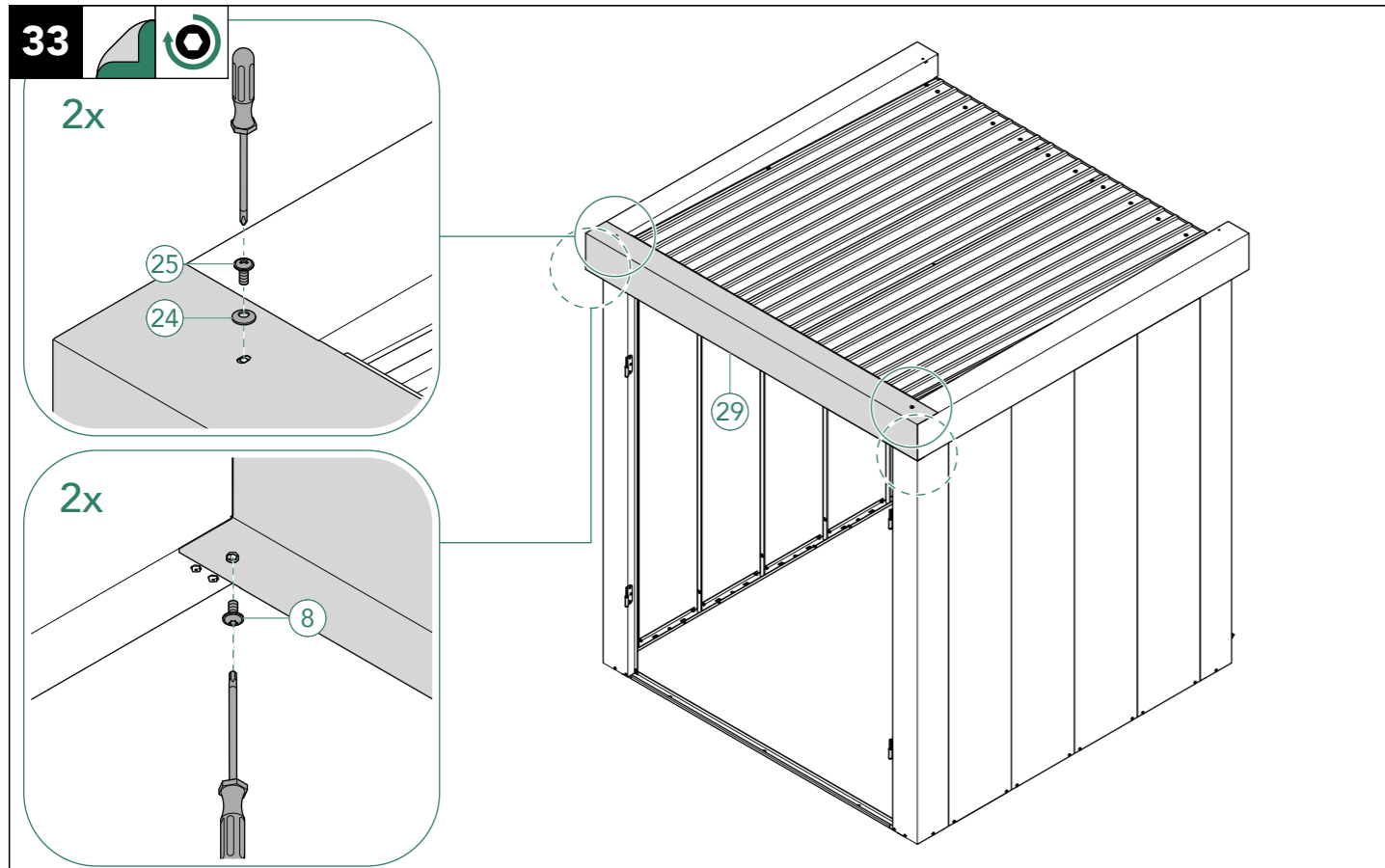

37

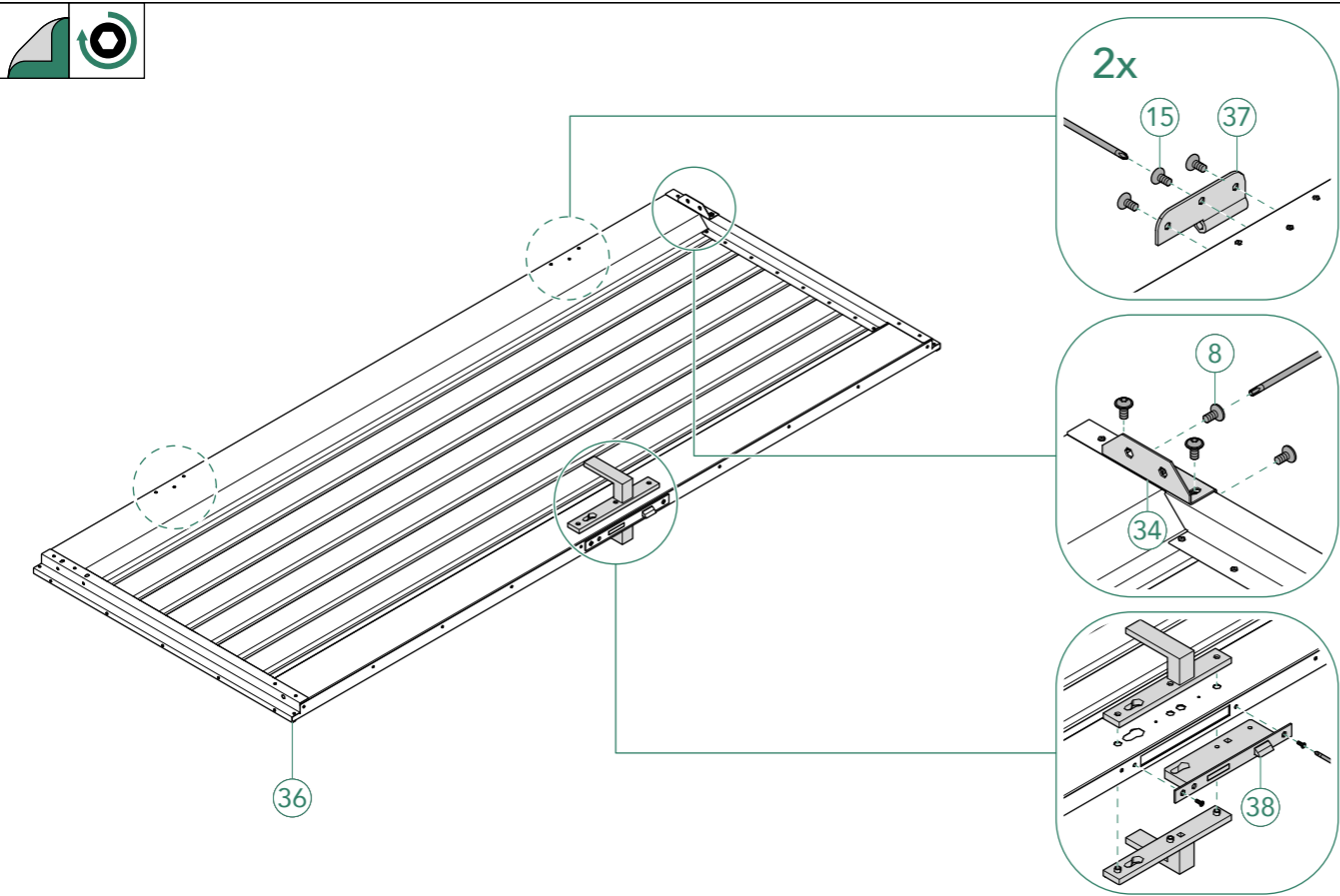

38

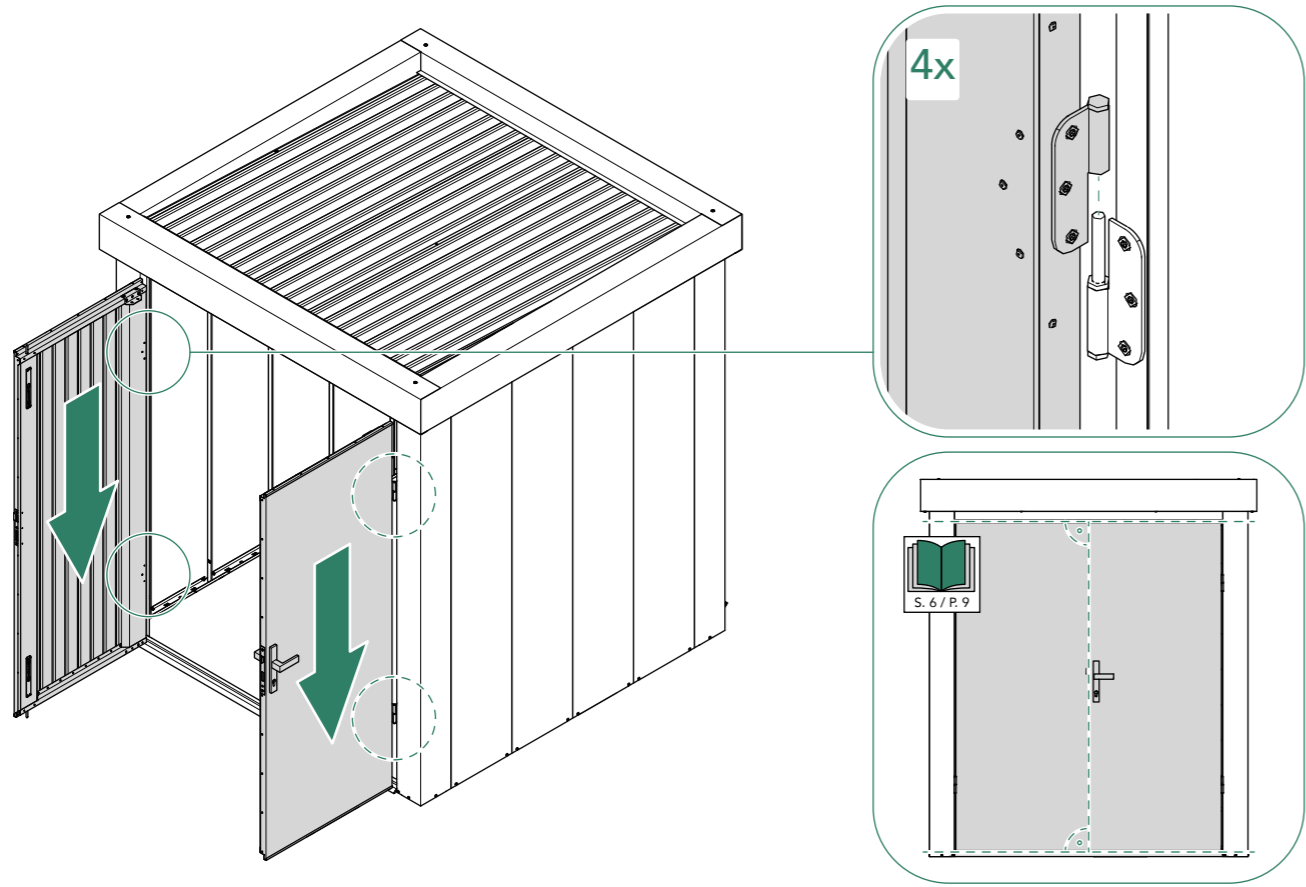

39

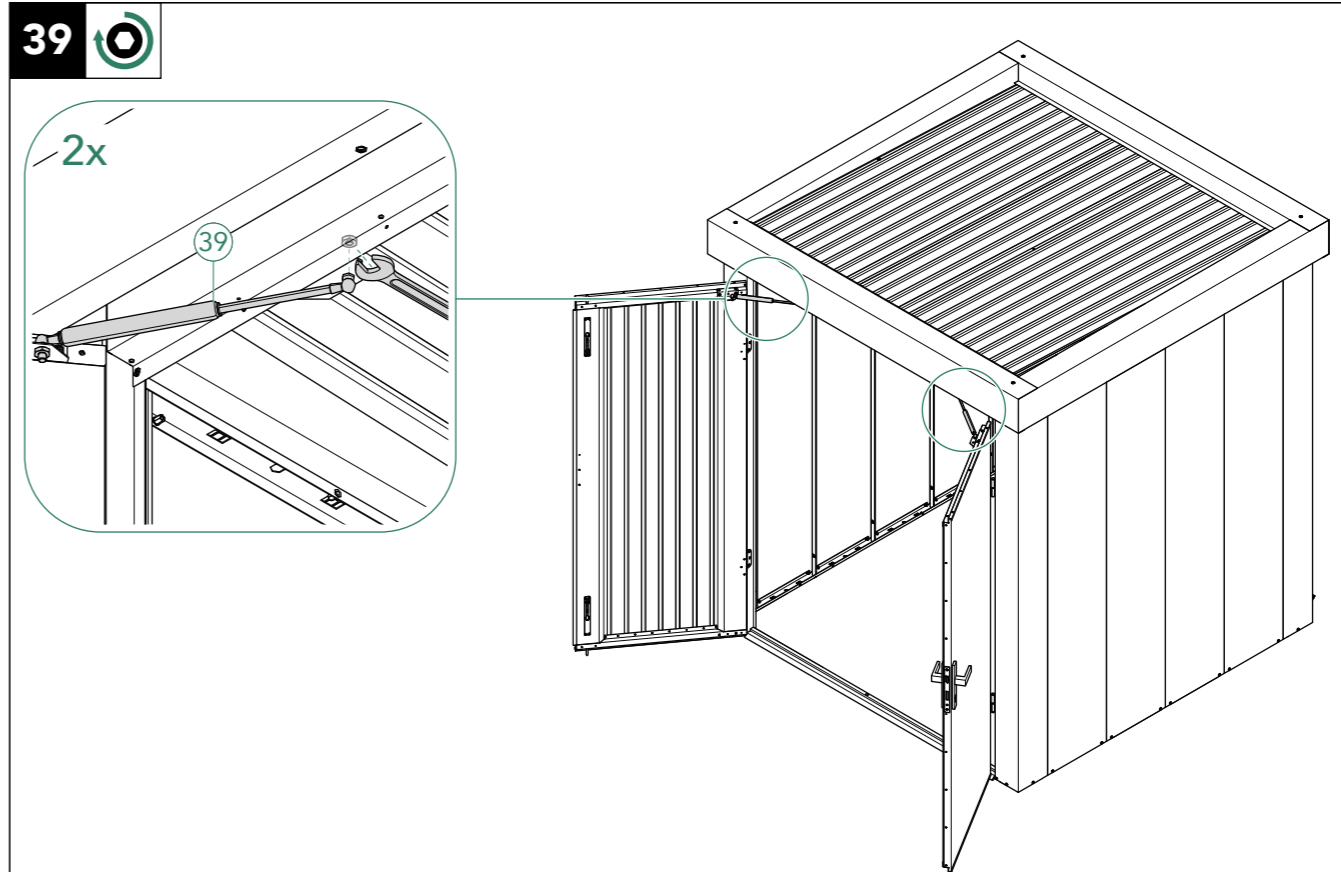

40

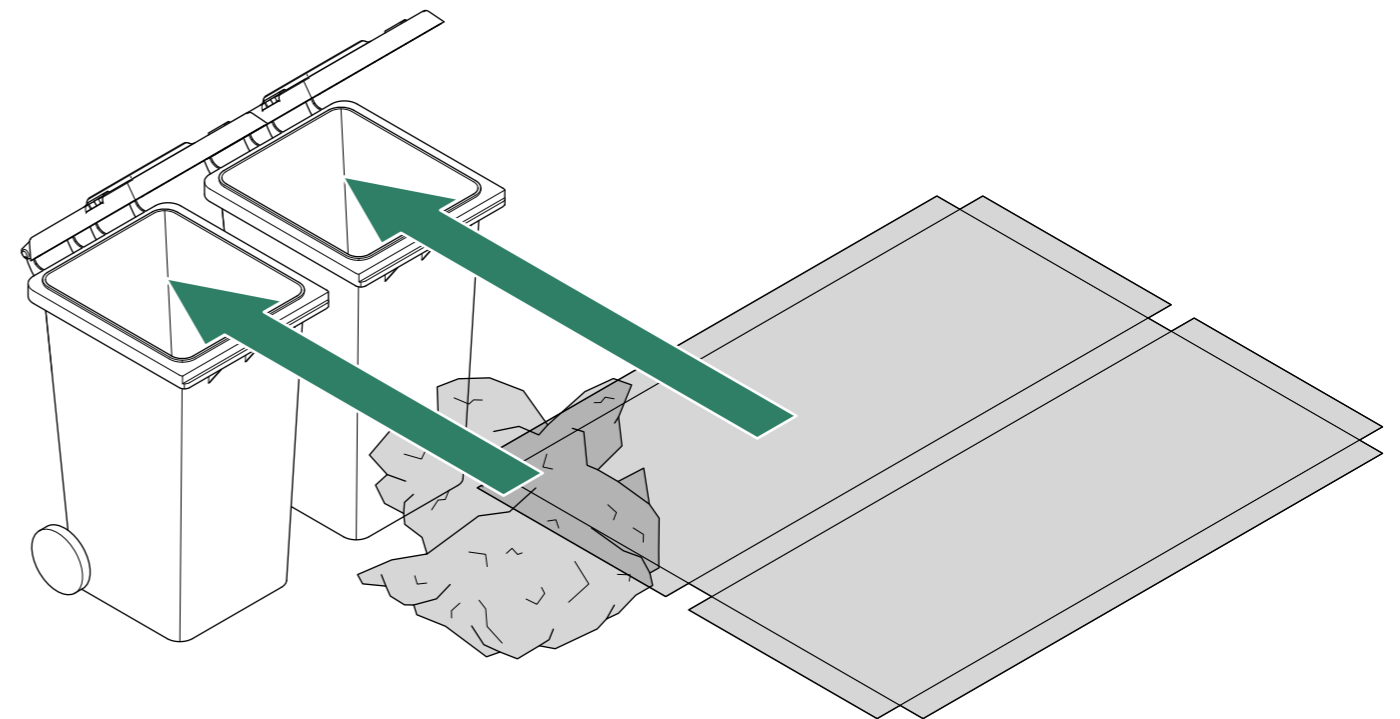

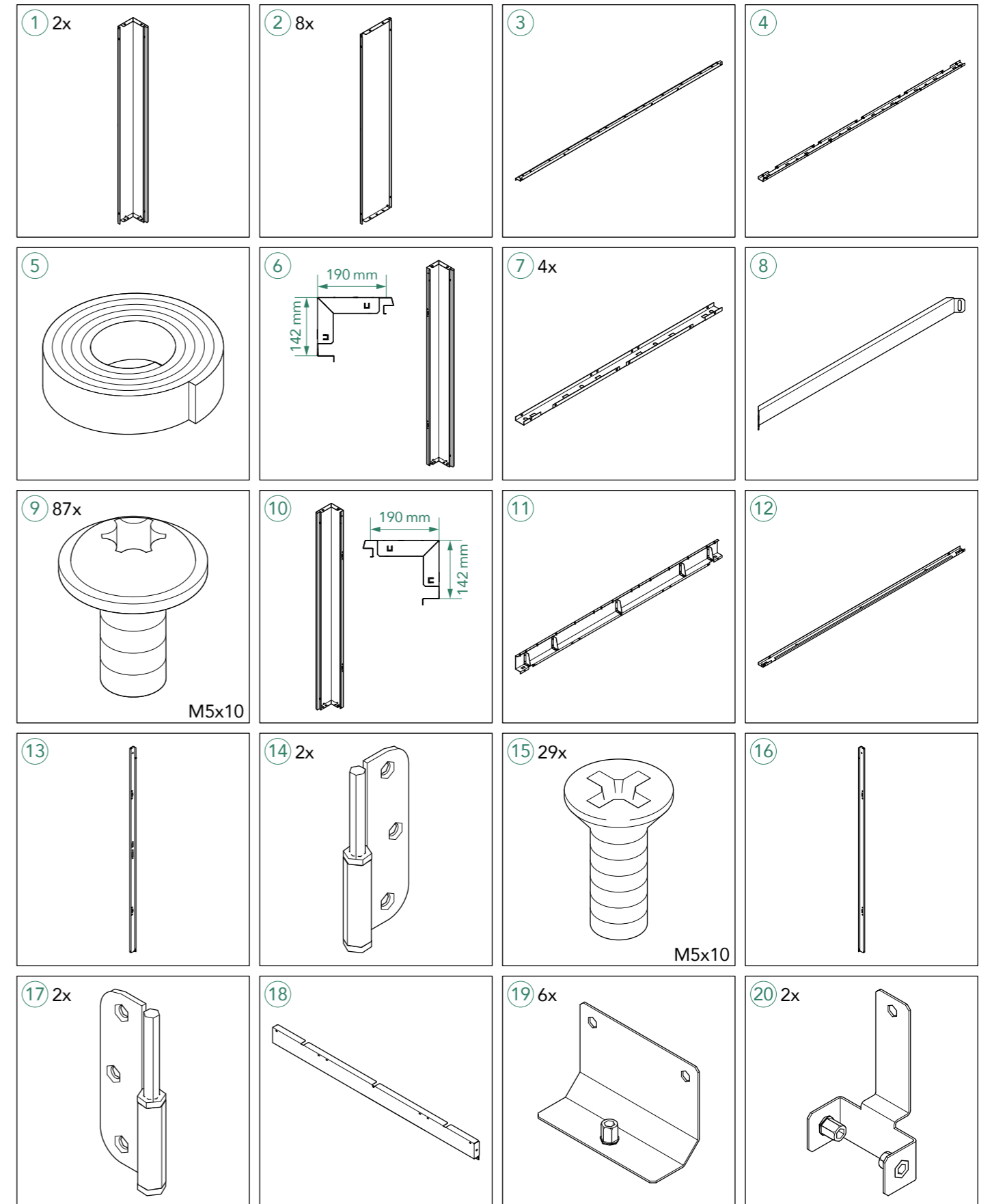
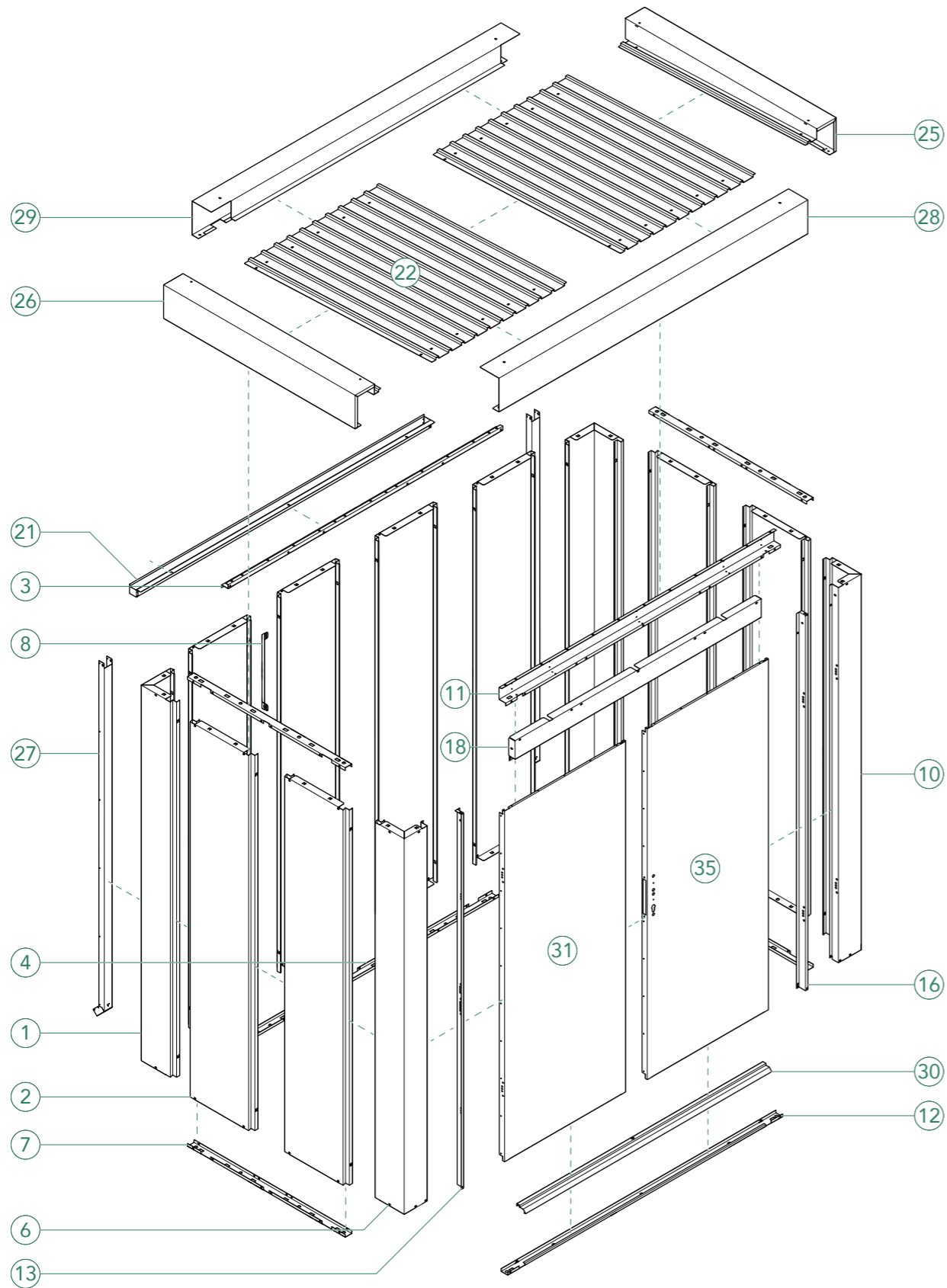

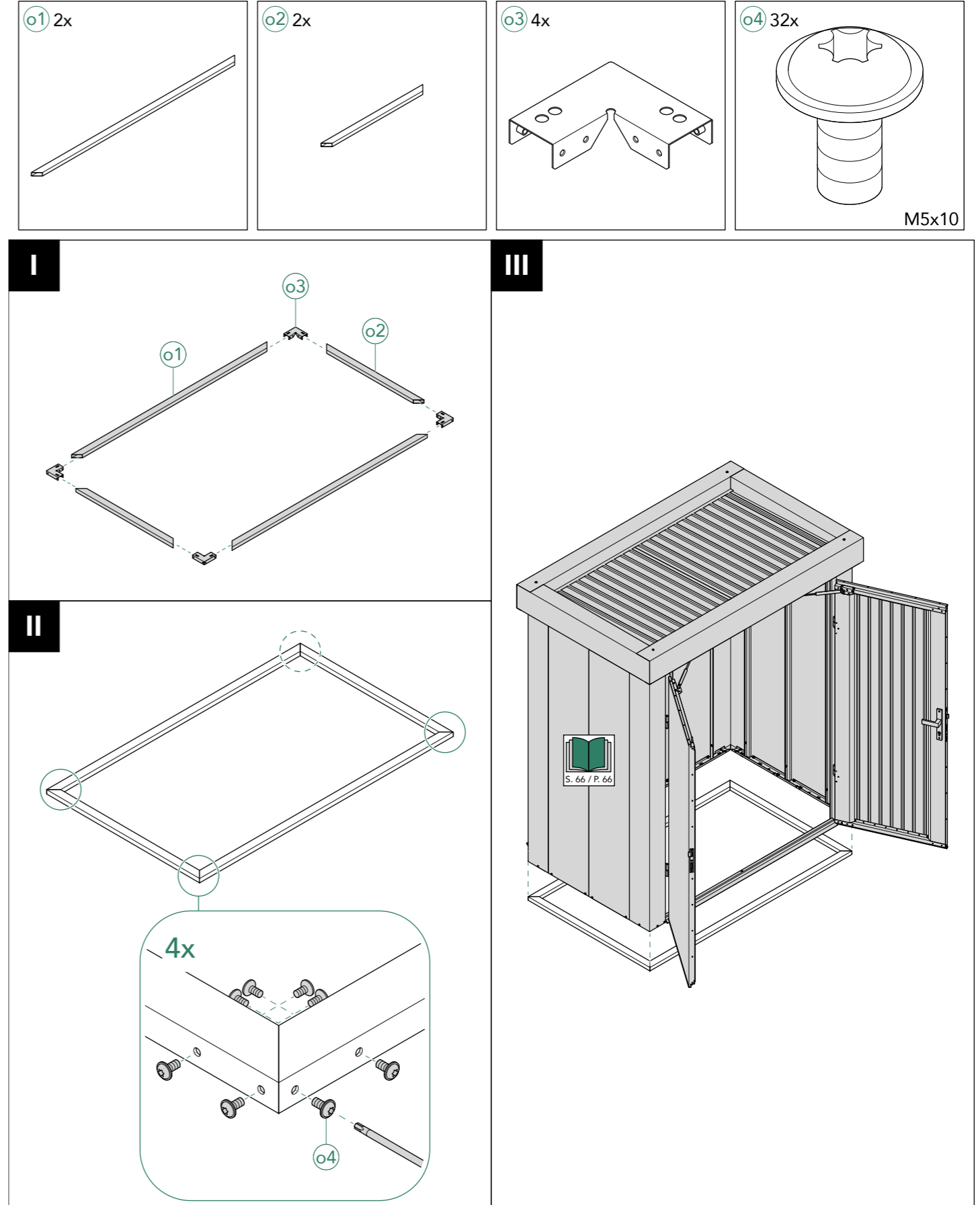
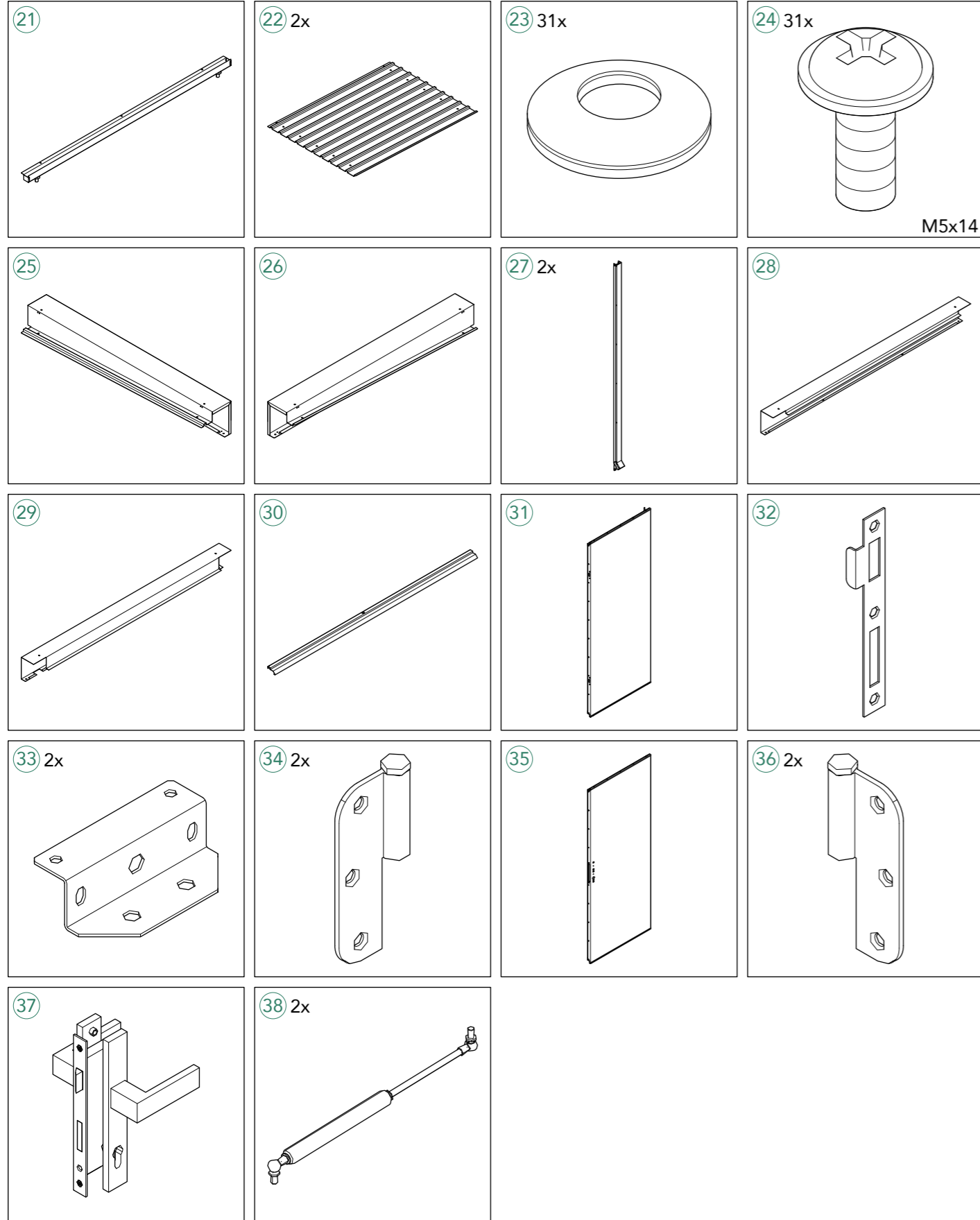

01

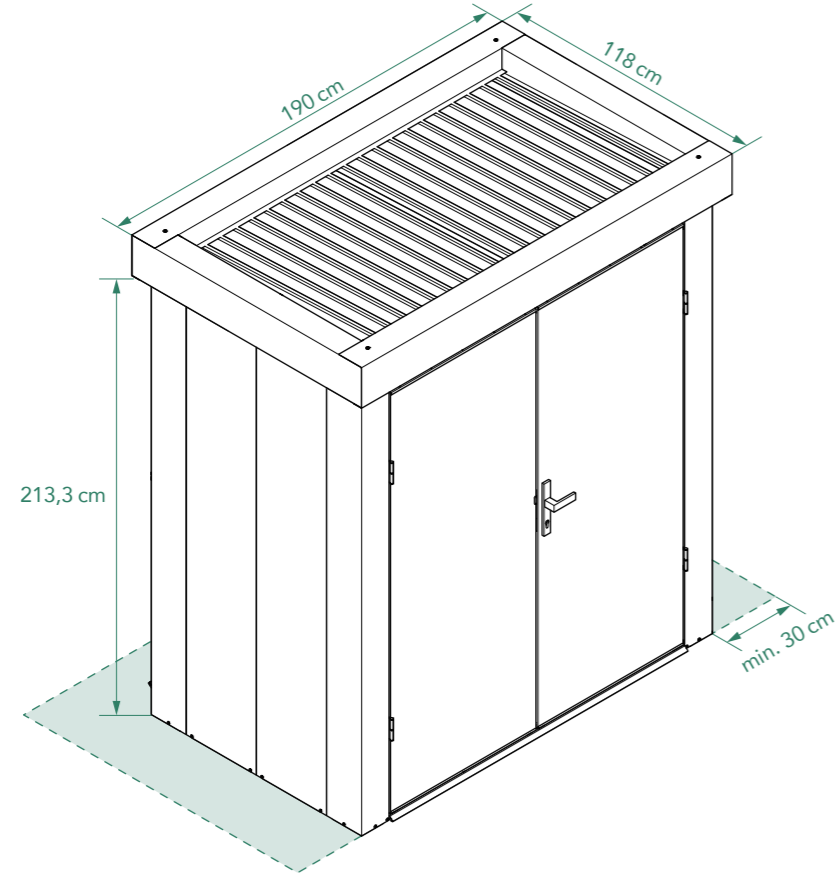

02

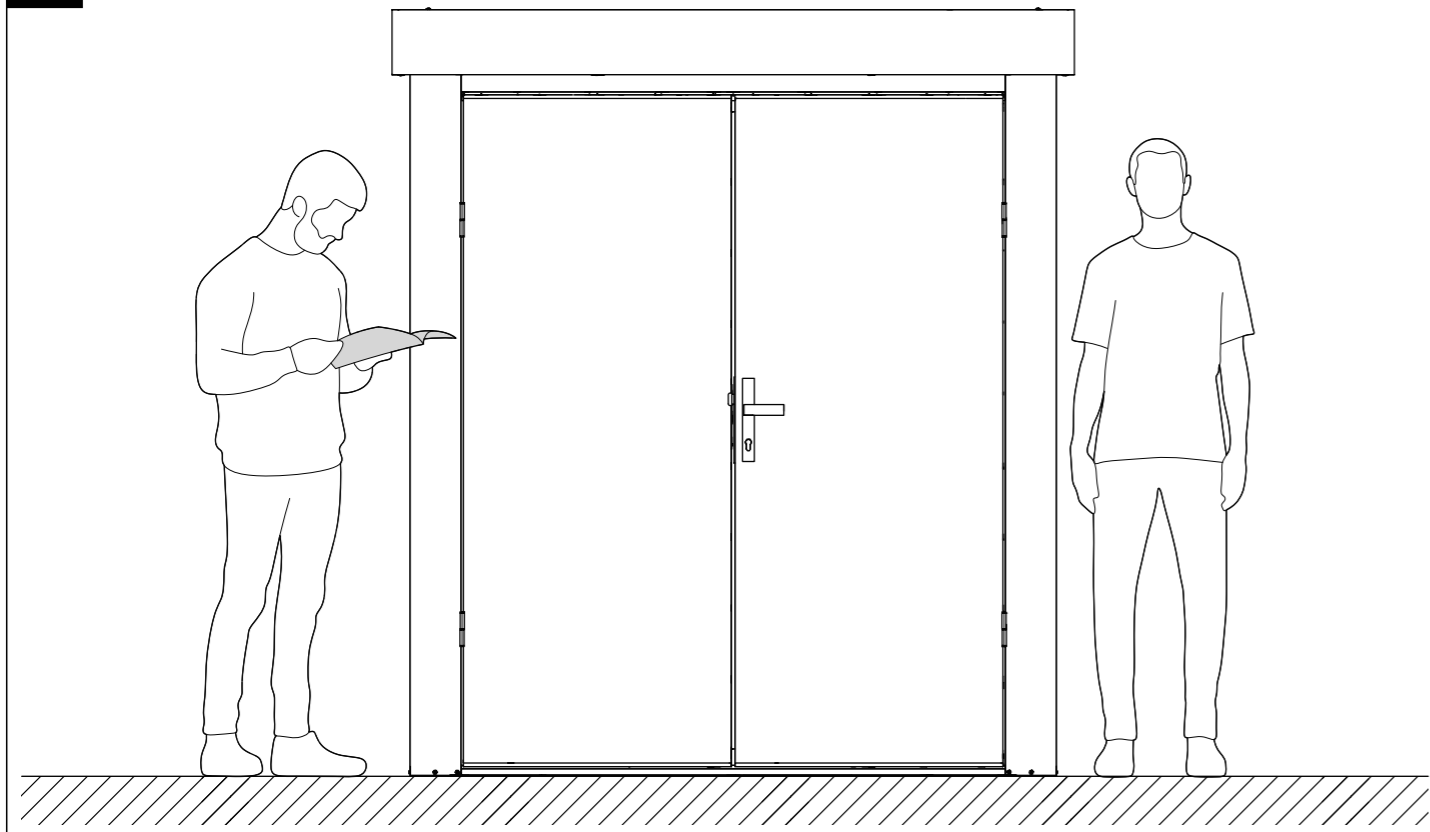

03

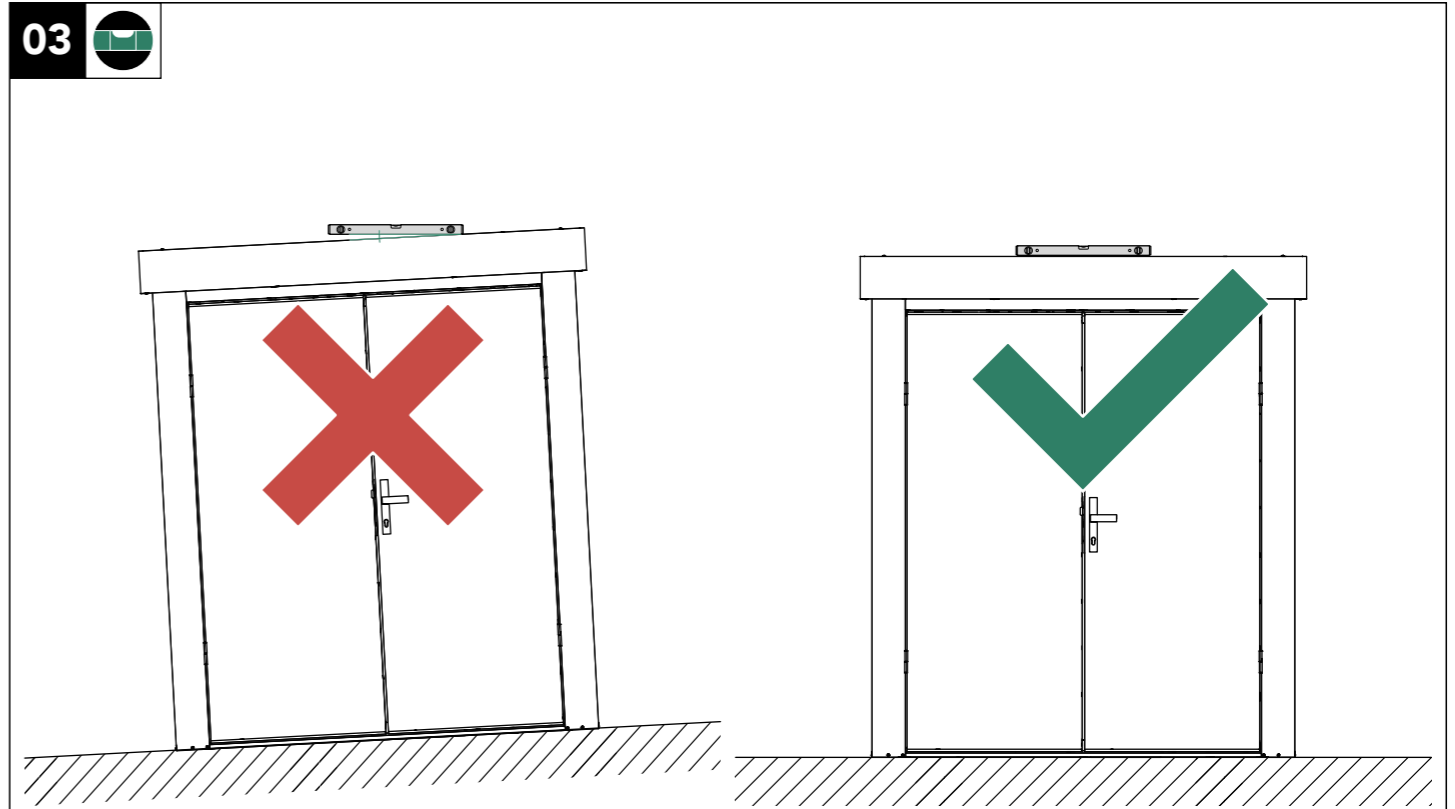

04

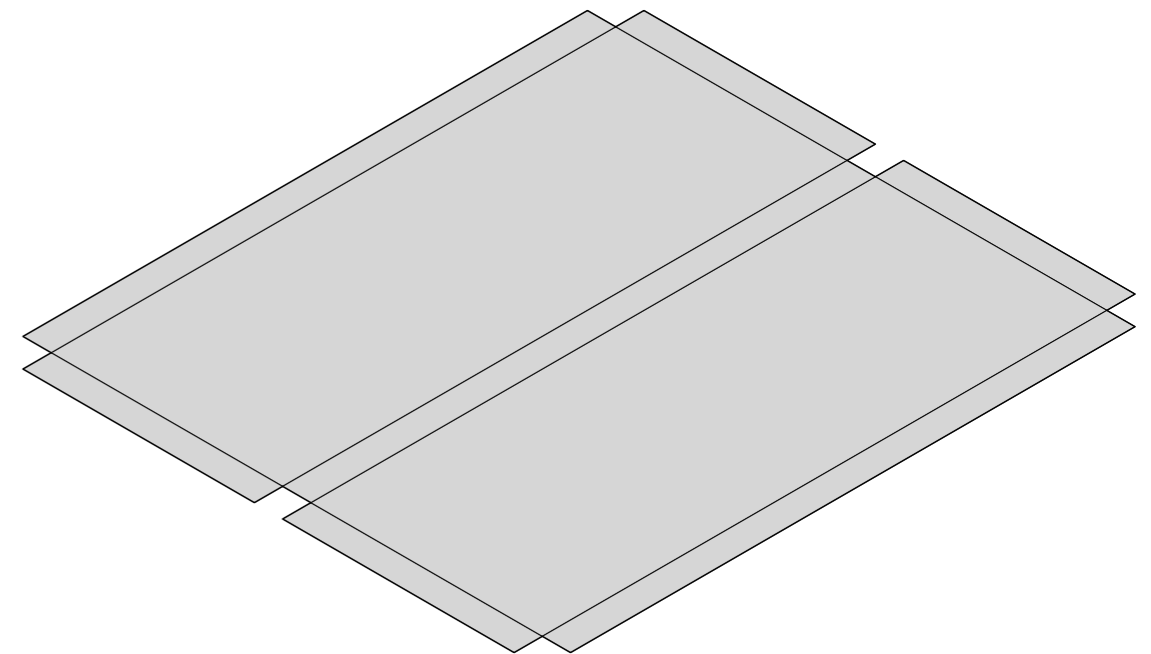

DE Kartonverpackung unterlegen
EN Underlay cardboard packaging

05

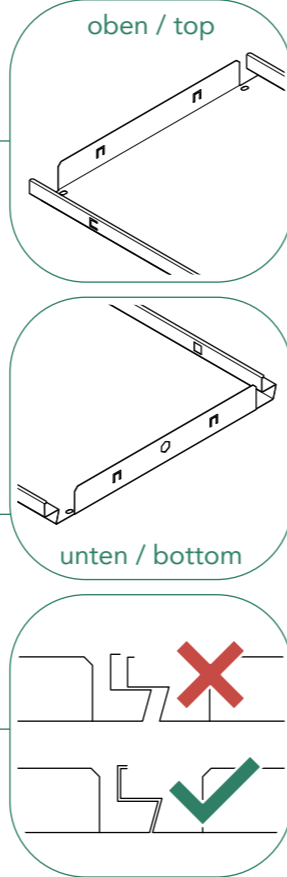
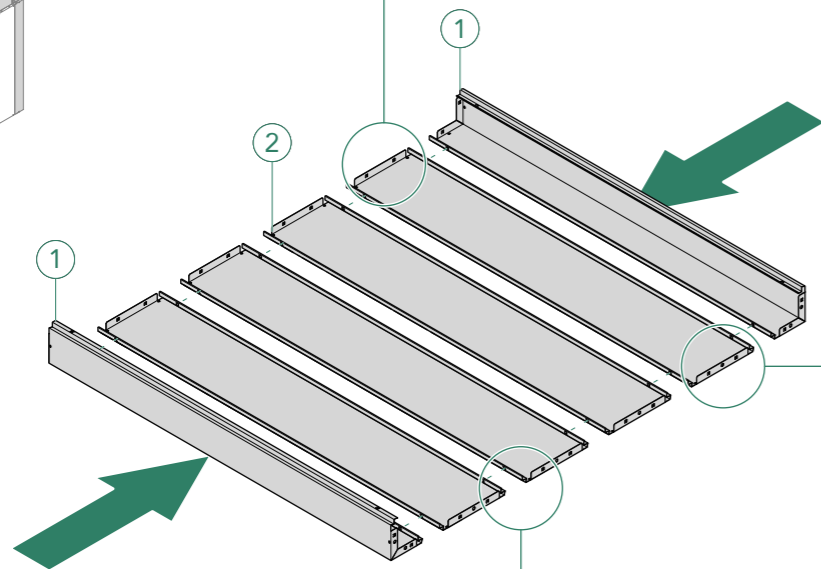
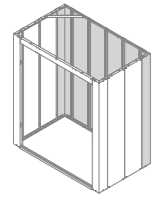

06

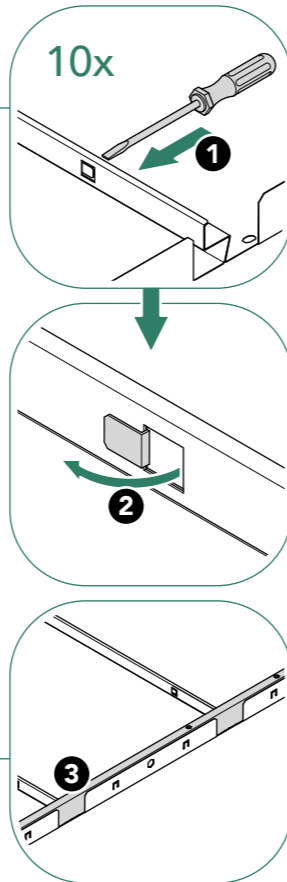
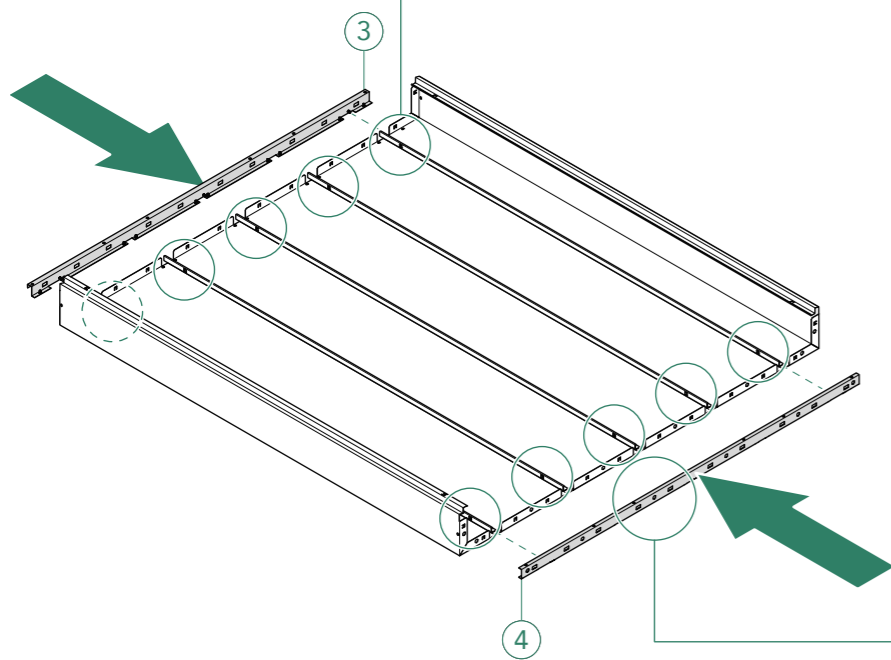

07

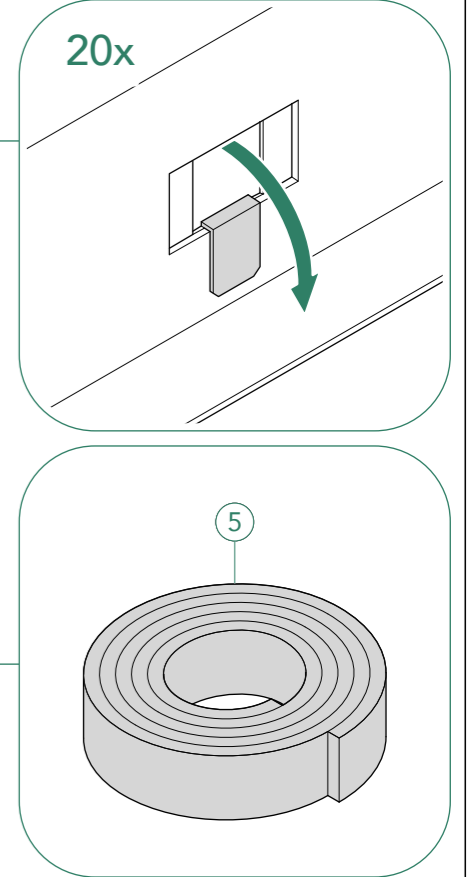
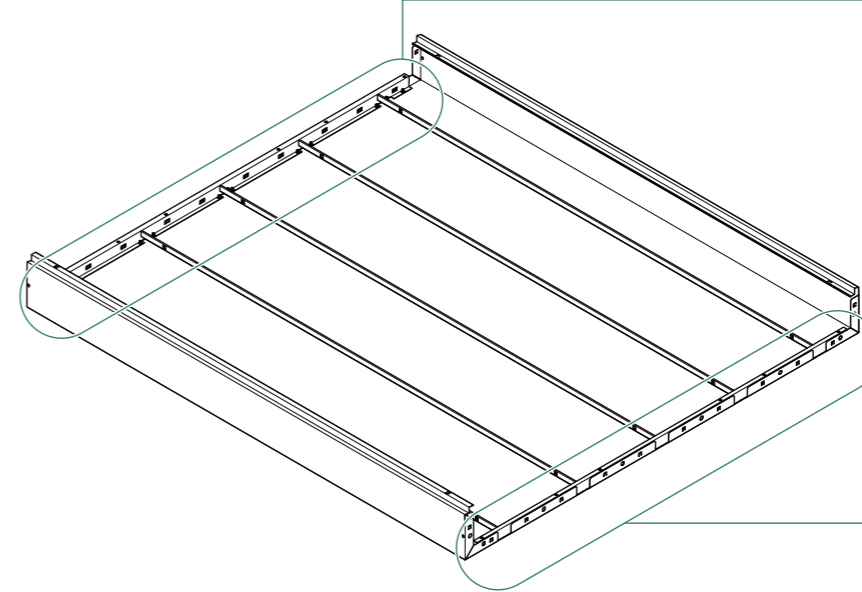

08

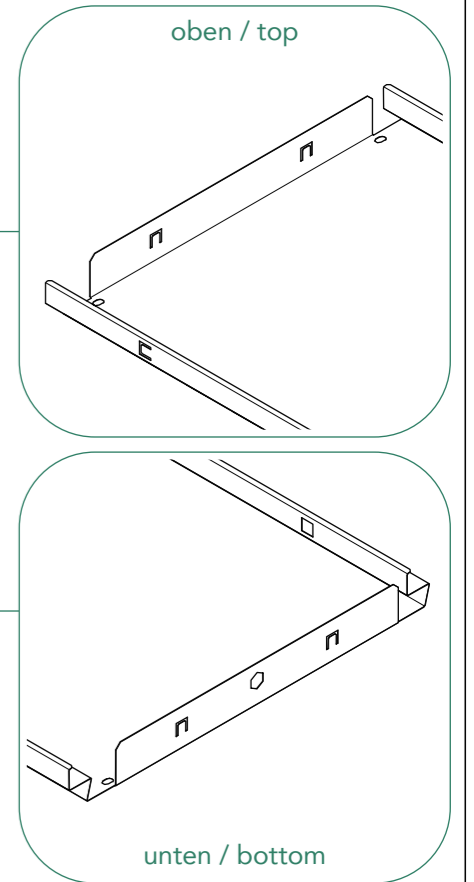
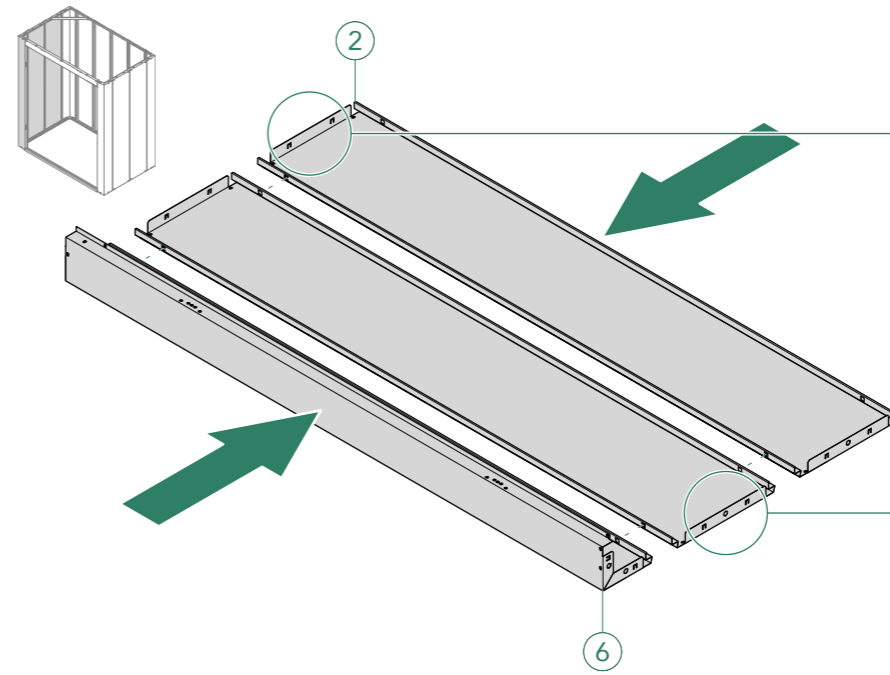

09

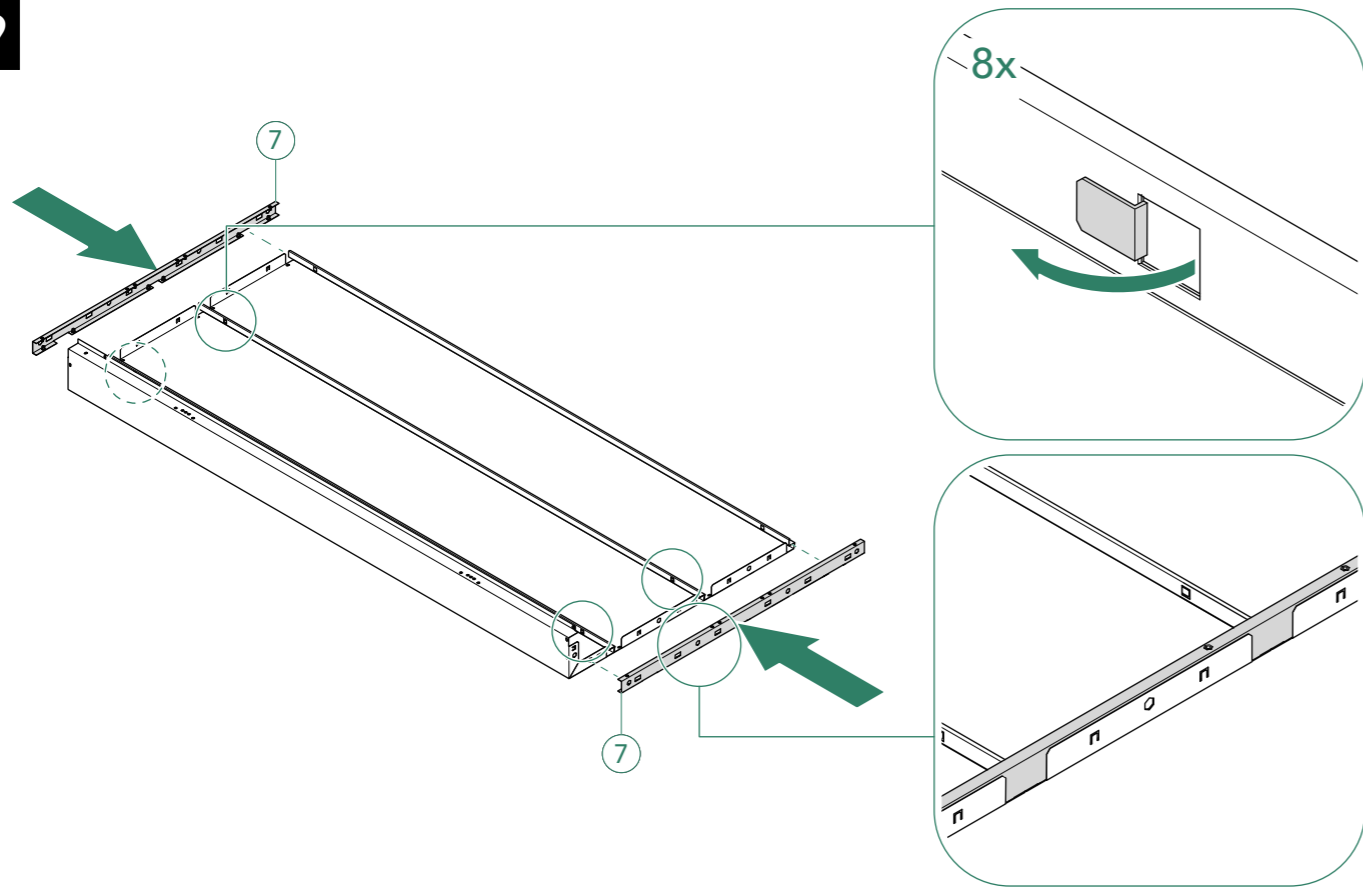

10

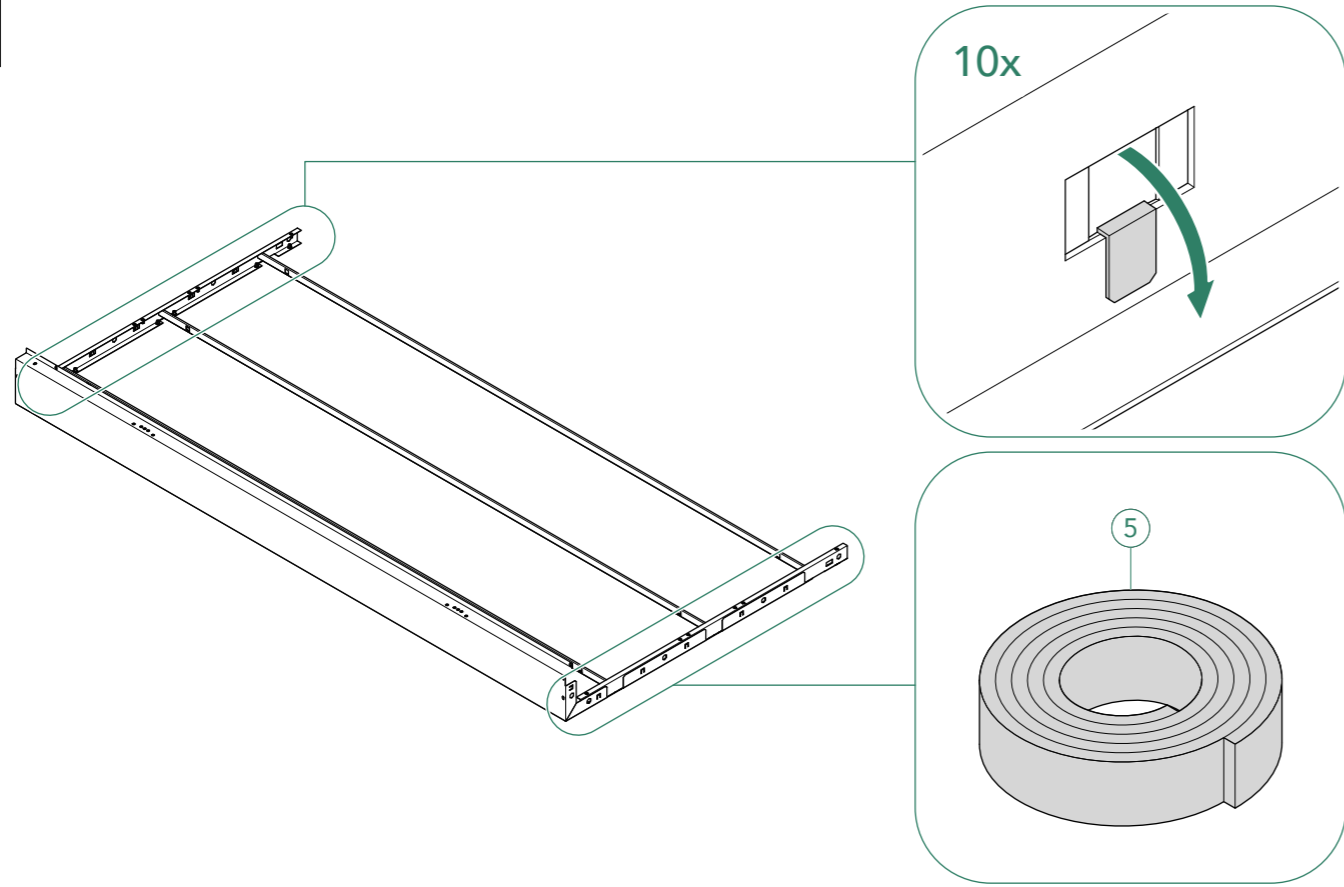

11

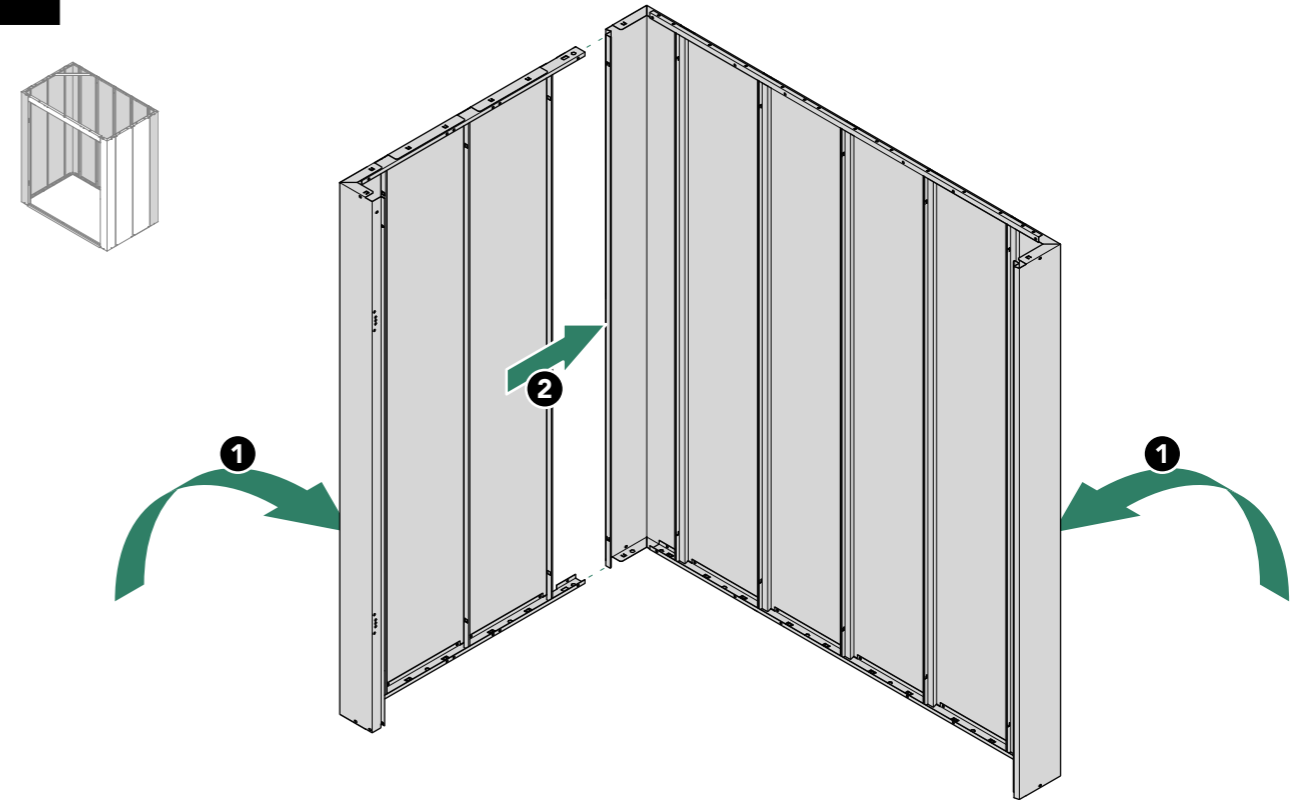

12

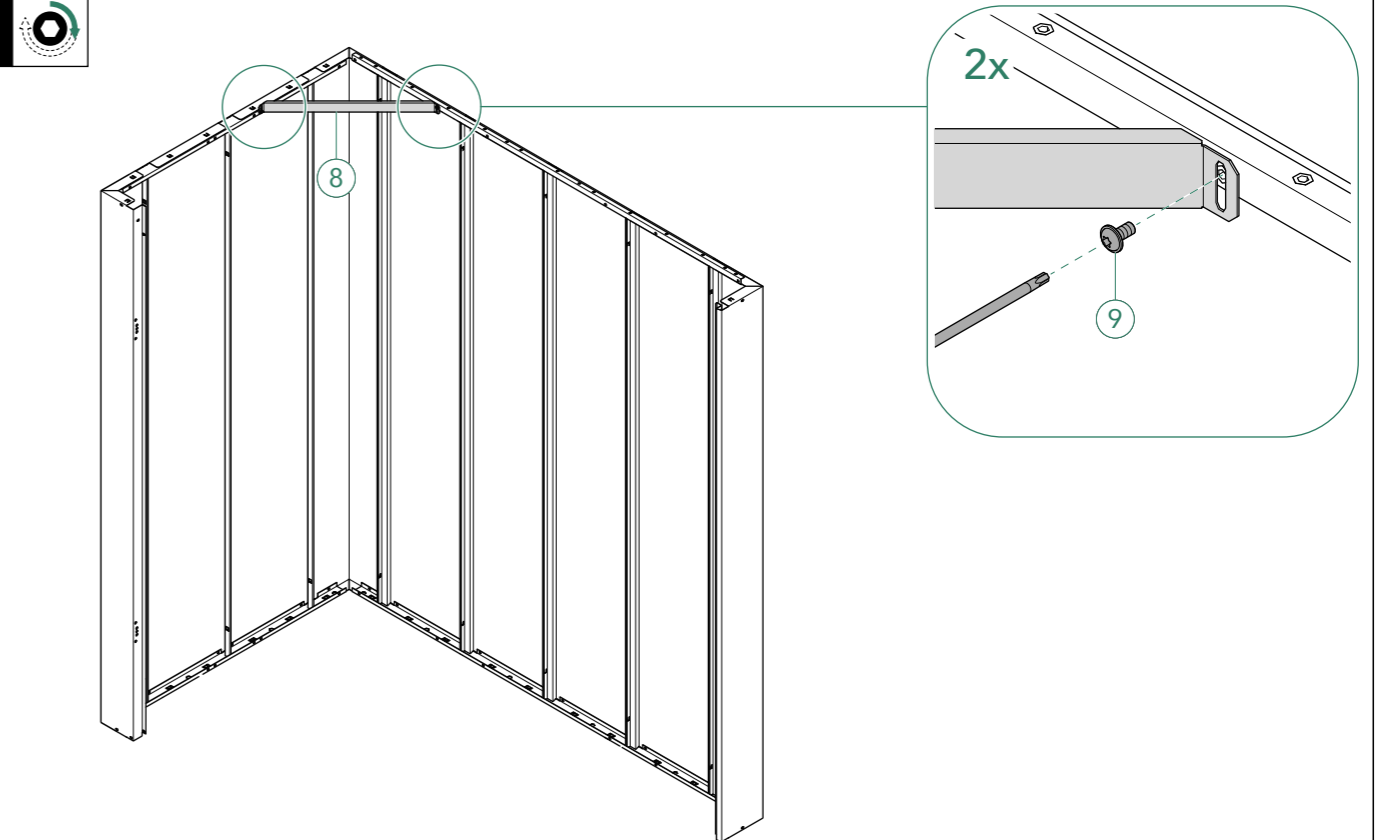

13

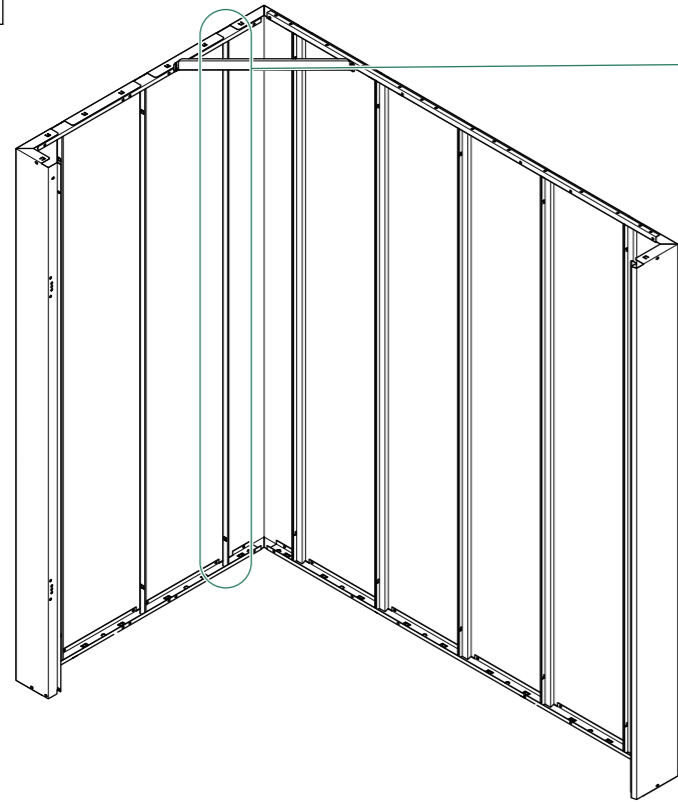

4x

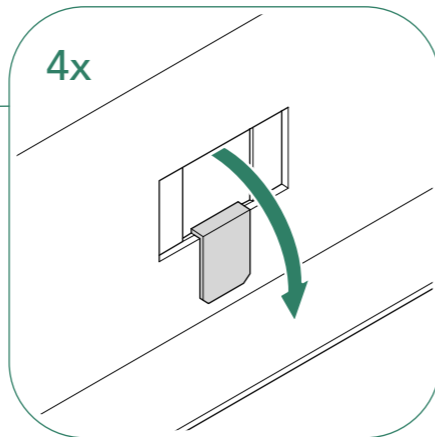

2x

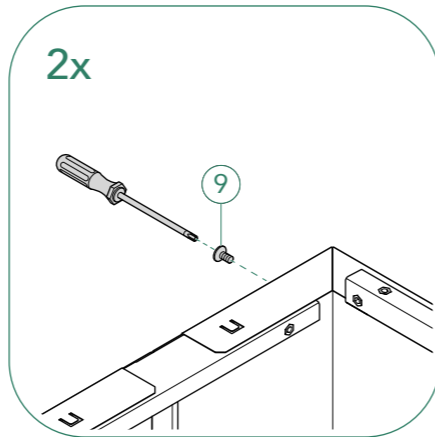

14

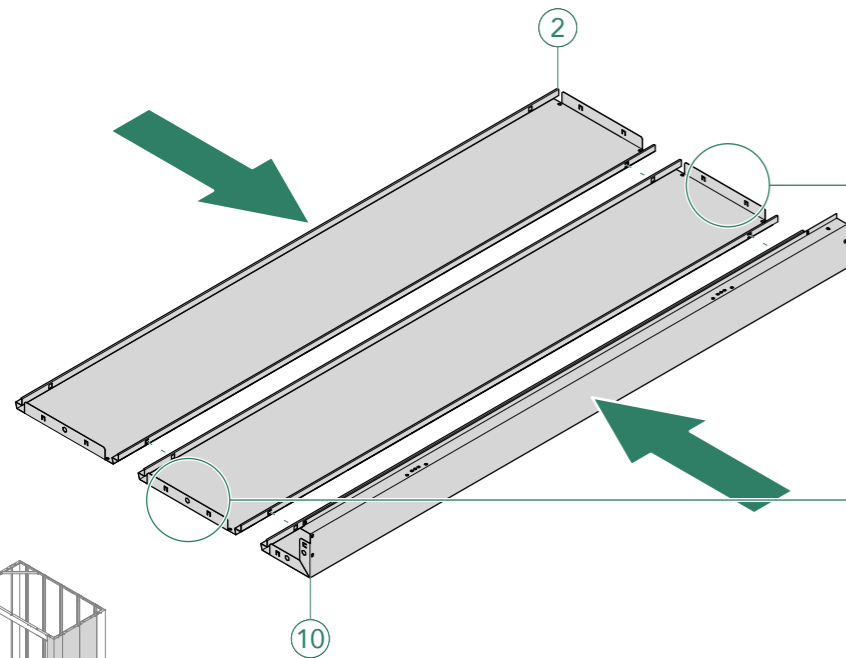

oben / top

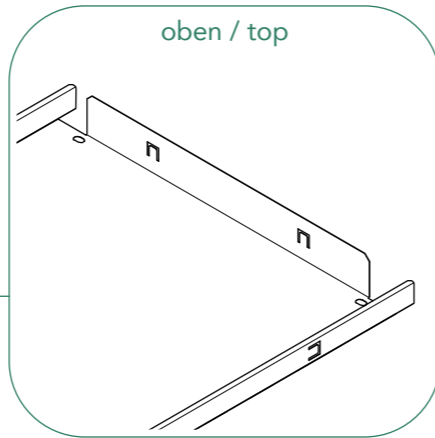

unten / bottom

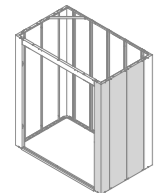
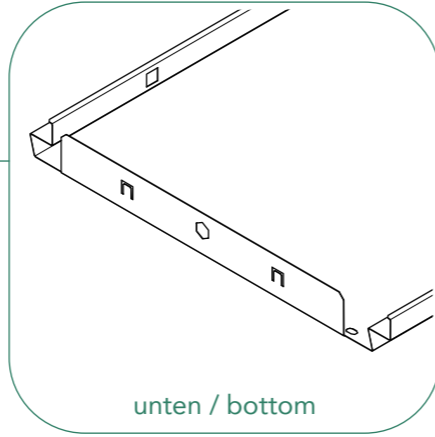

15

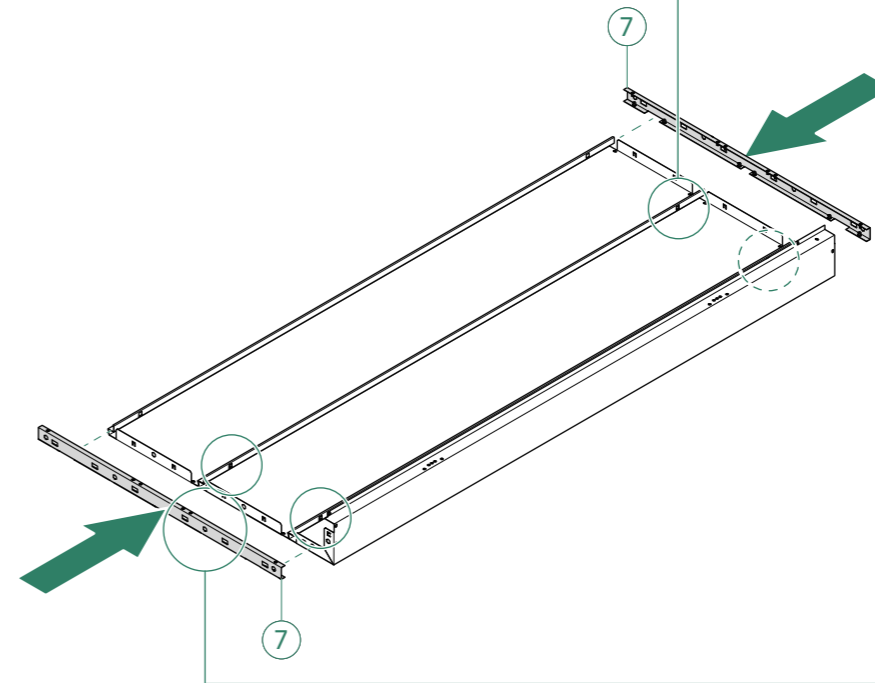

8x

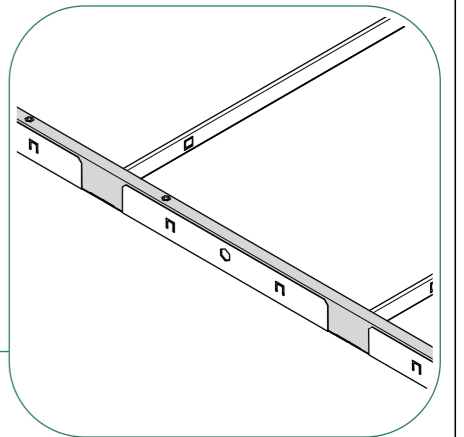
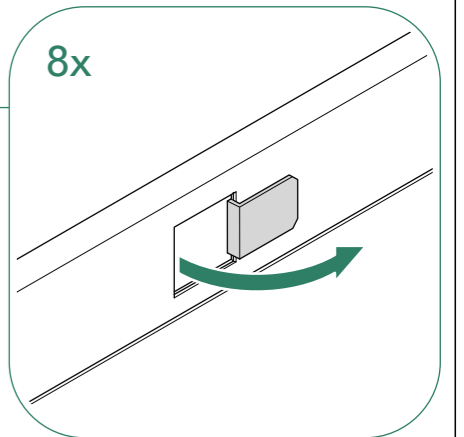

16

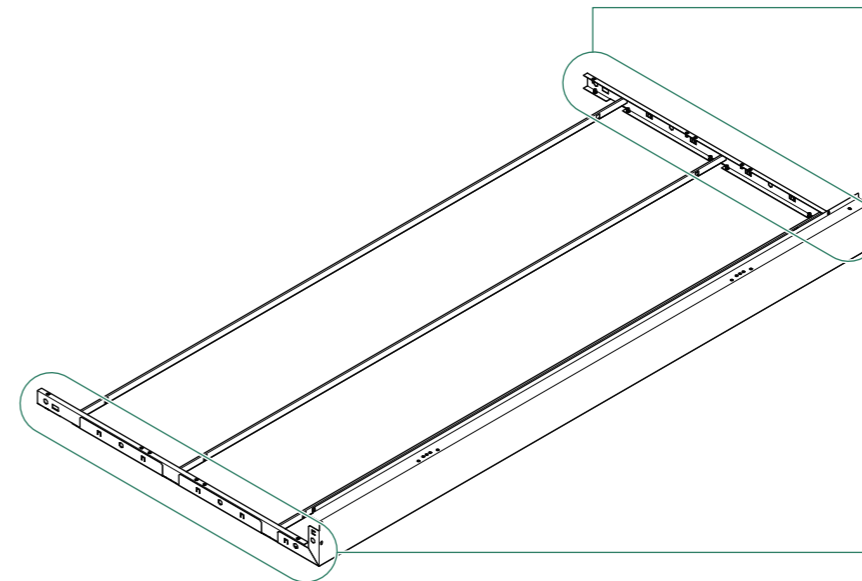

10x

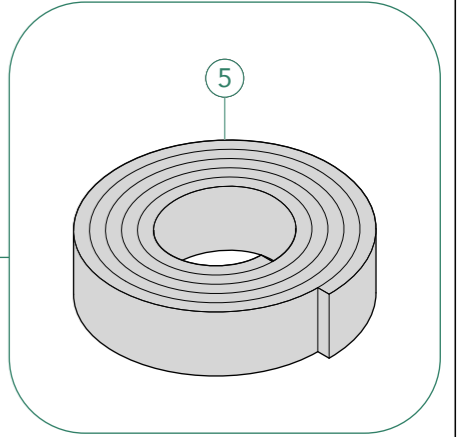
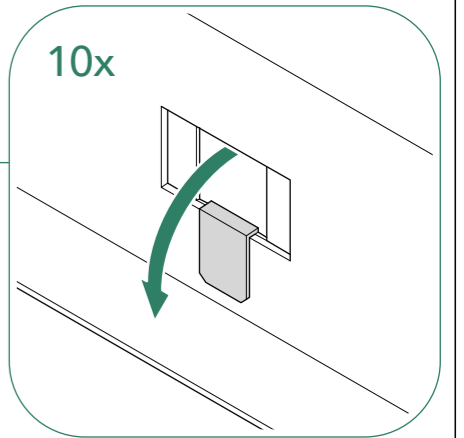

17

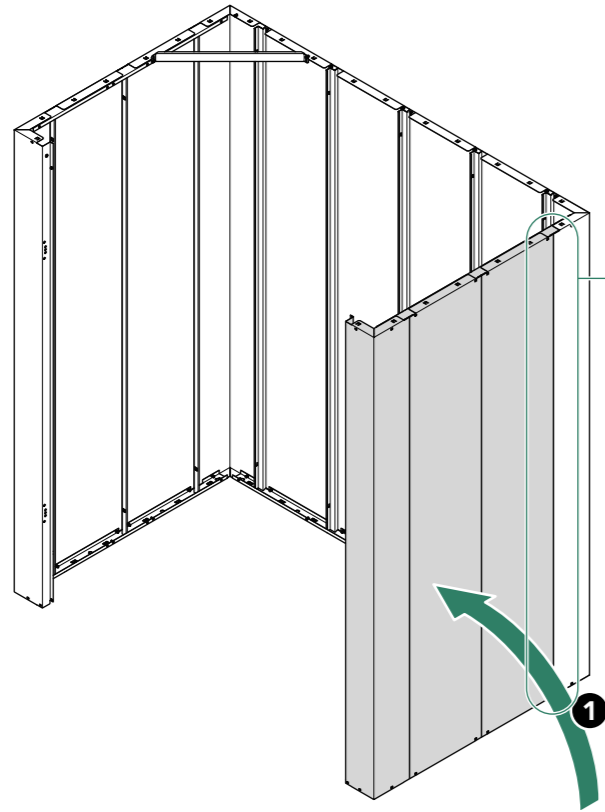

4x

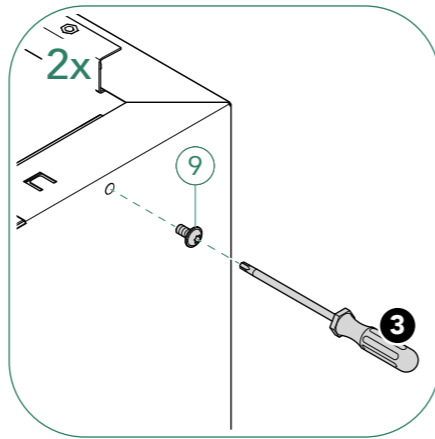
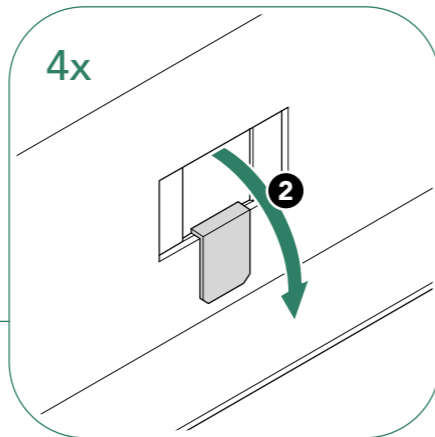

18

4x

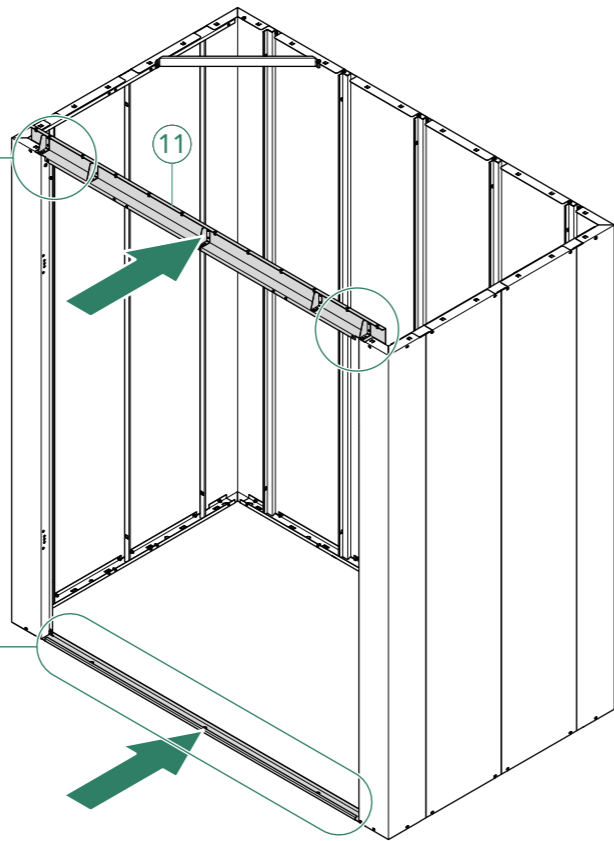
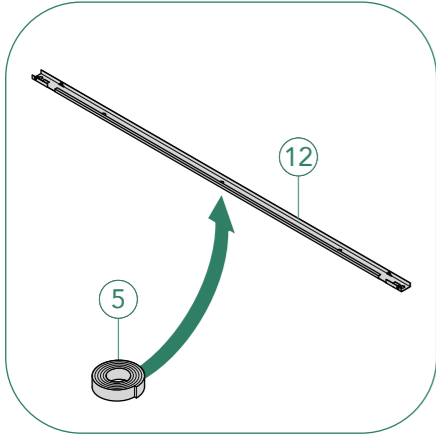
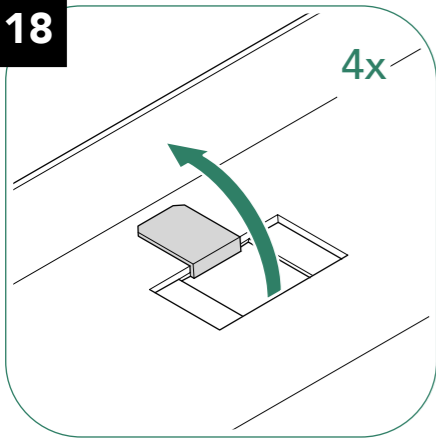

19



2x

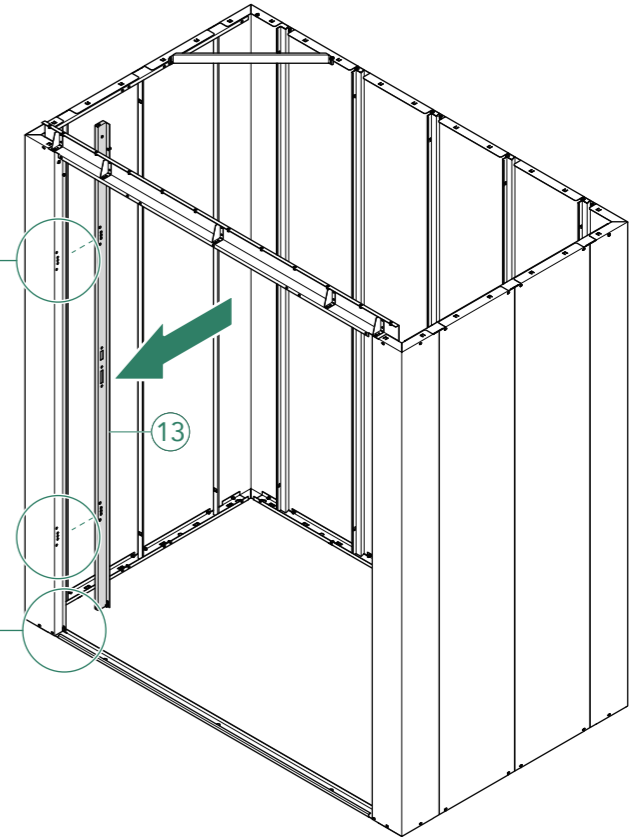
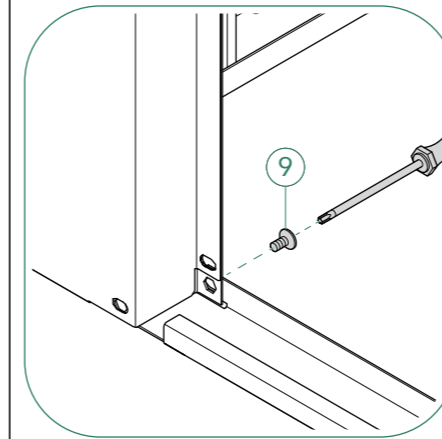
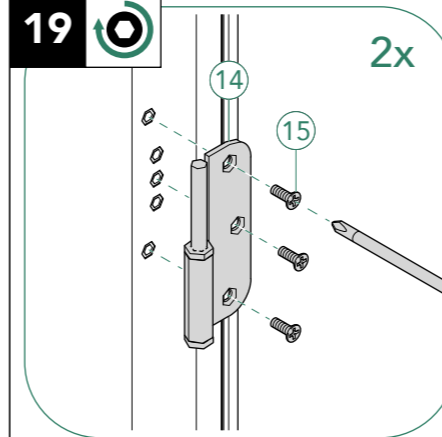

20



2x

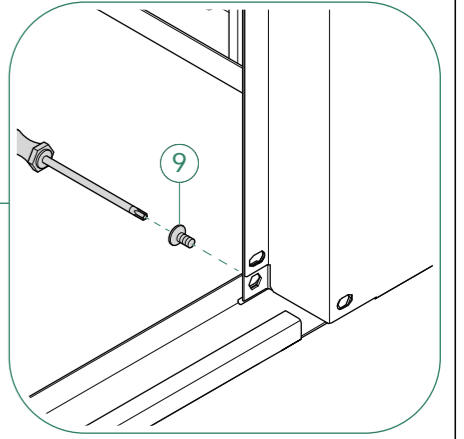
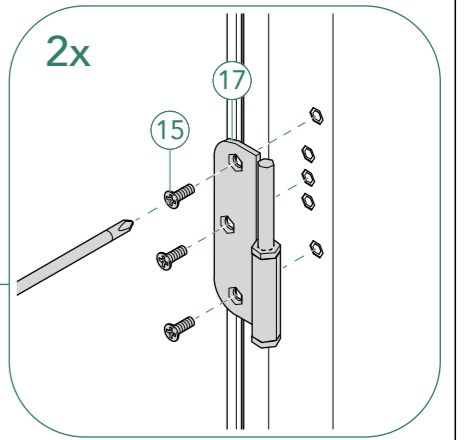
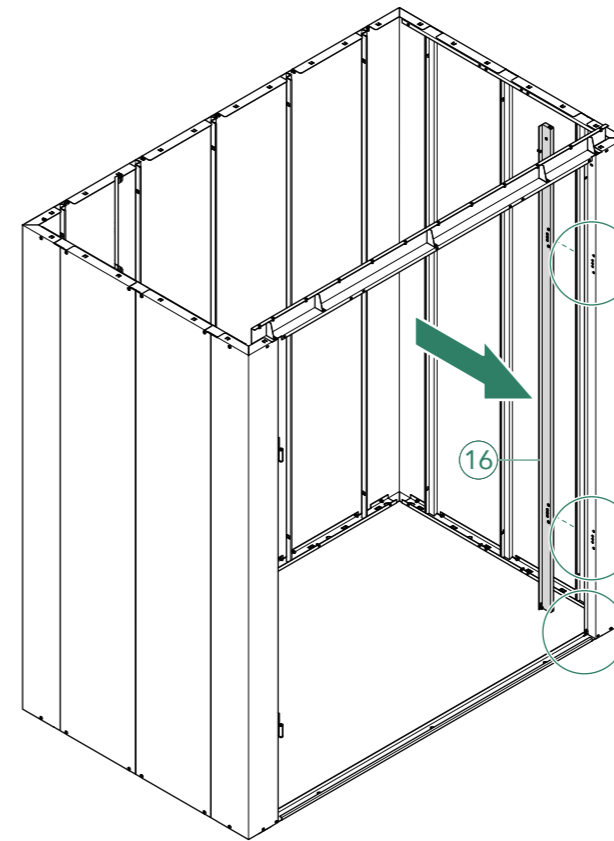

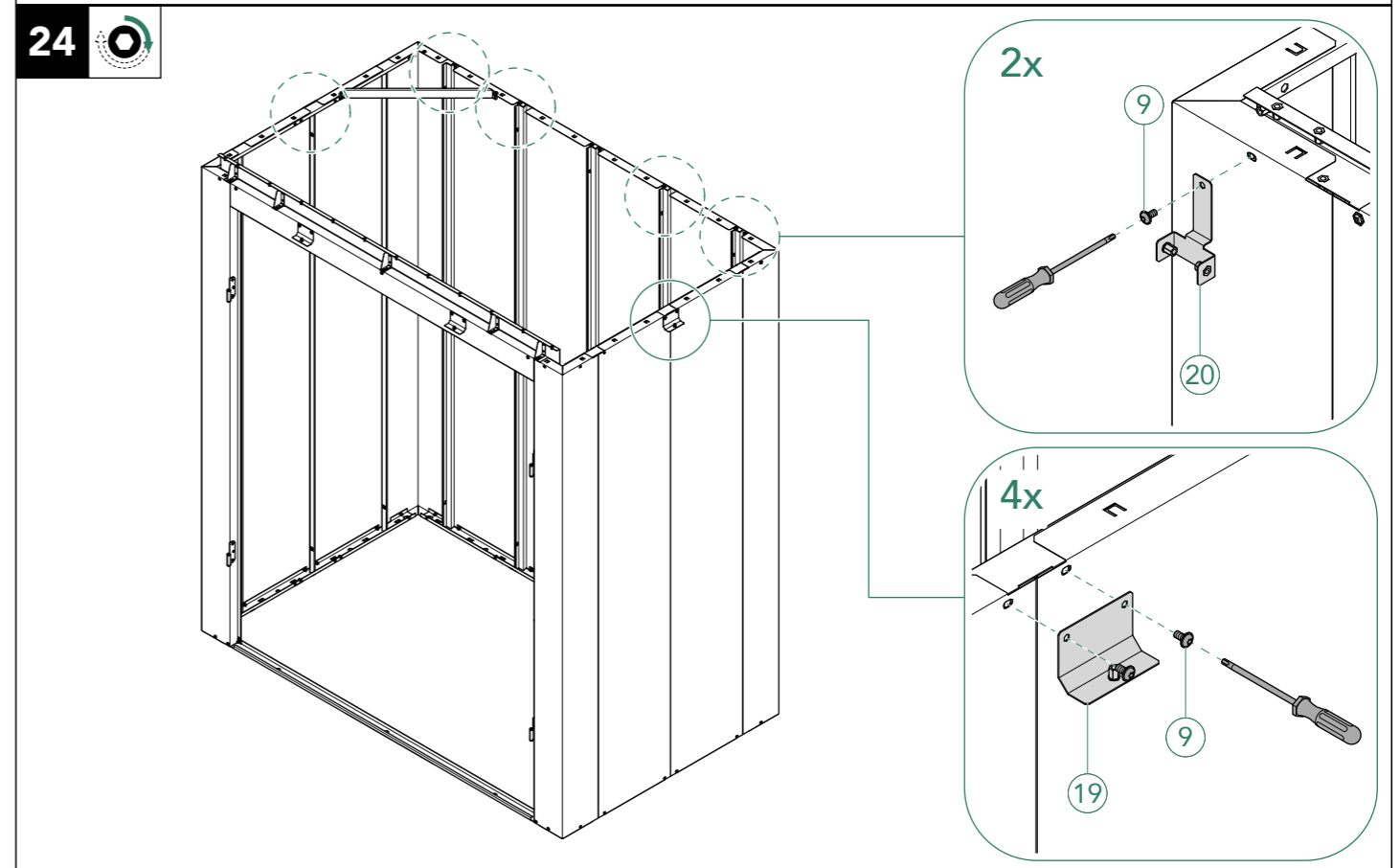
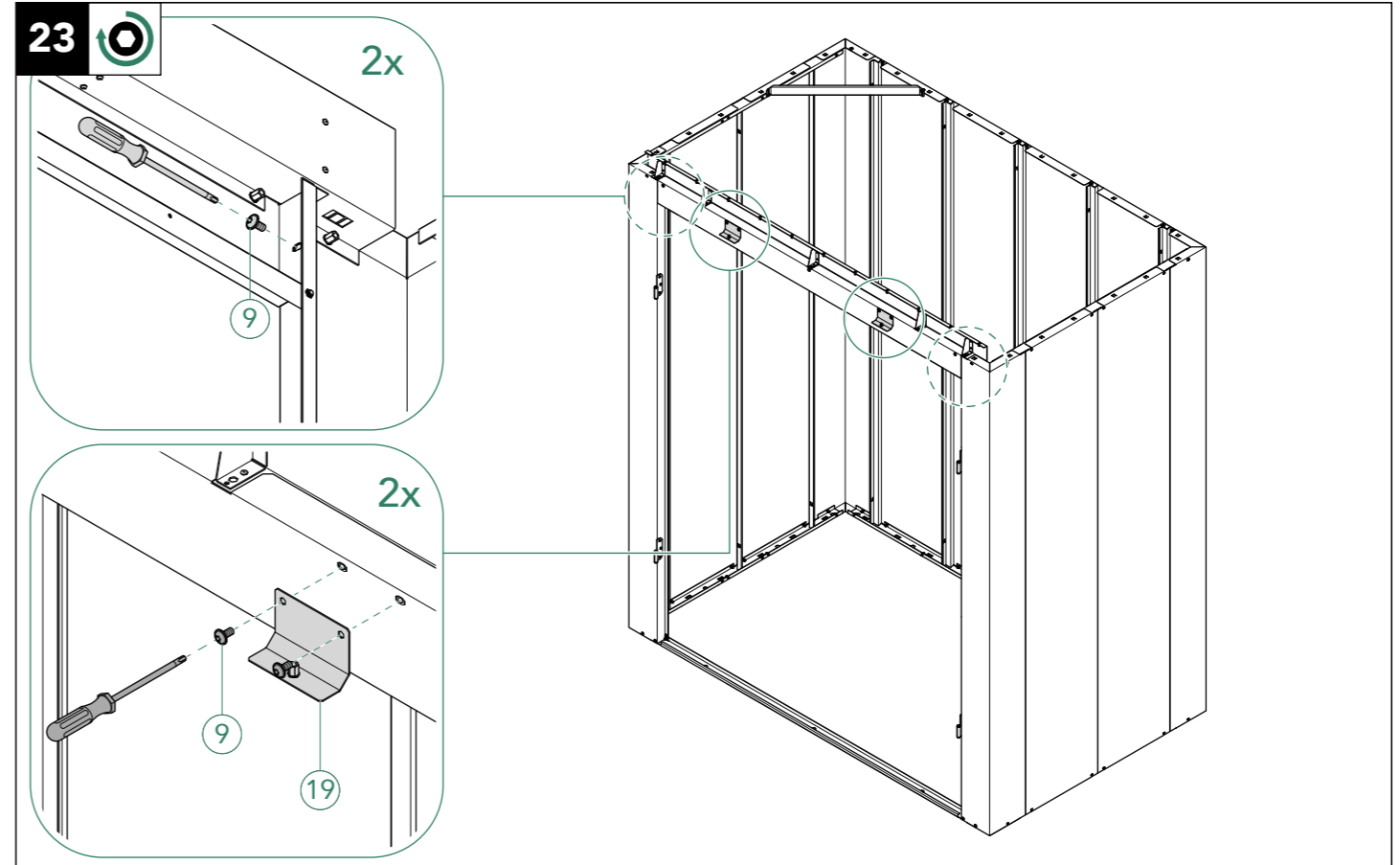
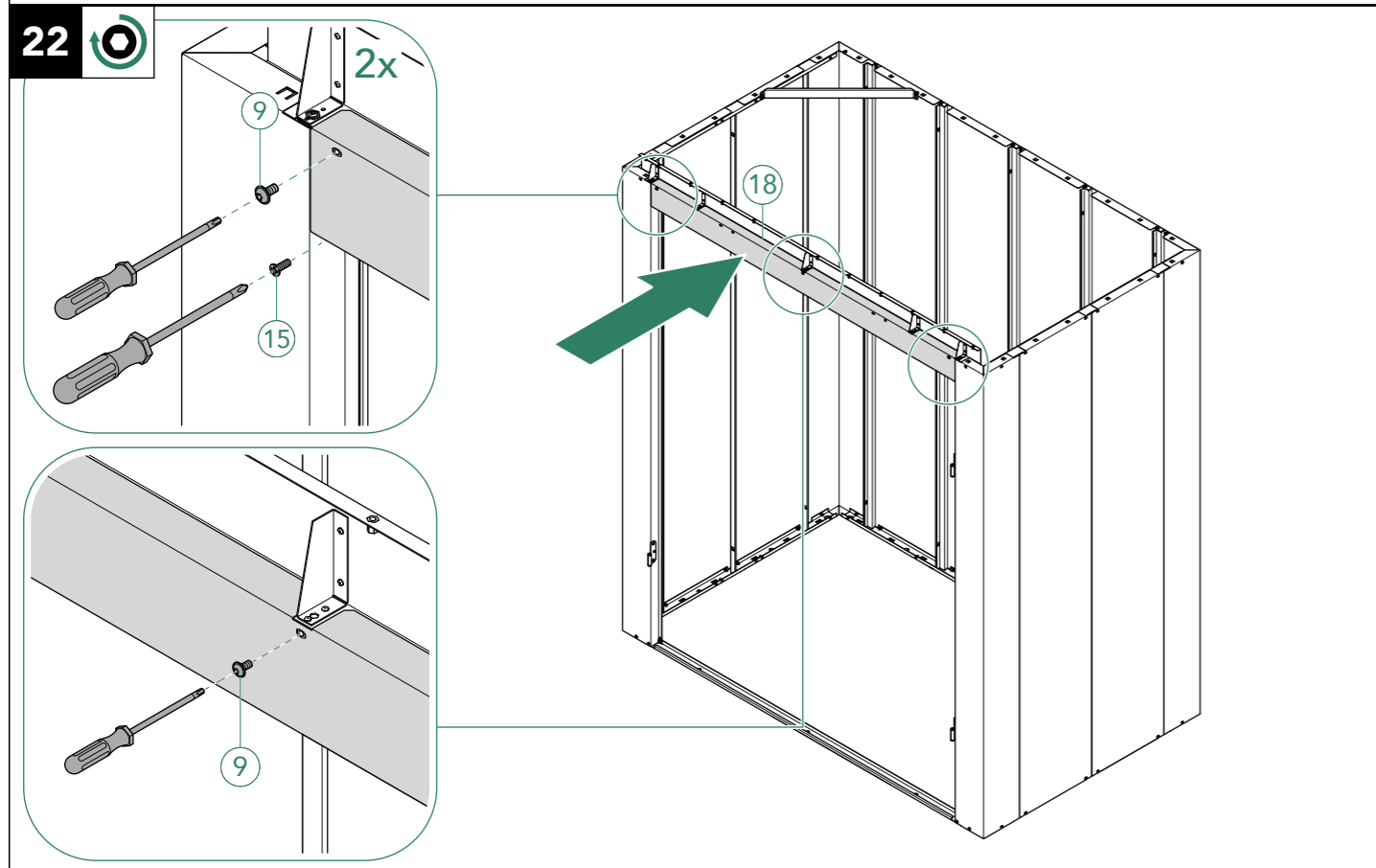
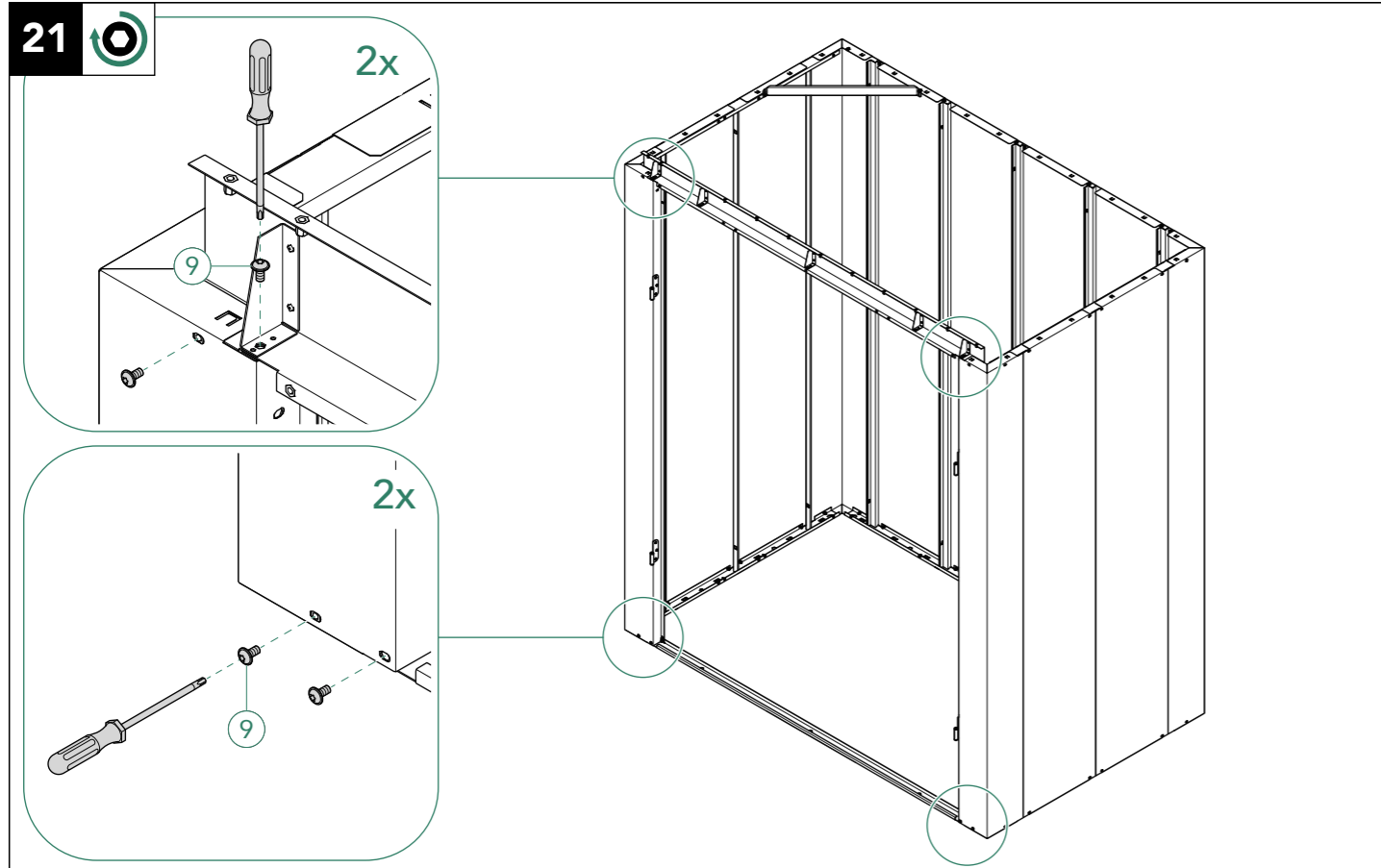

25

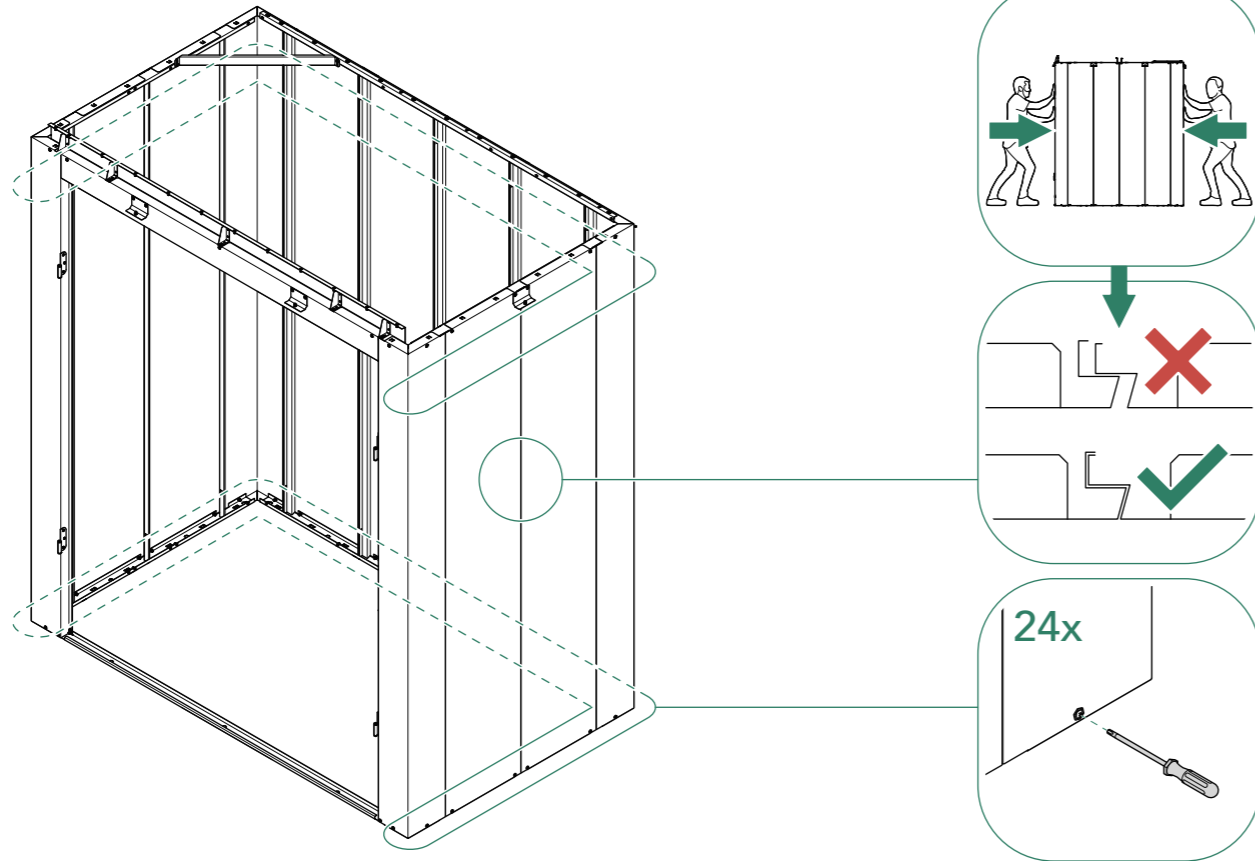

26

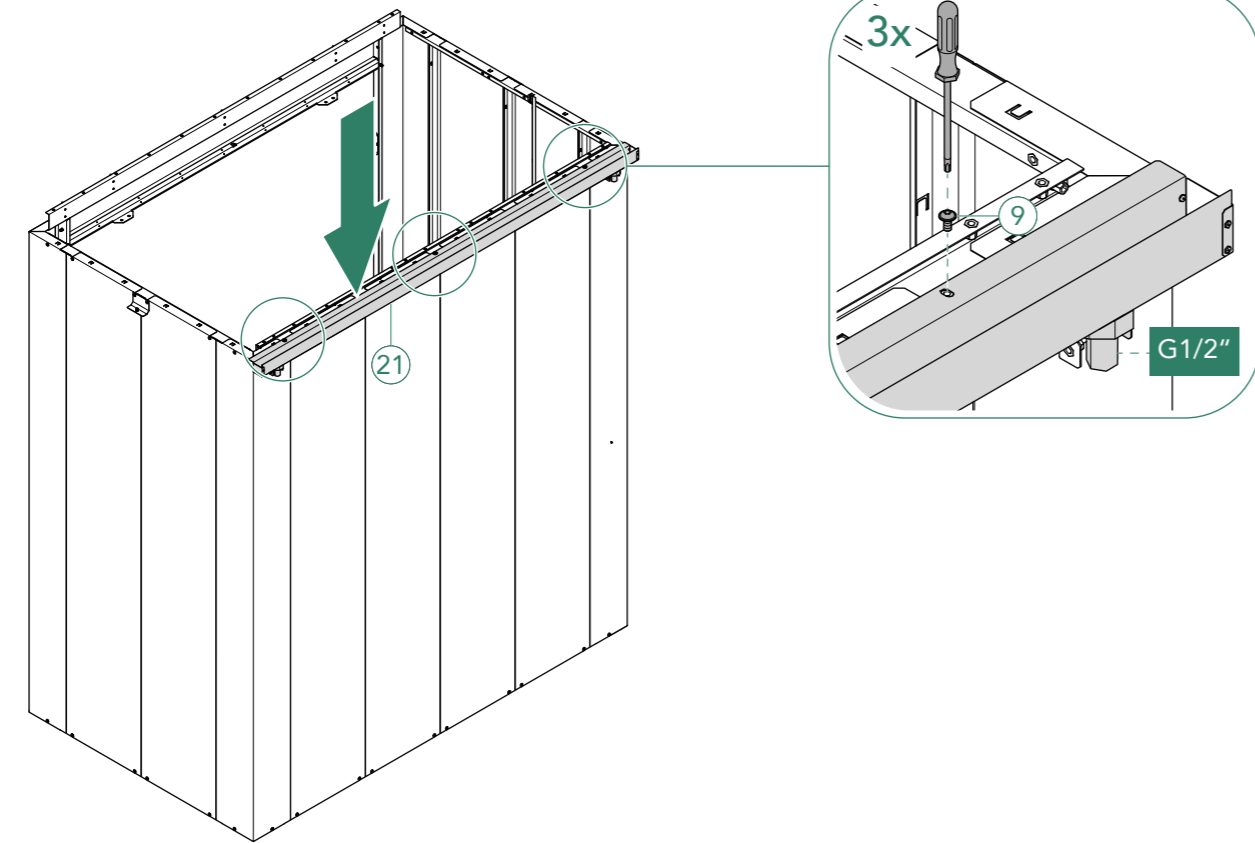

27

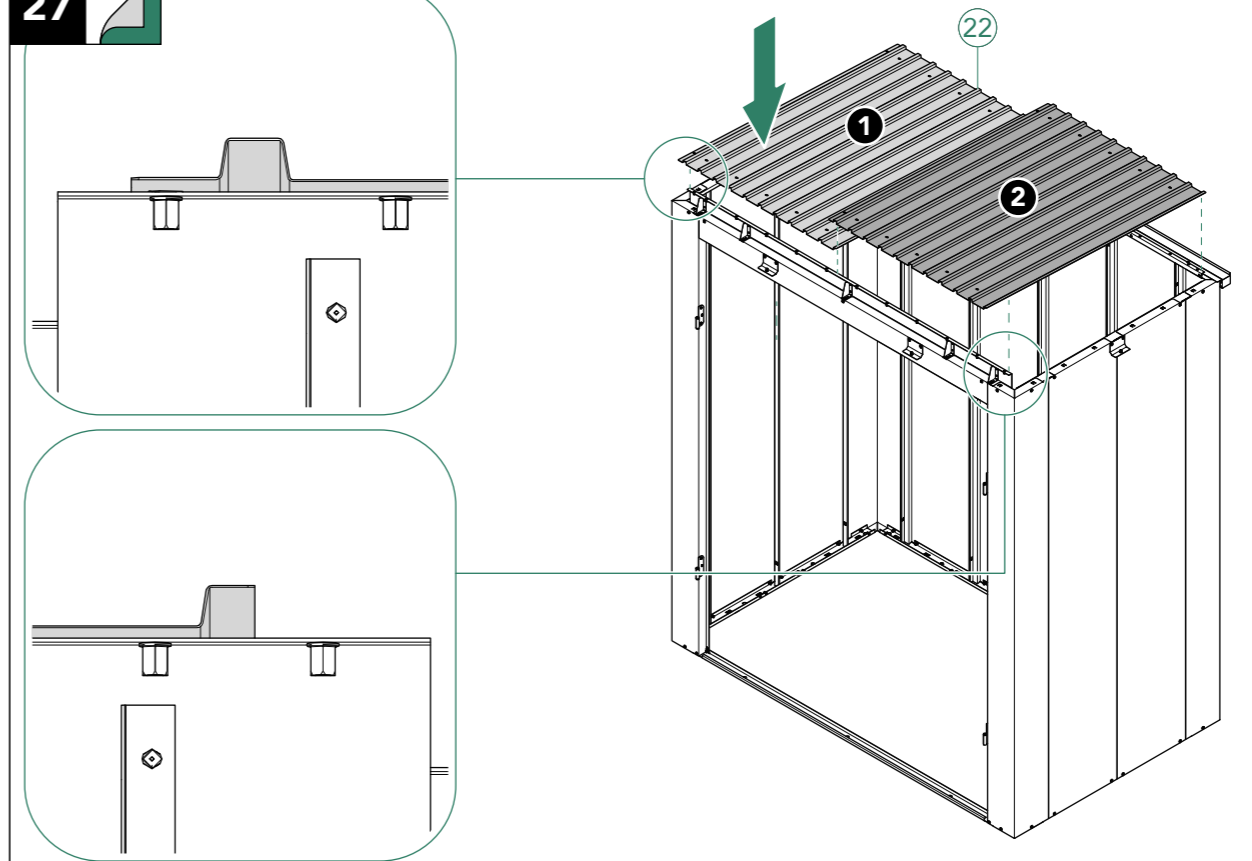

28

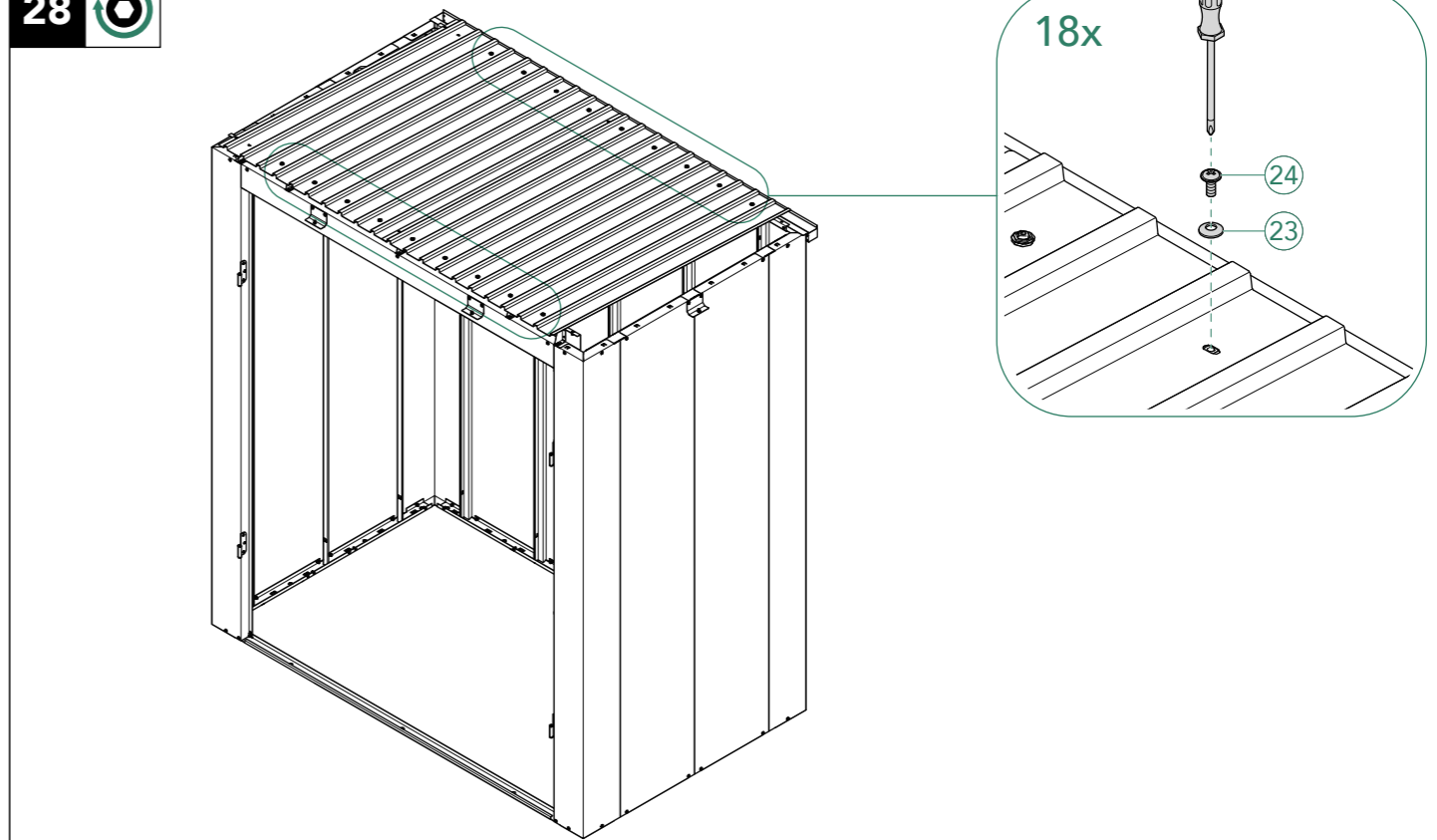

29

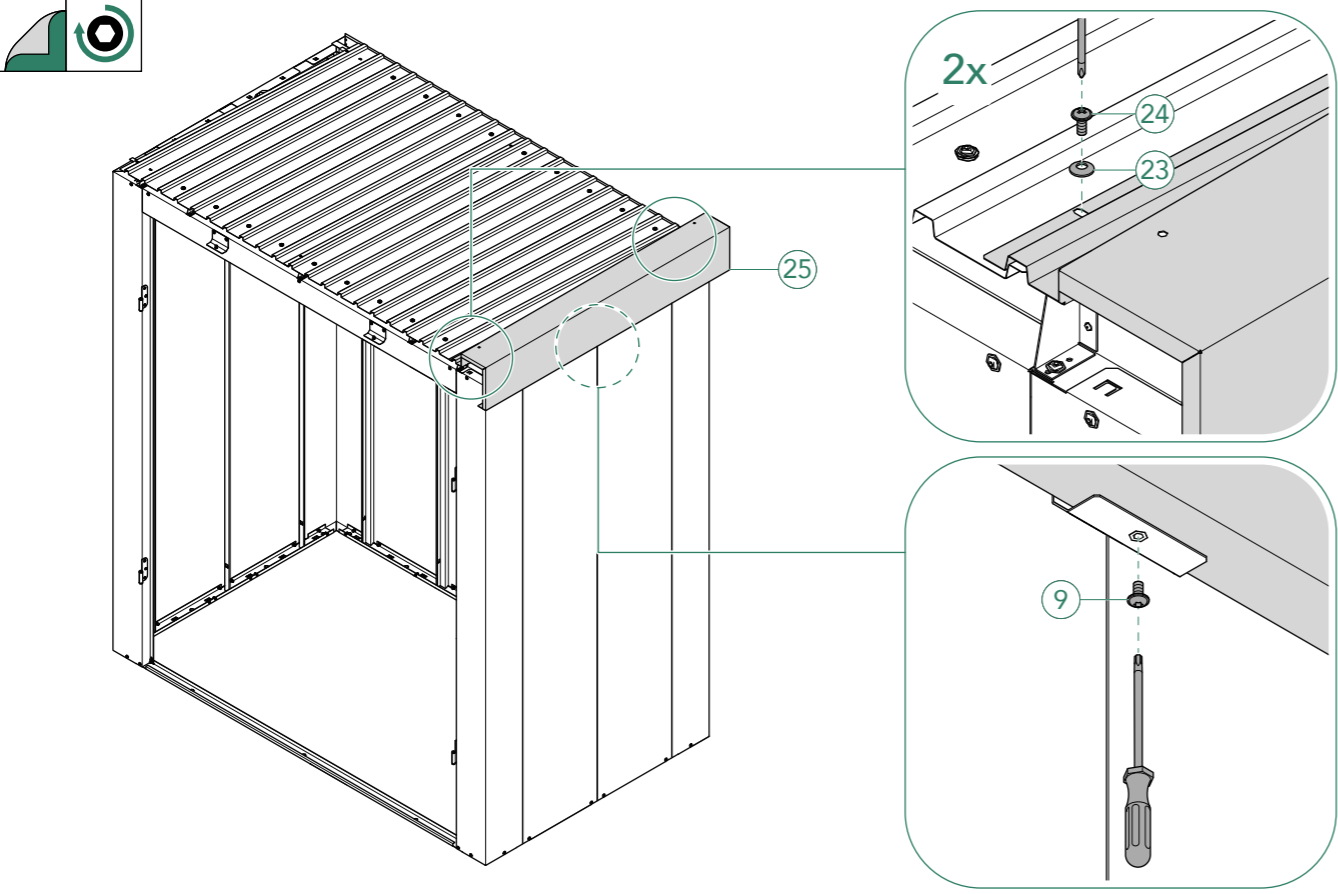

30

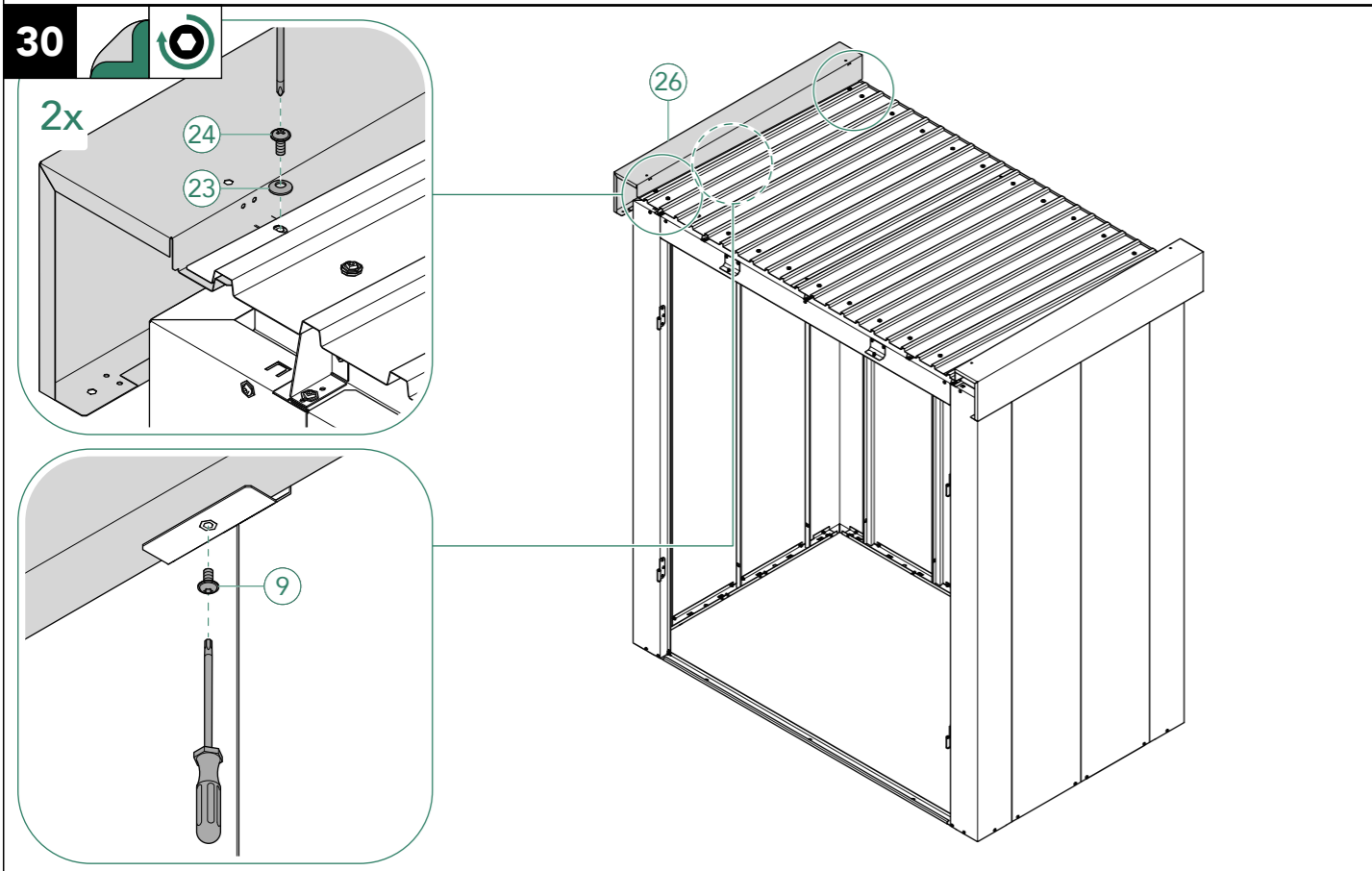

31

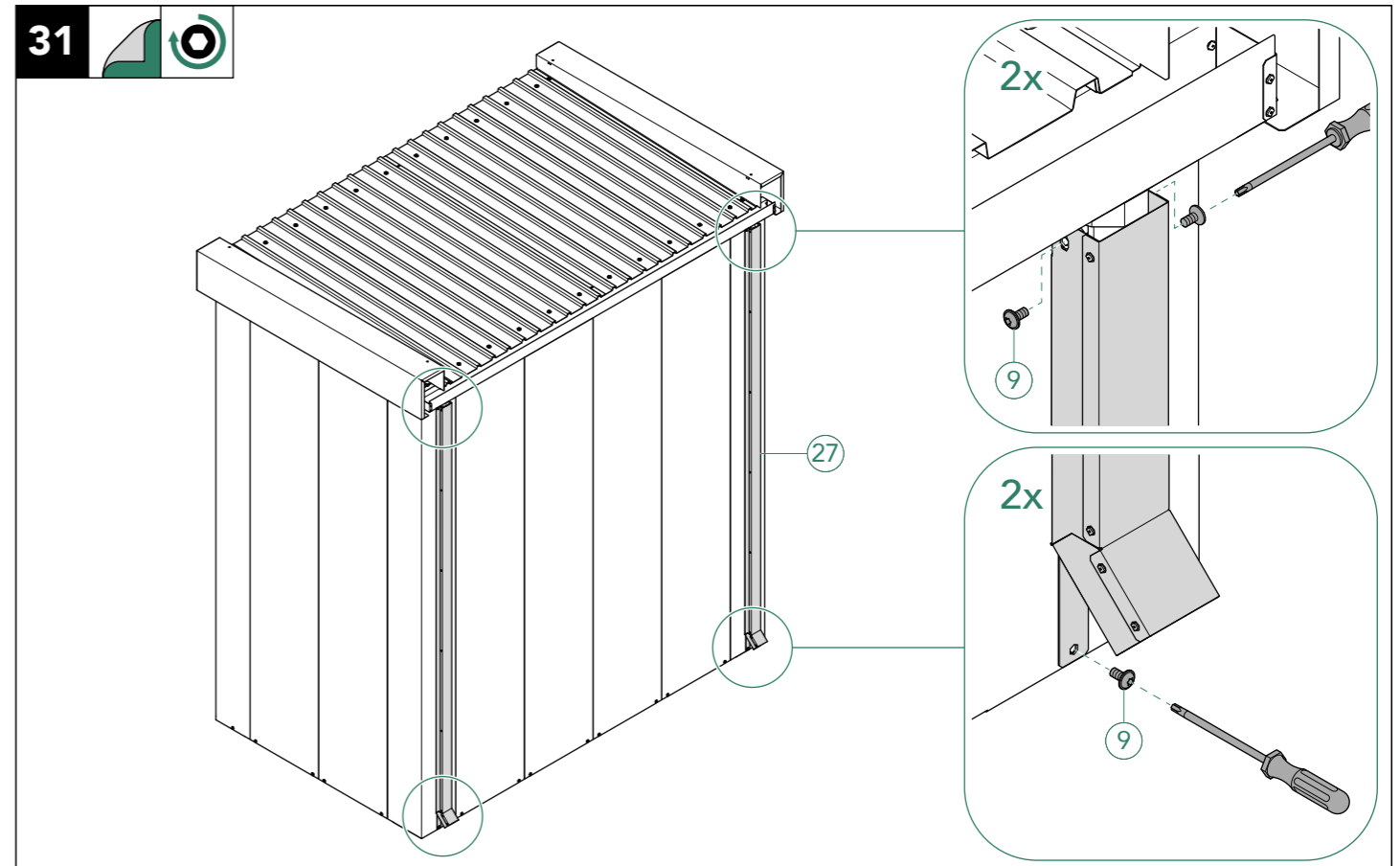

32

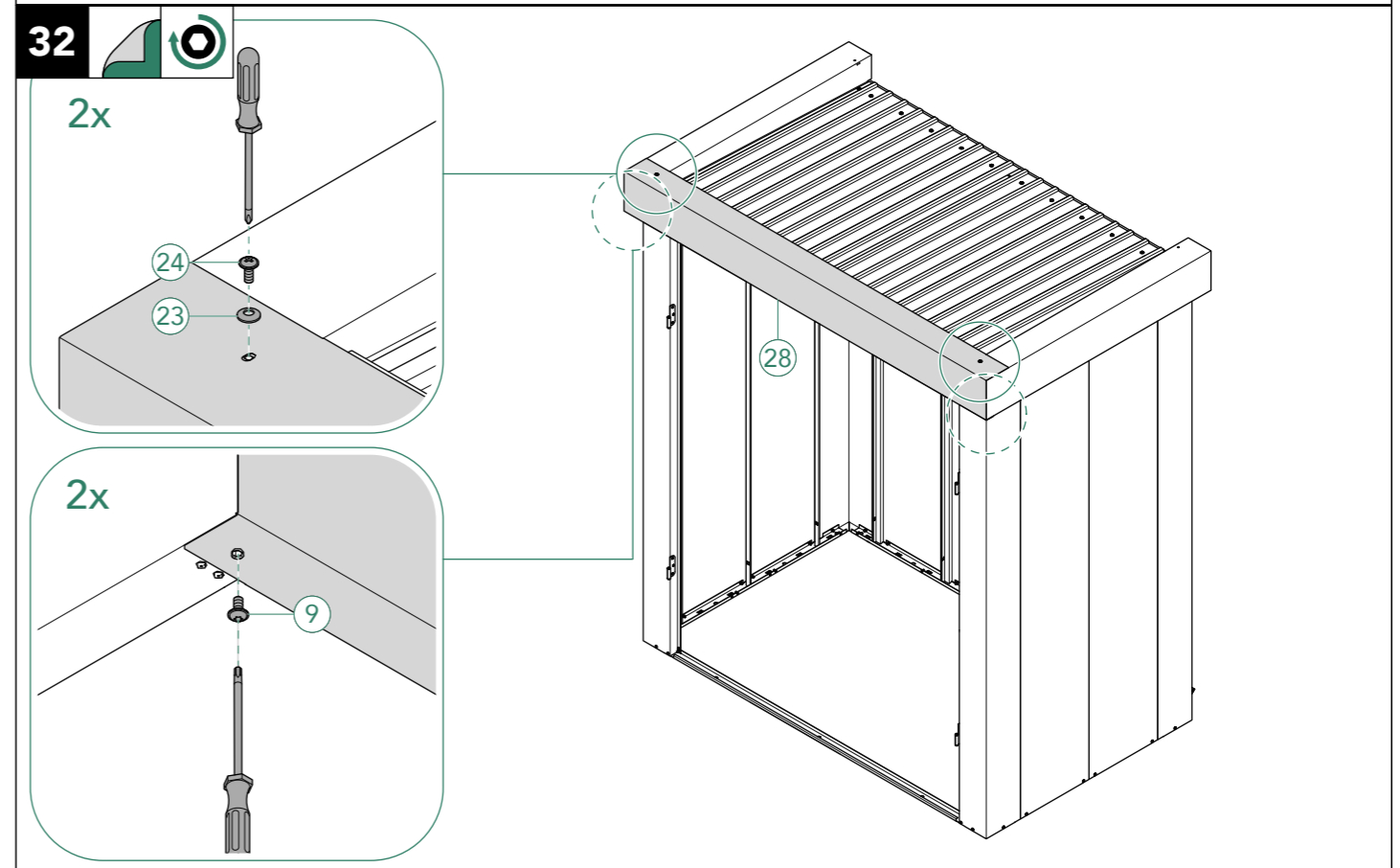

33

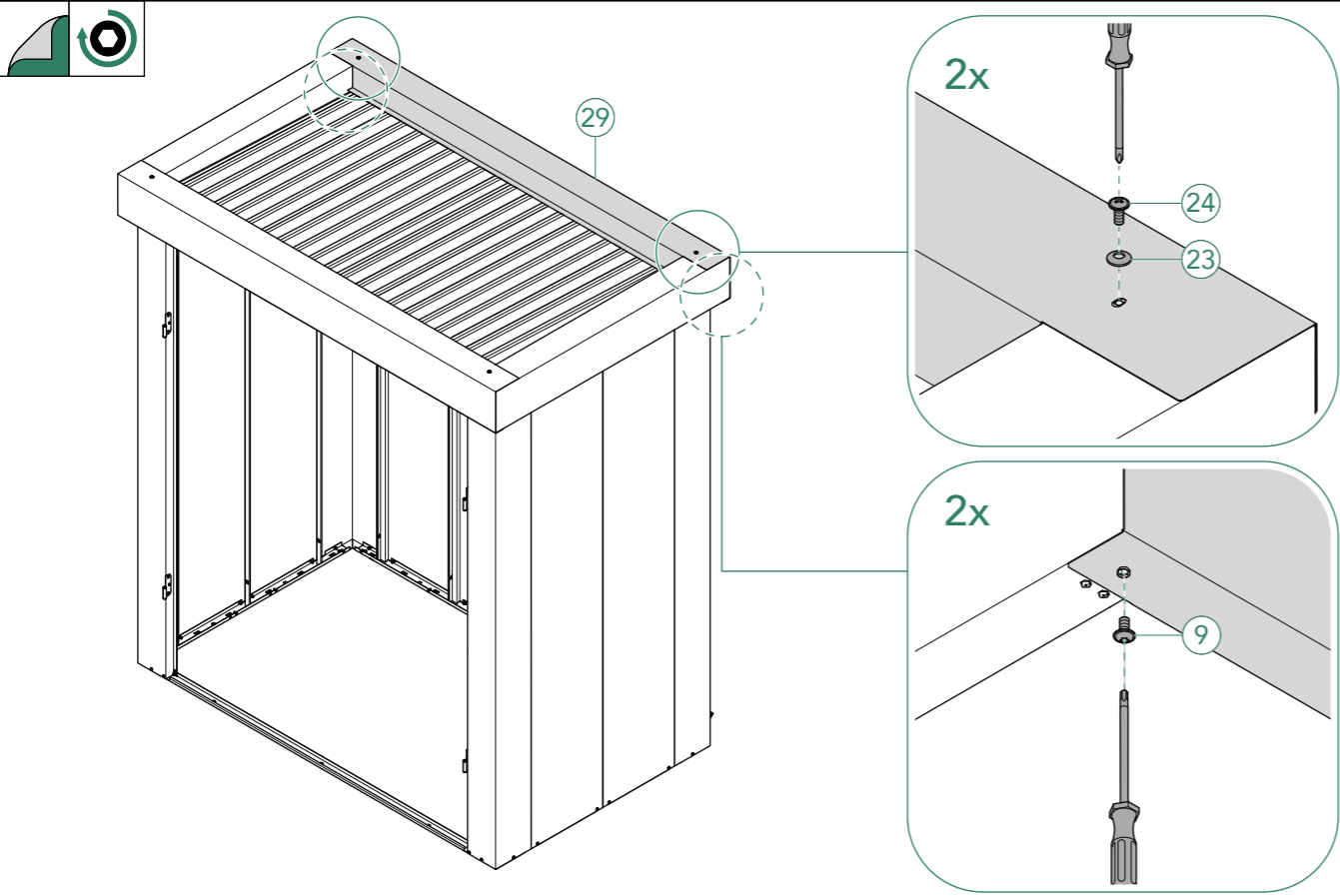

34

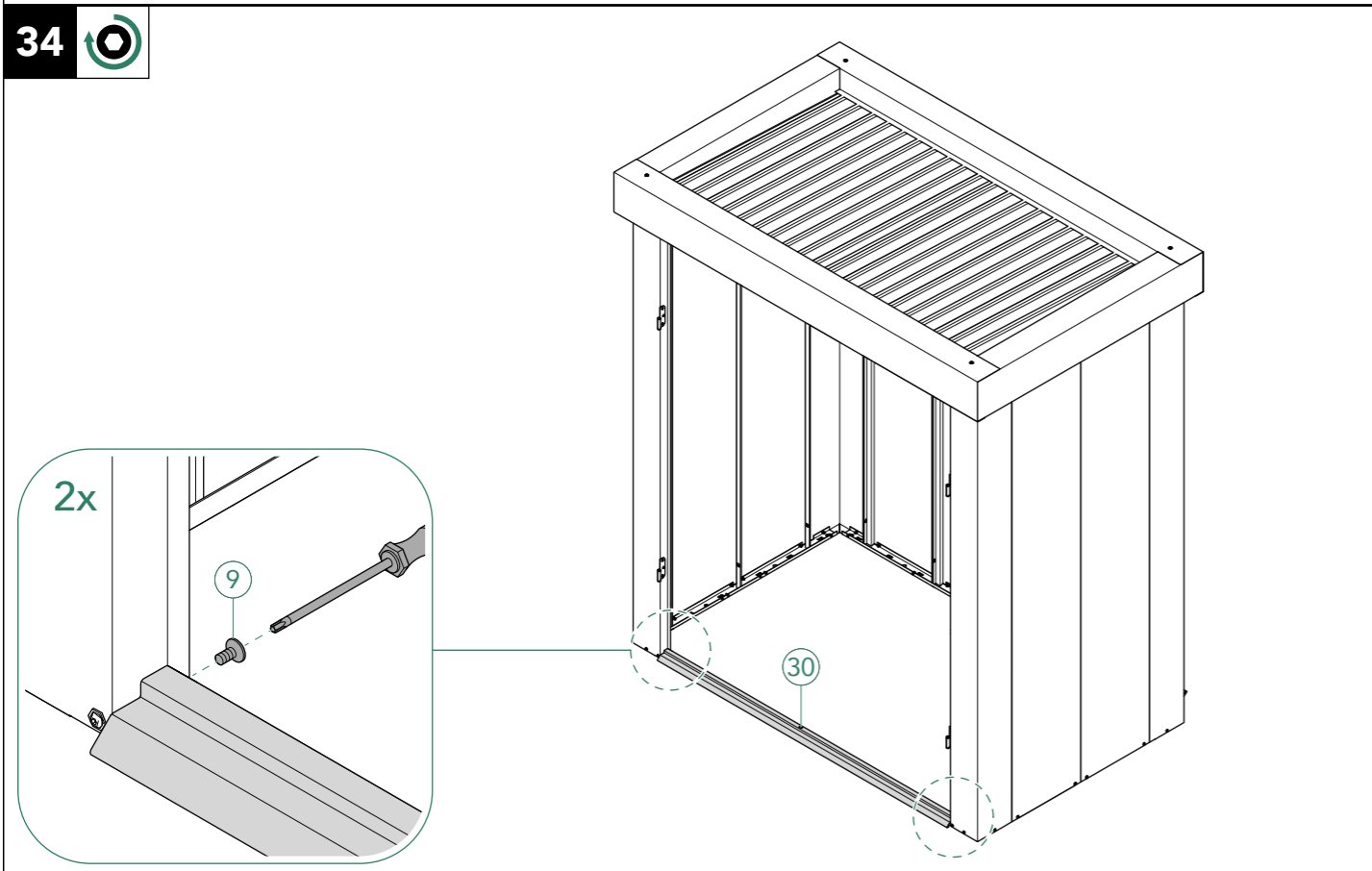

35

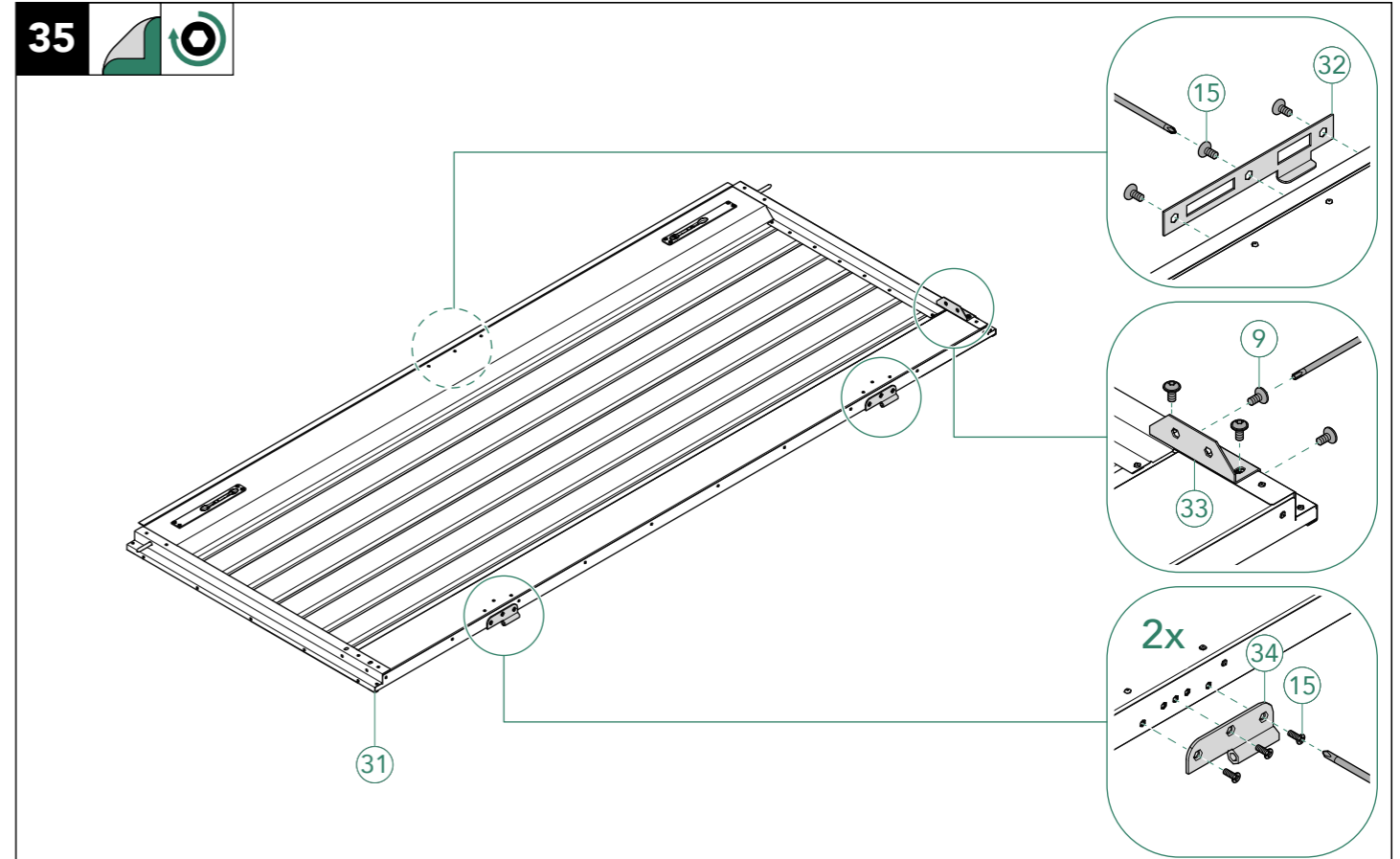

36

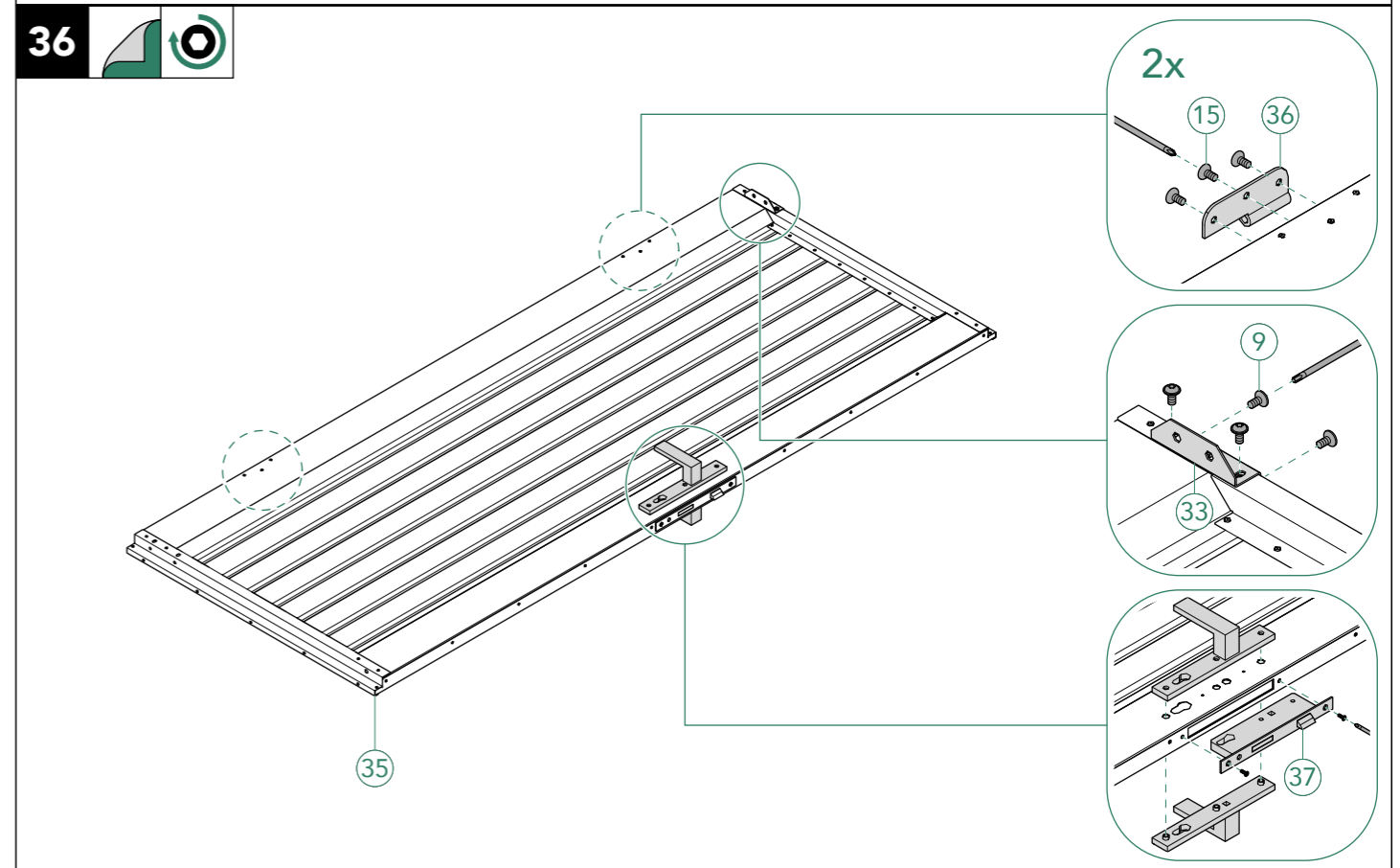

37

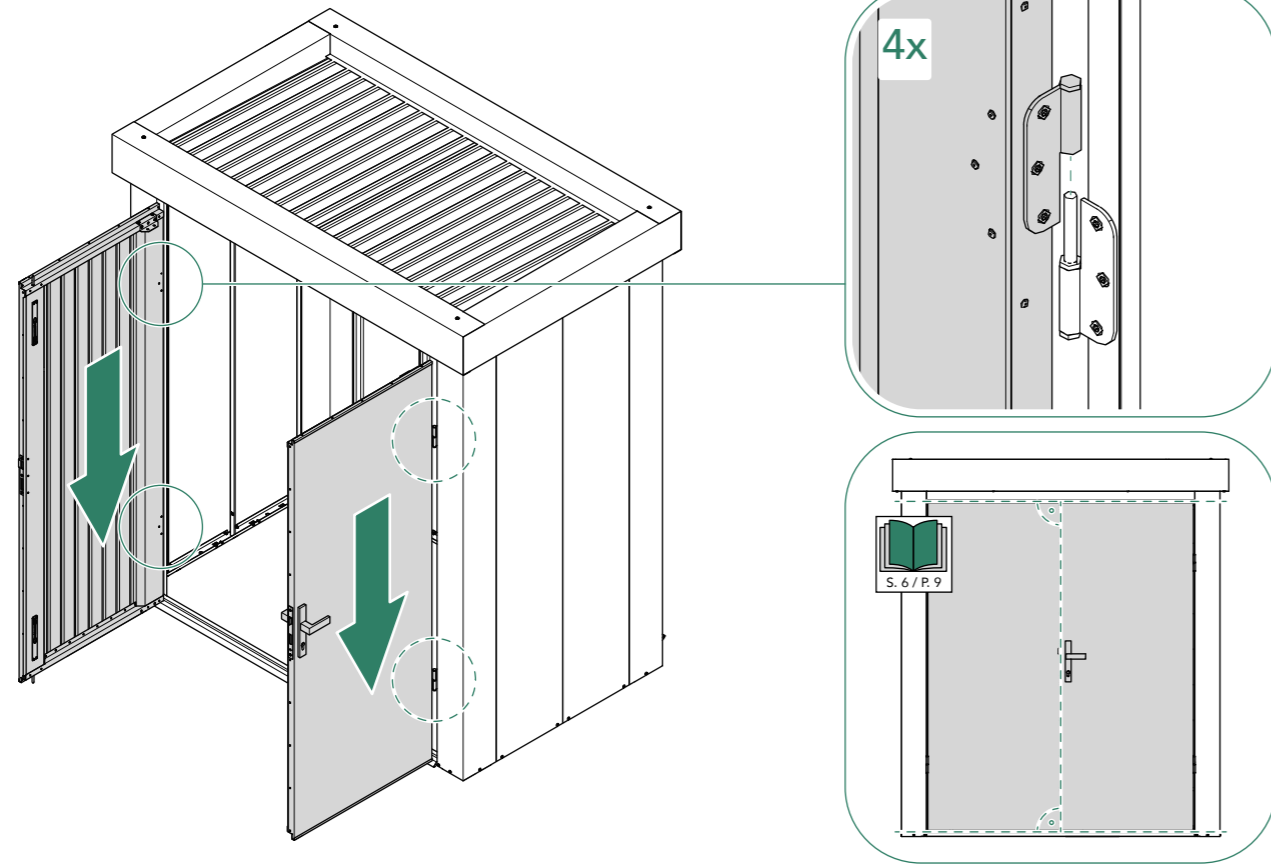

38

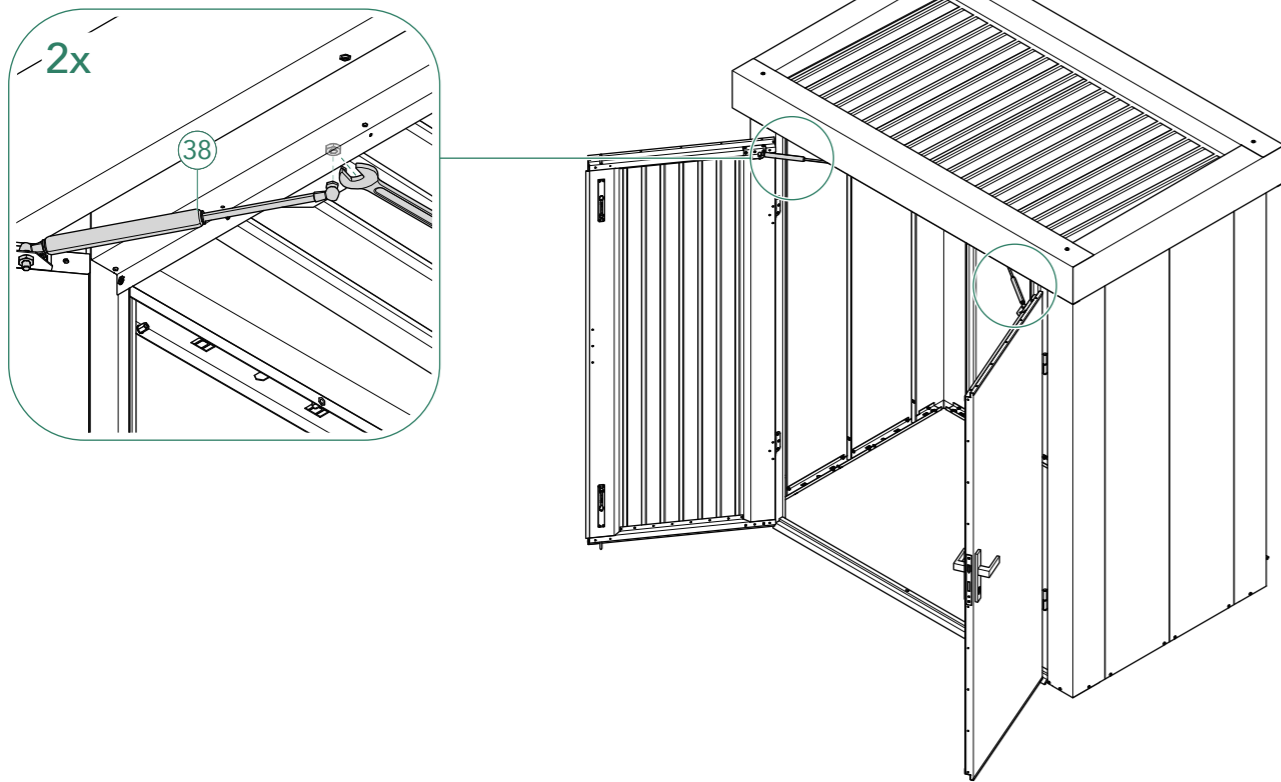

39

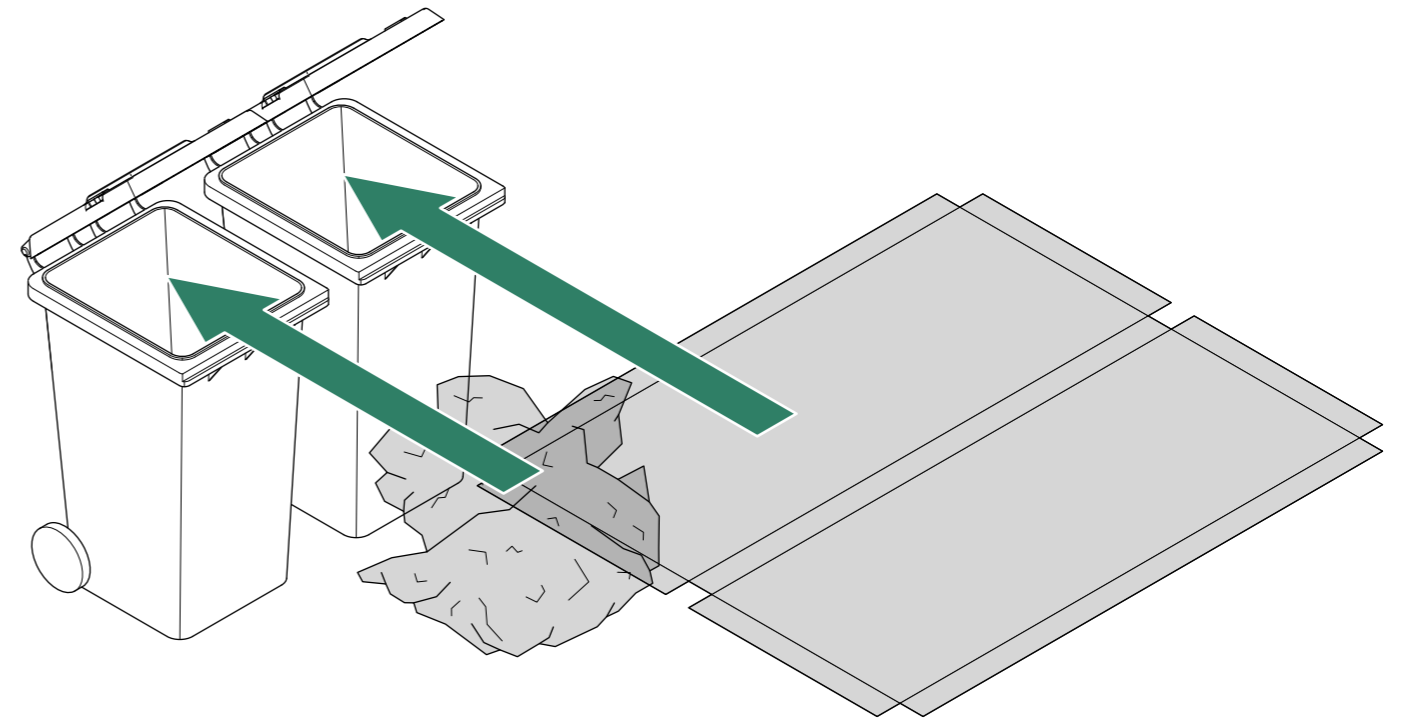

Zubehör (S/M/L):

- Bodenplatten
- altes bzw. neues Regalsystem
- Werkbank
- Langstielgut

DE

Danke für Ihr Vertrauen!

Sie sind mit unserem Produkt zufrieden? Die ersten neidischen Blicke wurden gesammelt? Dann würden wir uns über eine Bewertung auf unserer Website, Facebook oder Instagram freuen!

www.guardi.at

www.facebook.com/GUARDIGmbH

www.instagram.com/GUARDIAustria

Wir sind stets bemüht, unsere Produkte und unseren Service für Sie zu verbessern.

Benötigen Sie weitere Hilfe oder Unterstützung beim Aufbau, helfen wir Ihnen gern. Bitte schreiben Sie uns ein E-Mail an shop@guardi.at

EN

Thank you for trusting us!

Happy with our product? Caught the neighbours sneaking an envious glance or two?

We'd love you to leave a review on our website, Facebook or Instagram!

www.guardi.at

www.facebook.com/GUARDIGmbH

www.instagram.com/GUARDIAustria

We are constantly working to improve our products and service for you.

If you require further help or support with assembly, we will be happy to help. Please send us an email at shop@guardi.at



shop@guardi.at

www.guardi.at

+49 (0) 180 7000 777
+43 (0) 5 05 890